

Airtools

PRODUCT RANGE
TOKU, YOKOTA, RED ROOSTER, ACTION & SMC

www.rami-yokota.com



Impact wrenches
Impulse wrenches
Ratchet wrenches
Impact sockets
Screwdrivers
Drills
Grinders & sanders
Hammers
Needlescalers
Saws
Pumps
Air chain hoists
Spring balancers
Air treatment equipment

TiD-extra
Industrial Technologies d.o.o.

Contents



- 6 Assembly tools
- 7 Impact wrenches
- 13 Battery impact wrenches
- 14 System wrenches
- 15 Impulse wrenches
- 16 Impact sockets
- 26 Ratchet wrenches
- 27 Srewdrivers
- 33 Drills
- 35 Dowell pin pullers
- 36 Grinders
- 43 Sanders
- 46 Hammers
- 49 Breakers & rock drills
- 50 Chisels & drills
- 59 Needle scalers
- 60 Power cutters
- 62 Saws
- 65 RR Air Chain Hoists
- 69 Special tools
- 71 Various tools
- 75 Accessories for air tools
- 79 Air treatment equipment
- 88 Index

Brands



Impact sockets for professionals!

Action impact sockets are manufactured from the best materials: chrom-molybdenum alloy steel. Action impact sockets are made according to DIN 3121 and DIN 3129. The exact fitting causes less play between square drive and impact socket, an impact wrench and bolt. This results in longer life of the tool and impact socket.



SMC for optimal quality of the air

If the pressure is too low the tool will show less performance and less precision, resulting in slow starting and less productivity. 1 Bar pressure reduction means 25 % power loss.

Brands



Yokota Industrial air tools are manufactured to the highest quality

The tools have been developed for continuous use and are used in various industries. The Yokota grinders are produced with patented gears with little play. This is why vibration and wear are minimal. On page 4 you can find our brochure for our special Impuls tools.



Our Toku program contains a large range of industrial tools

Each tool is manufactured for long continuous use. The ball-bearings, gears and the air motor are produced with highest accuracy, smallest tolerances and therefore offer the best performance.



Red Rooster is our private label

This selection of tools from various manufacturers, gathered in one brand, completes our program. Red Rooster Industrial (RRI) contains high quality tools selected from the product range of the best manufacturers and our Automotive programma (RRA) covers the automotive market.



Air chain hoists

Red Rooster air chain hoists are of high industrial quality made by Toku. On page 4 you can find our special brochure for the Red Rooster Air Chain Hoists which are available from 0,125 up to 100 tonnes.

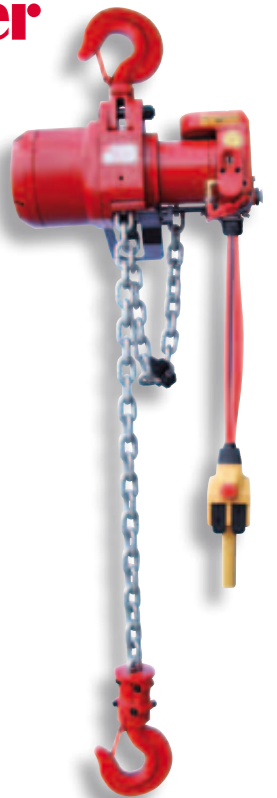



Yokota brochure

High Speed Production + High Quality Tightening

Available in the following languages:
English, French, German

Content:
Impulse wrenches, System wrenches, E-wrenches, (Non-) shut-off models, Double chamber air motor, Poka Yoke+, Battery tools.



Red Rooster Impulse Wrenches

Professional tools for faster assembly

Available in the following languages:
English, French, German

Content:
Shut off Models & Non Shut-off Models, Sleeve drive sockets, Accessories

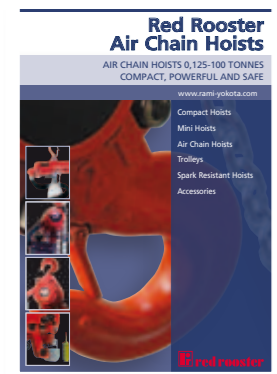

Red Rooster Air Chain Hoists

Air Chain Hoists 125 kg - 100 tonnes

Available in the following languages:
English, French, German, Polish

Content:
Air Chain Hoists 0,125 /100 tonnes, Compact hoists, Mini hoists, Air chain hoists, Trolleys, Explosion proof, Accessories

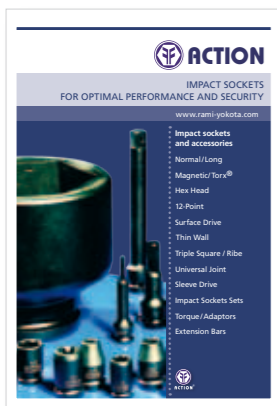

Action brochure

Impact sockets for optimal performance and security

Available in the following languages:
English, French, German

Content:
Normal/Long, Magnetic/Torx®, Hex Head/12-Point, Surface Drive/Thin wall, Universal joints, Sleeve drive, Impact Socket Sets, Torque/Adaptors, Extension Bars

➔➔➔➔ For recent versions go to: www.rami-yokota.com/printed-matter/brochures

How to use

Please take the following points into consideration before using new air tool(s). We advise you to oil your tool with resin and acid free oil through the air inlet. Check, before connecting the hose to the tool, whether the hose and quick coupler are clean.

Make sure that the air is dry and clean. We advise you to use air treatment equipment and a correctly adjusted lubricator. Use the correct oil (Red Rooster ATLUB air tool oil). For a good lubrication we advise use of a hose between oiler and airtool of max. 8 m. (26 ft.). If you want to use a longer hose, it is possible to mount a SMC jet-oiler. The jet oiler has a reach of approx. 200 m. The air pressure of the tool has to be 0.63 MPa. The correct hose diameter is necessary to achieve the best performance.

Pressure is too low!

If the pressure is too low the tool will show less performance and less precision, resulting in slow starting and less productivity. 1 Bar pressure reduction means 25% power loss!

Low pressure may occur if:

- The capacity of the compressor is insufficient,
- The air piping has been pitched incorrectly,
- There are air leaks,
- The air treatment equipment is not functioning properly and/or is not pitched correctly,
- The wrong size hose nipples or quick couplers are used,
- The tank is too small.

Maintenance

Draw water from the air piping and compressor tank daily. Check if the lubricators are filled with Red Rooster ATLUB air tool oil.

Please note

When using impact wrenches and impulse wrenches, the torques shown will vary if used on a soft joint, e.g. washers, gaskets, etc.

Quality of the air

Poor air quality can result in expensive production downtime, and will increase the time and costs of maintenance and will shorten the life of your tools.

Good quality air should be a first consideration, cost will earn itself back easily, as it will save your tools from damage.

Poor air quality can be caused by:

- Lack of necessary air treatment equipment
- Poor quality and/or wrong installation of the air treatment equipment
- Lack of maintenance of the air treatment equipment
- Incorrect hose diameter

Warranty

Warranty covers material and/or construction faults of the manufacturer, which are clearly definable. Replacement of parts or repair by an official Yokota/Toku/Red Rooster service workshop is free of charge when the tool is covered by warranty. Freight or postage is for the account of the customer. Damage attributed to normal wear, overloading or incorrect use is excluded from warranty.

Replacement of tools as a consequence of warranty claims is not part of the warranty arrangements. Also claims for loss of production and/or other damages are excluded from this warranty. Repairs under warranty can only be considered, when the tool is in its original state and it is accompanied by the purchase invoice.

Warranty claims have to be made through the distributor, who has supplied the tool concerned. We reserve the right to make unannounced changes to our tools. These warranty conditions are based on an 8 hour working day.

The warranty period from the date of purchase is as follows:

- 12 months** Yokota, Red Rooster and Toku industrial air tools
- 12 months** Red Rooster hoists and winches
- 12 months** Red Rooster automotive air tools
- 3 months** On repairs and replaced spare parts, which are repaired by either us or our official service workshops.

Guideline values for tightening torques

DIN 267*		3.6	4.6	4.8	5.8	8.8	10.9	12.9
Bolt	Socket size	Torque Nm	Torque Nm	Torque Nm	Torque Nm	Torque Nm	Torque Nm	Torque Nm
M1.6	-	0,05	0,065	0,086	0,11	0,17	0,24	0,29
M2	-	0,10	0,13	0,17	0,22	0,35	0,49	0,58
M2.2	-	0,13	0,017	0,23	0,29	0,46	0,64	0,77
M2.5	-	0,20	0,26	0,35	0,44	0,70	0,98	1,20
M3	-	0,35	0,46	0,61	0,77	1,20	1,70	2,10
M3.5	-	0,55	0,73	0,97	1,20	1,90	2,70	3,30
M4	7	0,85	1,1	1,5	1,9	2,9	4,1	4,9
M5	9	1,7	2,2	3,0	3,7	6	8,5	10
M6	10	2,9	3,9	5,1	6,4	10	14	17
M8	13	7	9,3	12	16	25	35	41
M10	17	14	19	25	31	49	69	83
M12	19	24	32	43	54	86	120	145
M14	22	39	51	68	86	135	190	230
M16	24	59	79	105	130	210	295	355
M18	27	81	110	145	180	290	405	485
M20	30	115	155	205	255	410	580	690
M22	32	155	205	275	345	550	780	930
M24	36	265	200	350	440	710	1000	1200
M27	41	295	390	520	650	1050	1500	1800
M30	46	395	530	710	880	1450	2000	2400
M33	50	540	720	960	1200	1900	2700	3250
M36	55	690	920	1250	1550	2450	3450	4150
M39	60	920	1200	1600	2000	3200	4500	5400
M42	65	1100	1500	1950	2450	3950	5550	6650
M45	70	1400	1850	2450	3100	4950	6950	8350
M48	75	1700	2250	3000	3750	5950	8400	10100
M52	80	2150	2900	3850	4800	7650	10800	12900
M56	85	2700	3600	4800	5950	9550	13400	16100
M60	90	3350	4450	5950	7400	11900	16700	20000
M64	95	4000	5350	7150	8950	14300	20100	24100
M68	100	4850	6500	8650	10800	17300	24300	29100

* These torque values are only guide lines and are calculated with friction factor 0,125.

Applications

Nuts and bolts can get stuck due to corrosion etc. Fortunately the impact wrench can untighten any joint without problems and without any major effort from the operator. To the observer, the most common impact wrench used in garages are ½" square drive, and are suitable for nuts and bolts upto M14 – M16. On the other hand, if there is a lot of work to do repairing vans and larger vehicles, then you will come across bolt sizes of M22 -M24 and a ¾" square drive should be used. The 1" square drive impact wrenches are usually used mainly in truck and bus workshops. Besides (car)workshops, impact wrenches are also used in other industries for example on shipyards, at construction workshops and in the petrochemical industry.

The right choice!

Most makes of impact wrenches look more or less the same. However the prices may differ. This is because of the quality of the impact mechanism. If the tool is only to be used once in a while, then it is advisable that you buy a cheaper model, if however the tool is going to be used more frequently then the industrial models are to be considered. Manufactured with stronger materials and better quality impact mechanisms, they guarantee a longer, more durable and trouble free lifetime. Cheaper tools are mostly executed with the single hammer impact mechanism. The industrial ones however, have a pin-clutch (Dynamact) or twin hammer system. Noise, vibration and weight also influence the price. An

industrial wrench has a better silencer and less vibration. In tyre workshops where impact wrenches are used continuously, these are the most important factors. Fortunately more and more impact wrenches are executed with a rear exhaust (outgoing airflow through the hand grip), while most of the conventional wrenches have an exhaust which is situated at the front of the tool. This can cause brake dust to be blown into the face of the operator while untightening the wheel nuts. Very uncomfortable.

Torque

Often people think that the torque of an impact wrench is about the same as the performance of the tool. However it is incorrect to compare impact wrenches on torque figures alone, as there is no standard for setting the torque. The specified torque is depending on various points: impact mechanism, weight, air consumption, quality.

Caution when tightening!

Impact wrenches were designed for untighten fixed joints. In practice they are also often used for the tightening nuts and bolts, but beware! Impact wrenches are, for example, a killer of soft joints. Because of the speed of the tool, the required torque will have been hit and over tightened very quickly. This could have serious consequences when it comes to the legal product liability regulations and the ISO certification. The tightening of nuts and bolts should be done by torque adjustable tools (see our impulse wrenches).

For improved safety on the road:
the first impact wrench with pre-adjusted shut-off torque



TOKU MI-590TR

The Toku MI-590TR has been developed to reduce the risks associated with over tightening wheel nuts within the Fleet management sector. The MI-590TR has an innovative shut off system that allows the wrench to be set to a required torque (450-700Nm), with full power and no shut off in reverse couple, this with the Dynamact hammer system that offers high speed wheel removal, controlled tightening along with vastly reduced vibration levels. The tool that is essential for truck tire service.

Impact wrenches

Mechanisms

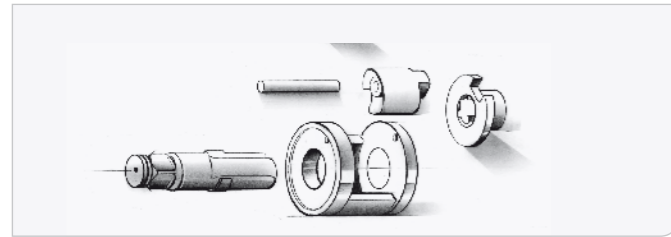

The **1-hammer system** makes 1 impact per rotation at 1 side of the anvil. This causes a higher energy per blow. The impact wrenches with the 1-hammer system are especially suitable for disassembly jobs.

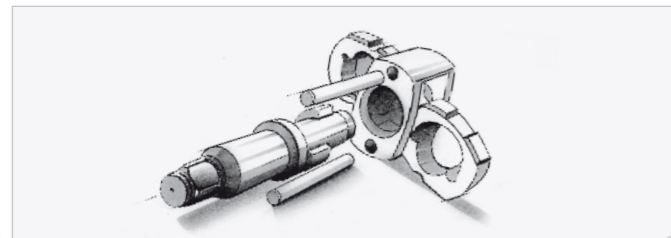

The **twin-hammer system** makes 2 impacts per rotation at both sides of the anvil. Same principal as the 2-hammer system, manufactured differently.



The **closed hammer system**. this construction, without loose hammerpin, will prevent breakage. The working principle is based on the 1-hammer system.

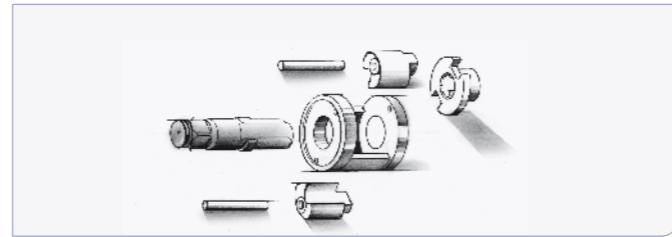

The **2-hammer system** makes 2 impacts per rotation at both sides of the anvil.

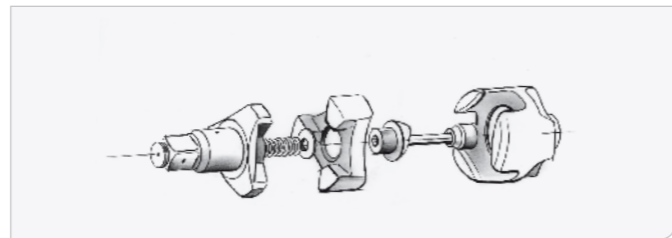

The **3-jaw system** gives, per rotation, one impact on all 3 jaws of the anvil. This gives a high torque output. Impact wrenches with the 3-jaw system are only suitable for hard joints.

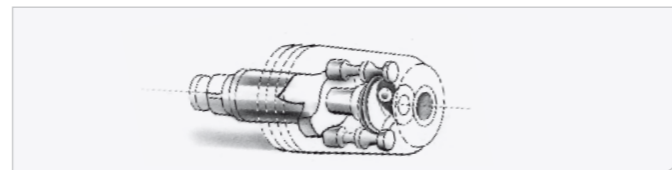

The **Dynapact impact system** has two pins hammering on the anvil, making 1 impact per rotation at both sides of the anvil at the same time. This system give high torque output and is well balanced.

Air consumption

To choose the right compressor one needs to know how much air l/min a tool uses and how the tool will be used, continuously or intermittently. There are 2 ways to estimate the air consumption of air tools:

Method 1: Measure air consumption with continuous operation

Method 2: Measure with intermittent operation

Continuous operation

The total consumption when the trigger is pulled for a period of one minute (this is what you will find in this catalogue). If you use our tool like this you need a compressor with the capacity stated.

Intermittent operation

The air consumption is measured when the trigger is pulled

Impact wrenches

Pistol models



Type	Brand	Square drive	Type ⁴⁾	Bolt capacity mm	Impact-mechanism	RPM	Torque Nm	Power adjustment ⁵⁾	Air cons. l/s	Weight kg	Inlet-thread	Hose-diameter mm	Vibration m/s ²	Noise level dB(A)
YW-6CL ¹⁾	YOKOTA	3/8"	H	6	1-Hammer	6.500	145	-	4,2	1,6	PT 1/4"	6,5	18	81
MI-12	TOKU	3/8"	R	12	Twin-Hammer	9.500	160	R/L 4 levels	5,3	1,2	PT 1/4"	6,5	9,9	82
MI-16 3/8	TOKU	3/8"	R	12	Twin-Hammer	6.200	270	R/L 4 levels	5,3	1,5	PT 1/4"	6,5	4,6	87
RRI-16N 3/8	RRI	3/8"	R	12	Twin-Hammer	11.000	340	R 3 levels	5	1,3	PT 1/4"	6,5	4,6	83
MI-16 1/2	TOKU	1/2"	R	12	Twin-Hammer	6.200	310	R/L 4 levels	5,3	1,5	PT 1/4"	6,5	4,6	87
RRI-16N 1/2	RRI	1/2"	R	14	Twin-Hammer	11.000	405	R 3 levels	5	1,2	PT 1/4"	6,5	4,6	83
RR-15P	RRA	1/2"	R	14	1-Hammer	6.900	430	R/L 4 levels	6,6	2,4	PT 1/4"	10	11	82
RRI-18N	RRI	1/2"	R	16	Twin-Hammer	7.000	815	R 3 levels	8,2	2	PT 1/4"	10	4,8	83
RRI-18NT ²⁾	RRI	1/2"	R	16	Twin-Hammer	7.000	815	90 Nm ²⁾	8,2	2	PT 1/4"	10	3,1	83
RR-160H	RRA	1/2"	R	16	Dynapact	8.000	580	R/L 4 levels	8	2,3	PT 1/4"	10	11	82
V-160P	YOKOTA	1/2"	R	16	1-Hammer	6.500	580	R/L 4 levels	7,5	2,8	PT 1/4"	10	13	84
MI-1600R	TOKU	1/2"	R	16	Closed hammer	7.000	520	R/L 4 levels	8,3	2,6	PT 1/4"	10	9	80
MI-17HEG	TOKU	1/2"	R	16	Twin-Hammer	5.500	650	R/L 4 levels	8,3	2,4	PT 1/4"	10	7,4	88
RRI-21 ³⁾	RRI	1/2"	R	20	Twin-Hammer	7.500	900	R 3 levels	9,2	2	PT 1/4"	10	3,4	86
MI-20P	TOKU	3/4"	R+H	24	Twin-Hammer	5.000	1.000	R/L 4 levels	9,6	3,9	PT 3/8"	10	4,6	92
RR-20PN	RRA	3/4"	R+H	20	1-Hammer	4.800	720	R/L 4 levels	9,2	4,6	PT 1/4"	10	4	87
RRI-24N	RRI	3/4"	R+H	24	Twin-Hammer	5.500	1.625	R 3 levels	9,1	3,4	PT 3/8"	10	4,8	90
RRI-24N 1	RRI	1"	R+H	24	Twin-Hammer	5.500	1.900	R 3 levels	9,1	3,7	PT 3/8"	10	4,8	90
RRI-27P	RRI	1"	R+H	27	Twin-Hammer	6.000	2.250	R/L 3levels	15	6,3	PT 1/2"	13	8,8	96
RRI-36P	RRI	1"	R+H	36	Twin-Hammer	5.000	2.700	R/L 4 levels	24	9,9	PT 1/2"	13	8,6	100
MI-3800PR	TOKU	1"	R+H	36	Closed hammer	4.500	2.100	R/L 4 levels	15	9,3	PT 1/2"	13	8	84
MI-3800PLR ⁴⁾	TOKU	1"	R+H	36	Closed hammer	4.500	2.000	R/L 4 levels	15	9,9	PT 1/2"	13	8	84

¹⁾ YW-6CL has an angled head for working in confined spaces

²⁾ RRI-18NT: maximum tightening torque: 90 Nm, full power in untightening

³⁾ RRI-21: breakloose torque 1.750 Nm

⁴⁾ L = Long anvil

⁵⁾ Type: R = Ring type / H = Hole type / R + H = Ring + Hole type

Impact wrenches

Heavy Duty - models

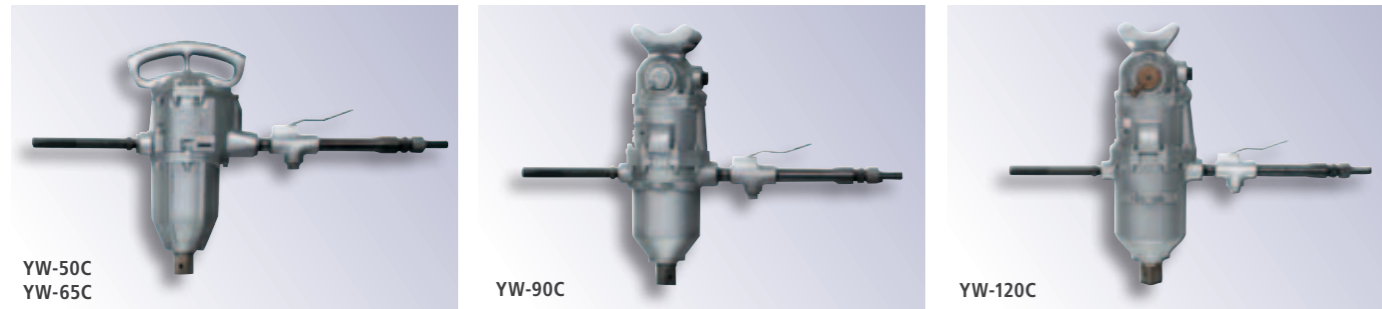

Type	Brand	Square drive	Type ¹⁾	Bolt capacity mm	Impact-mechanism	RPM	Torque Nm	Air cons. l/s	Weight kg	Inlet-thread	Hose-diameter mm	Vibration m/s ²	Noise level dB(A)
YW-50C YW-65C	YOKOTA	1½"	H	52	2-Hammer	3.000	4.500	30,0	27,0	PT 1"	19	2,3	90
YW-90C ²⁾	YOKOTA	1¾"	H	90	2-Hammer	1.700	16.500	41,0	62,0	PT 1"	19	2,3	94
YW-120C	YOKOTA	2½"	H	130	2-Hammer	1.800	33.000	68,0	115,0	PT 1"	25	5	93

¹⁾ Type: H = Hole type / ²⁾ 1½" square drive on request / The air consumption of the impact wrenches has been measured under working conditions.

Impact wrenches

Straight models



Type	Brand	Square drive	Type ¹⁾	Bolt capacity mm	Impact-mechanism	RPM	Torque Nm	Power adjustment	Air cons. l/s ³⁾	Weight kg	Inlet-thread	Hose-diameter mm	Vibration m/s ²	Noise level dB(A)
RRI-36E	RRI	1"	R+H	36	Twin-Hammer	5.000	2.700	R/L 4 levels	24	11	PT 1/2"	13	8,6	102
MI-38ESR	TOKU	1"	R+H	36	Twin-Hammer	3.700	1.850	R/L 4 levels	11,7	7,75	PT 1/2"	13	8,7	93
MI-38ELR	TOKU	1"	R+H	36	Twin-Hammer	3.700	1.800	R/L 4 levels	11,7	7,95	PT 1/2"	13	8,7	93
MI-590TR ²⁾	TOKU	1"	R+H	36	Dynapact	3.800	1.850	450-700 Nm	11,7	10,9	PT 1/2"	13	9,1	93
MI-3800ESR	TOKU	1"	R+H	36	Closed hammer	4.500	2.100	R/L 4 levels	15,0	9,3	PT 1/2"	13	8	84
MI-3800ELR	TOKU	1"	R+H	36	Closed hammer	4.500	2.000	R/L 4 levels	15,0	9,9	PT 1/2"	13	8	84
MI-42ESR	TOKU	1"	R+H	42	Twin-Hammer	3.900	2.850	R/L 4 levels	23,0	9,4	PT 1/2"	13	7,6	99
MI-42ELR	TOKU	1"	R+H	42	Twin-Hammer	3.900	2.800	R/L 4 levels	23,0	10,6	PT 1/2"	13	7,6	99
MI-4500ESR	TOKU	1"	R+H	45	Closed hammer	3.700	2.900	R/L 4 levels	23,0	13,4	PT 1/2"	13	7	84
MI-4500ELR	TOKU	1"	R+H	45	Closed hammer	3.700	2.900	R/L 4 levels	23,0	14,5	PT 1/2"	13	7	84
MI-5500ES	TOKU	1½"	H	52	Dynapact	2.800	5.500	R/L 4 levels	15,0	18,1	PT 1/2"	13	14,3	109
RRI-1060	RRI	1½"	H	52	3-Jaw	3.000	4.500	-	27,0	16,0	PT 1/2"	19	5	97

¹⁾ Type: H = Hole type, R + H = Ring + Hole Type / L = Long spindle / ²⁾ Impact wrench with shut-off in forward (450-700 Nm) / ³⁾ Airconsumption of impact wrenches is measured under load

Impact wrenches sets

RRI-18N/SETSTD



RRI-18N/SETSTD including:

- impact wrench RRI-18
- 5 x 1/2" impact sockets (SW 17-19-21-24-27)
- 1 x extension bar 100 mm
- blow mold case

MI-17HE/SETSTD



MI-17HE/SETSTD including:

- impact wrench MI-17HEG
- 5 x 1/2" impact sockets (SW 17-19-21-24-27)
- 1 x extension bar 100 mm
- blow mold case

RRI-18N/SETLNG



RRI-18N/SETLNG including:

- impact wrench RRI-18
- 5 x 1/2" impact sockets (SW 17-19-21-24-27 Deep)
- 1 x extension bar 100 mm
- blow mold case

MI-17HE/SETLNG



MI-17HE/SETLNG including:

- impact wrench MI-17HEG
- 5 x 1/2" impact sockets (SW 17-19-21-24-27 Deep)
- 1 x extension bar 100 mm
- blow mold case

Bolt Cleaner Set MBC-30S



Bolt Cleaner Set MBC-30S contents:

- One handheld airtool, 1800 rpm with 1/4" Hex chuck
- Four boltcleanercups with inner wirebrush, for M20, M24 and M30 bolts
- Three hole brushes, for M20, M24 and M30 nuts and holes
- One hole buff

TYPE

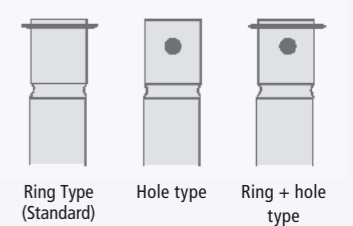



DIMENSIONS

Type	A mm	A* mm	B mm	C mm	D mm
MI-12	150	-	24	-	-
MI-16	170	-	27	-	-
MI-17HEG	178	-	31	-	-
MI-20P	215	-	38	-	-
MI-38ESR	337	-	50	-	-
MI-38ELR	-	515	50	-	-
MI-42ESR	370	-	60	-	-
MI-42ELR	-	517	60	-	-
MI-590TR	570	50	-	-	-
MI-1600 (R)	180	-	33	-	-
MI-1600 L(R)	-	224	33	-	-
MI-3800PR	281	-	55	-	-
MI-3800PLR	-	430	55	-	-
MI-3800ESR	355	-	55	-	-
MI-3800ELR	-	504	55	-	-
MI-4500ESR	460	-	60	-	-
MI-4500ELR	-	584	60	-	-
MI-5500ES	553	-	63	-	-
RR-15P	180	-	30	-	-
RR-20PN	239	-	38	-	-
RR-160H	185	-	30	-	-
RRI-1060	400	-	78	-	-
RRI-16N	150	-	30	-	-
RRI-18N	185	-	30	-	-
RRI-18NT	185	-	30	-	-
RRI-21	190	-	35	-	-
RRI-24N	210	-	50	-	-
RRI-27P	210	-	41	-	-
RRI-36P	230	-	67	-	-
RRI-36E	-	520	58	-	-
V-160P	182	-	34	-	-
YW-6CL	215	-	14	50	63
YW-50C	535	-	355	448	160
YW-65C	606	-	344	434	162
YW-90C	674	-	358	448	186
YW-120C	827	-	527	461	226

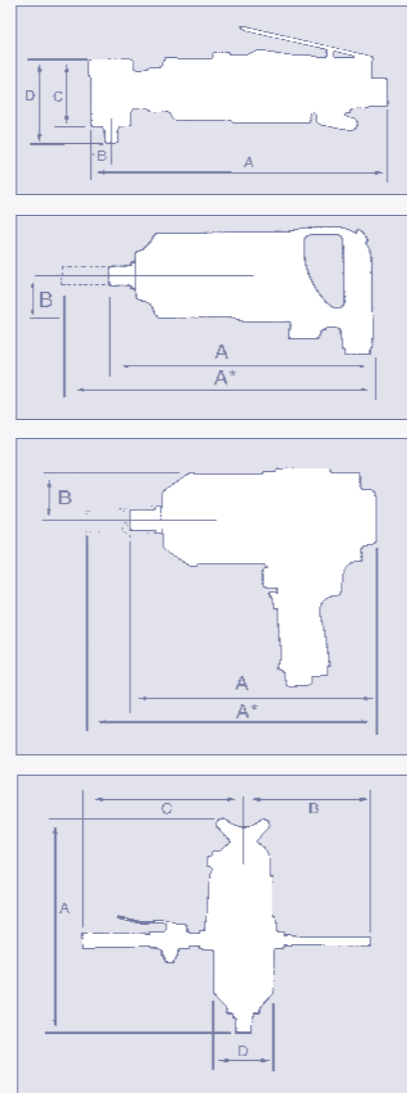

SPARE PARTS

Spring rings for impact sockets

Type	Spring ring	O-Ring
TOKU 3/8"	13-08-03-092	9010-1004-00-00
TOKU 1/2"	13-08-03-106	13-11-17-108
TOKU 3/4"	13-08-03-113	9010-1012-00-00
TOKU 1"	13-08-03-144	13-11-05-013
V-160P	0208-0416-00-00	13-11-05-006
RR-15P	40303	13-11-05-006
RR-20PN	280-016	9010-1012-00-00
RRI-16N/18N(T)	40303	13-11-05-006
RRI-21	250-033	00-4103
RRI-24N	45-405112	OR01000305
RR-160H	250-033	00-4103

ACCESSORIES



Rubber protection cover

Order number	For type
AH0001020	MI-17HEG
AH0001030	MI-20P



Exhaust Hose Assembly

Order number	For type
EH-454033P	RRI-16/18/18T
EH-454051P	RRI-24

RRI-BI serie



Red Rooster now introduces two new cordless impact wrenches. Convenient shape for good handling. The impact wrenches are developed for assembly- and disassembly applications.

Main areas of use: construction industry, workshop and agricultural industry.

These impact wrenches are delivered in blow molded case, including tool, two batteries and a quick-charger.

Characteristics:

- Sliding battery
- Power bar on the battery shows charge left
- Aggressive Dynapact clutch
- LED lamp illuminating the working area of the bolt head
- Safe working by means of the carrying strap
- Single push button for direction
- Stepless trigger
- Quick charger (1 hour)



RRI-BI217E



RRI-BI474E

Type	Brand	Drive	Bolt capacity mm	RPM	Torque Nm	Weight kg	Battery voltage (Volt)	Battery type Li-ion (Ah)
RRI-BI217E SET	RRI	3/8"	10	2.300	217	1,95	14,4	3
RRI-BI474E SET	RRI	1/2"	16	1.800	474	3	19,2	3

System wrenches

Poka Yoke+ System* (Torque levels 6 to 490 Nm)

Superior clampforces

Conventional shut-off impulse tools are shutting-off at point 2 in the graph. This is too early for a optimum joint quality because of the always occurring relaxation. The Poka Yoke+ controller controls the shut-off at point 3 in the curve, a number impulses after achieving the torque. By these extra impulses the relaxation is minimized with optimum clamp force and torque accuracy. The torque is adjusted at the impulse mechanism, in combination with the parameters set in the controller YTC 3 controls an accurate and reliable shut-off.

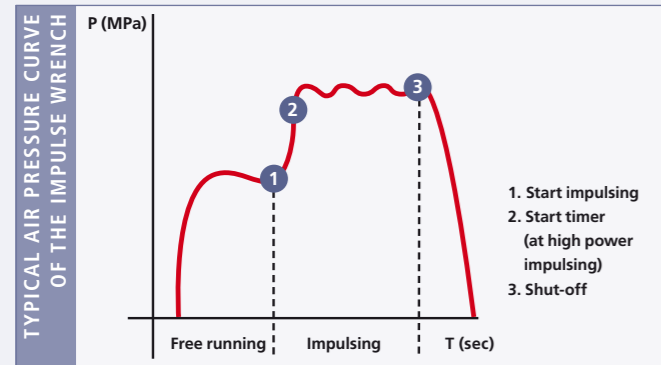

Controller YTC-3

- Power supply: 100 - 240V AC
- Input: 8
- Relay output: 4 (opening and shutting capacity: Max. DC-48W, AC-220VA)
- Output for solenoid valve: 1 (DC24V 2W)



System features

- Group control
- Controlled shut-off
- Double tightening detection
- Interlock with assembly line
- Error judgement on trigger release
- Teach-in mode for programming
- Oil deterioration indication

* The whole system is more accurate than shut-off or standard impulse wrenches..

System wrenches (Torque 4 to 600 Nm)



Controller YETC-210/300

Yokota has impulse wrenches with an integrated transducer (system wrenches). In combination with a controller YETC-210 / YETC-300 the torque can be set and judged. The measured torque can be stored in a computer or printed. With this system can be shown that the correct joint was made, in case of product liability claims. The systems wrenches only need 1 to 2 seconds for each joint. The tools have no kick back and fit perfectly in a Poka Yoke assembly area.



Optional on TKa System Wrenches: integrated LED status-signal:

- Green = OK
- Red = not OK

Visible from every angle: left, right, from top and behind.



The transducer for the YEX, YED and TKa

The strain gauges are positioned on the main shaft, picking up the twisting torque on the main shaft at each impulse as close as possible to the socket. The electric signals are transmitted by induction through the internal- and external coils. Due to this principle the Yokota transducer is very reliable, accurate and without wear.

This catalogue only presents a small part of our System wrenches. The separate catalogue Yokota Hi-tec is available on demand, and shows a big variety of different options (see page 4).

Impulse wrenches

Hi-Tec series (up to max. 600 Nm)

Type

- Impulse wrenches
- System wrenches
- Poka Yoke+ system
- (Non) shut off tools
- Cordless impulse wrenches

Characteristics impulse wrenches

- Extremely low weight and good for use with non-lubricated air.
- Light, powerful, small and they have no kick-back.
- Double chamber air motor.
- Have proven themselves worldwide in the leading car- and general assembly industry, tightening threaded fasteners.



Non shut-off impulse wrench

Type	Square / Hex drive	Bolt capacity mm	RPM	Torque Nm*	Air consumption l/sec	Weight kg	Inlet-thread	Hose diameter mm	Dimensions A mm	Dimensions B mm	Vibration m/s ²	Noise-level dB(A)
YLa70A	1/4" Hex	6 - 8	7.000	20 - 28	5,5	0,8	PT 1/4"	6,5	132	22	1,4	74
YLa80A	1/4" Hex	8	7.000	24 - 35	5,8	0,9	PT 1/4"	6,5	139	22	1,2	75
YLa70E	3/8" Square	6 - 8	7.000	20 - 35	5,5	0,8	PT 1/4"	6,5	132	22	1,4	74
YLa80E	3/8" Square	8	7.000	33 - 50	5,8	0,9	PT 1/4"	6,5	139	22	1,2	75
YLa90E	3/8" Square	8 - 10	6.500	47 - 70	6,7	1,0	PT 1/4"	10	148	24	1,2	78
YLa110E	1/2" Square	10 - 12	6.000	65 - 105	9,6	1,4	PT 1/4"	10	164	26	1,8	81
YLa120E	1/2" Square	12	6.600	80 - 130	10	1,8	PT 1/4"	10	172	28	2,2	82
YLa140E	1/2" Square	14	6.000	100 - 160	13	2,2	PT 1/4"	10	190	30	2,4	84

* Note: Torque values are to be used as guidance only.

Shut-off impulse wrench

Type	Square / Hex drive	Bolt capacity mm	RPM	Torque Nm*	Air consumption l/sec	Weight kg	Inlet-thread	Hose diameter mm	Dimensions A mm	Dimensions B mm	Vibration m/s ²	Noise-level dB(A)
YLT50A	1/4" Hex	5	4.300	4,5 - 8	4,2	0,95	PT 1/4"	6,5	164	22,5	1,1	70
YLT60A	1/4" Hex	6	5.300	6,0 - 13,0	5,5	0,95	PT 1/4"	6,5	164	22,5	1,4	72
YLT70A	1/4" Hex	6-8	6.800	13,0 - 28,0	6,0	1,01	PT 1/4"	6,5	177	23	1,8	74
YLT50E	3/8" Square	5	4.300	4,5 - 8	4,2	0,95	PT 1/4"	6,5	164	22,5	1,1	72
YLT60E	3/8" Square	6	5.300	7,0 - 15,5	5,5	0,95	PT 1/4"	6,5	164	22,5	1,4	72
YLT70E	3/8" Square	6-8	6.800	15,0 - 32,0	6,0	1,01	PT 1/4"	6,5	177	23	1,8	74
YLT80E	3/8" Square	8	6.800	30,0 - 55,0	7,3	1,12	PT 1/4"	10	187	24,5	1,9	78
YLT110E	1/2" Square	10-12	5.800	50 - 85	8,3	1,51	PT 1/4"	10	194	28,5	1,8	81
YLT120E	1/2" Square	12	5.400	70 - 115	8,6	1,79	PT 1/4"	10	201	31	2,2	83
YLT140E	1/2" Square	14	5.200	110 - 150	11,8	2,08	PT 1/4"	10	214	32,5	5,2	85
YLT150	3/4" Square	16	4.400	140 - 210	11,8	2,95	PT 1/4"	10	237	38,5	6,2	85

* Note: Torque values are to be used as guidance only.

FEATURES

- **Maximum accuracy**
Extreme accurate and fast. Repeatability by new principle: shut-off valve and reset.
- **Maximum durability**
Check valve mechanism reduces load on the O-ring inside the oil pulse mechanism.
- **Maximum ergonomics**
Ergo touch / Ergo grip / Ergo trigger
- **Maximum environment**
Reduction of CO2 emission / Low noise / Low vibration

This catalogue only presents a small part of our Impulse wrenches. The separate catalogue Yokota is available on demand, and shows a big variety of different options (see page 4).

Impact sockets

1/4"

SIZE											
6-Point normal					1	deep					2
Type	A/F mm	DRWG	D1 mm	D2 mm	L mm	L2 mm	Type	L mm	L2 mm		
Metrical											
DO0014-0-004	4	A	7,6	13	23	4	DO0014-1-004	50	4		
DO0014-0-0045	4,5	A	8,2	13	23	5	DO0014-1-045	50	6		
DO0014-0-005	5	A	8,8	13	23	5	DO0014-1-005	50	6		
DO0014-0-0055	5,5	A	9,5	13	23	5	DO0014-1-0055	50	7		
DO0014-0-006	6	A	10	13	23	6	DO0014-1-006	50	7		
DO0014-0-007	7	A	11,3	13	23	6	DO0014-1-007	50	7		
DO0014-0-008	8	A	12,5	13	23	7	DO0014-1-008	50	9		
DO0014-0-009	9	A	13,8	13	23	7	DO0014-1-009	50	9		
DO0014-0-010	10	C	15	13	23	7	DO0014-1-010	50	9		
DO0014-0-011	11	C	16,3	13	23	8	DO0014-1-011	50	9		
DO0014-0-012	12	C	17	13	23	8	DO0014-1-012	50	9		
DO0014-0-013	13	C	18,8	13	23	8	DO0014-1-013	50	9		
DO0014-0-014	14	C	20	13	23	8	DO0014-1-014	50	9		
DO0014-0-015	15	C	21	13	23	8	DO0014-1-015	50	9		

SIZE											
6-Point normal					3	deep					4
Type	A/F mm	DRWG	D1 mm	D2 mm	L mm	L2 mm	Type	L mm	L2 mm		
Metrical											
DO6050P050	5	A	8,8	13	23	3	DO6050R050	50	3		
DO6050P055	5,5	A	9,5	13	23	3	DO6050R055	50	3		
DO6050P060	6	A	10	13	23	3	DO6050R060	50	3		
DO6050P070	7	A	11,3	13	23	3	DO6050R070	50	3		
DO6050P080	8	A	12,5	13	23	3	DO6050R080	50	3		
DO6050P090	9	C	13,8	13	23	4	DO6050R090	50	4		
DO6050P100	10	C	15	13	23	4	DO6050R100	50	4		
DO6050P110	11	C	16,3	13	23	5	DO6050R110	50	5		
DO6050P120	12	C	17	13	23	5	DO6050R120	50	5		
DO6050P130	13	C	18,8	13	23	5	DO6050R130	50	5		
DO6050P140	14	C	20	13	23	6	DO6050R140	50	6		
DO6050P150	15	C	21	13	23	6	DO6050R150	50	6		

SIZE							
Torx® internal							5
Type	A/F mm	DRWG	D2 mm	L mm	L1 mm	-	
Metrical							
DO64701005	T5	F	13	35	2,0	-	
DO64701006	T6	F	13	35	2,0	-	
DO64701007	T7	F	13	35	2,0	-	
DO64701008	T8	F	13	35	2,0	-	
DO64701009	T9	F	13	35	2,0	-	
DO64701010	T10	F	13	35	2,8	-	
DO64701015	T15	F	13	35	2,8	-	
DO64701020	T20	F	13	35	2,8	-	
DO64701025	T25	F	13	35	3,0	-	
DO64701027	T27	F	13	35	3,0	-	
DO64701030	T30	F	13	35	3,8	-	

Torx® is a trademark of Textron.

3/8"

SIZE											
6-Point normal					6	deep					7
Type	A/F mm	DRWG	D1 mm	D2 mm	L mm	L2 mm	Type	L mm	L2 mm		
Metrical											
DO1038-0-006	6	A	11	19	30	4	DO1038-1-006	63	12		
DO1038-0-007	7	A	12,5	19	30	8	DO1038-1-007	63	12		
DO1038-0-008	8	A	14	19	30	8	DO1038-1-008	65	12		
DO1038-0-010	10	A	16	19	30	8	DO1038-1-010	65	12		
DO1038-0-012	12	B	19	19	30	9	DO1038-1-012	65	12		
DO1038-0-013	13	A	20	22	30	9	DO1038-1-013	65	25		
DO1038-0-014	14	A	21	22	30	9	DO1038-1-014	65	25		
DO1038-0-015	15	B	22	22	30	11	DO1038-1-015	65	25		
DO1038-0-016	16	C	24	22	30	11	DO1038-1-016	65	25		
DO1038-0-017	17	C	25	22	30	11	DO1038-1-017	65	25		
DO1038-0-019	19	C	27,5	22	30	11	DO1038-1-019	65	25		
DO1038-0-024	24	C	34	23	30	13	DO1038-1-024	65	25		

SIZE											
6-Point normal					3	deep					4
Type	A/F mm	DRWG	D1 mm	D2 mm	L mm	L2 mm	Type	L mm	L2 mm		
Metrical											
DO6051P006	6	A	11,5	19	30	3	DO6051R006	55	3		
DO6051P007	7	A	12,5	19	30	3	DO6051R007	55	3		
DO6051P008	8	A	14	19	30	3	DO6051R008	55	3		
DO6051P009	9	A	15	19	30	4	DO6051R009	55	4		
DO6051P010	10	A	16,5	19	30	4	DO6051R010	55	4		
DO6051P011	11	A	17,5	19	30	5	DO6051R011	55	5		
DO6051P012	12	B	19	19	30	5	DO6051R012	55	5		
DO6051P013	13	A	20	22	30	5	DO6051R013	55	5		
DO6051P014	14	A	21,5	22	30	6	DO6051R014	55	6		
DO6051P015	15	B	22	22	30	6	DO6051R015	55	6		
DO6051P016	16	C	24	22	30	6	DO6051R016	55	6		
DO6051P017	17	C	25	22	30	6	DO6051R017	55	6		
DO6051P018	18	C	26	22	30	7	DO6051R018	55	7		
DO6051P019	19	C	27,5	22	30	7	DO6051R019	55	7		

SIZE							
Hex Driver 6-Point (Inbus)							8
Type	A/F mm	DRWG	D2 mm	L mm	L1 mm	-	
Metrical							
DO696204A	4	F	19	50	16	-	
DO696205A	5	F	19	50	16	-	
DO696206A	6	F	19	50	16	-	
DO696208A	8	F	19	50	16	-	
DO696210A	10	F	19	50	16	-	
DO696212A	12	F	19	50	16	-	
DO696214A	14	F	19	50	16	-	

Other versions of impact sockets are available (magnetic, thinwalled, other sizes). Ask for our special socket-catalogue on page 4.

Impact sockets

3/8"

SIZE							
Torx® external							1
Type	A/F mm	DRWG	D1 mm	D2 mm	L mm	L2 mm	
Metrical							
DO63310005	E5	A	9	19	32	4,5	
DO63310006	E6	A	10	19	32	5	
DO63310008	E8	A	10,5	19	32	6	
DO63310010	E10	A	12,5	19	32	7,5	
DO63310012	E12	A	15	19	32	8,5	

SIZE							
Torx® internal							2
Type	A/F mm	DRWG	D1 mm	L mm	L1 mm	-	
Metrical							
DO64711015	T15	F	19	50	2,8	-	
DO64711020	T20	F	19	50	3,0	-	
DO64711025	T25	F	19	50	3,0	-	
DO64711030	T30	F	19	50	3,8	-	
DO64711040	T40	F	19	50	4,3	-	
DO64711045	T45	F	19	50	5,0	-	
DO64711050	T50	F	19	50	5,5	-	

SIZE											
12-Point normal					3	deep					4
Type	A/F mm	DRWG	D1 mm	D2 mm	L mm	L2 mm	Type	L mm	L2 mm		
Metrical											
DO65815006	6	A	11	19	30	5	DO65817006	63	5		
DO65815007	7	A	12	19	30	8	DO65817007	63	12		
DO65815008	8	A	13	19	30	8	DO65817008	63	12		
DO65815009	9	A	15	19	30	8	DO65817009	65	12		
DO65815010	10	A	16	19	30	8	DO65817010	65	22		
DO65815011	11	A	17,5	19	30	9	DO65817011	65	22		
DO65815012	12	A	18,5	19	30	9	DO65817012	65	22		
DO65815013	13	A	20	22	30	10	DO65817013	65	22		
DO65815014	14	A	21	22	30	11	DO65817014	65	22		
DO65815015	15	B	22	22	30	12	DO65817015	65	22		
DO65815016	16	C	24	22	30	12	DO65817016	65	24		
DO65815017	17	C	25	22	30	12	DO65817017	65	24		
DO65815018	18	C	26	22	30	13	DO65817018	65	24		
DO65815019	19	C	27	22	30	13	DO65817019	65	24		
DO65815020	20	C	28	22	30	13	DO65817020	65	24		
DO65815021	21	C	30	22	30	14	DO65817021	65	24		
DO65815022	22	C	31	23	30	15	DO65817022	65	24		
DO65815023	23	C	32	23	30	15	DO65817023	65	24		
DO65815024	24	C	34	23	30	16	DO65817024	65	24		
DO65815025	25	C	35	23	30	16	DO65817025	65	24		
DO65815026	26	C	36	23	30	16	DO65817026	65	24		

1/2"

SIZE											
6-Point normal					5	deep					6
Type	A/F mm	DRWG	D1 mm	D2 mm	L mm	L2 mm	Type	L mm	L2 mm		
Metrical											
DO2012-0-008	8	A	14,5	24	38	9	DO2012-1-008	78	13		
DO2012-0-009	9	A	16	24	38	12	DO2012-1-010	78	14		
DO2012-0-010	10	A	17	24	38	12	DO2012-1-011	78	14		
DO2012-0-012	12	A	20	24	38	12	DO2012-1-012	78	14		
DO2012-0-013	13	A	21	24	38	12	DO2012-1-013	78	14		
DO2012-0-014	14	A	22	24	38	12	DO2012-1-014	78	17		
DO2012-0-015	15	A	24	24	38	12	DO2012-1-015	78	17		
DO2012-0-016	16	A	25	26	38	12	DO2012-1-016	78	17		
DO2012-0-017	17	A	26	26	38	13	DO2012-1-017	78	17		
DO2012-0-018	18	A	27,5	28	38	13	DO2012-1-018	78	17		
DO2012-0-019	19	A	29	30	38	13	DO2012-1-019	78	19		
DO2012-0-021	21	B	32	32	38	13	DO2012-1-021	78	24		
DO2012-0-022	22	C	32	32	38	13	DO2012-1-022	78	24		
DO2012-0-024											

Impact sockets

1/2"

SIZE						
Torx® internal						
Type	A/F	DRWG	D2	L	L1	-
	mm		mm	mm	mm	
DO64721025	T25	F	25	55	3,0	-
DO64721030	T30	F	25	55	3,8	-
DO64721040	T40	F	25	55	3,8	-
DO64721045	T45	F	25	55	4,3	-
DO64721050	T50	F	25	55	5,0	-
DO64721055	T55	F	25	55	5,5	-
DO64721060	T60	F	25	55	8,0	-

SIZE						
Torx® external						
Type	A/F	DRWG	D1	D2	L	L2
	mm		mm	mm	mm	mm
Metrical						
DO63320010	E10	A	15	25	38	7,5
DO63320011	E11	A	15,5	25	38	8
DO63320012	E12	A	16	25	38	8,5
DO63320014	E14	A	18,5	25	38	10
DO63320016	E16	A	20	25	38	11
DO63320018	E18	A	22	25	38	12
DO63320020	E20	A	25	30	38	13,5
DO63320022	E22	A	26,5	30	45	18
DO63320024	E24	A	28,5	30	45	18

SIZE						
6-Point normal						
Type	A/F	DRWG	D1	D2	L	L2
	mm		mm	mm	mm	mm
Metrical						
DO6052P008	8	A	15	25	38	3
DO6052P009	9	A	16	25	38	4
DO6052P010	10	A	17,5	25	38	4
DO6052P011	11	A	18,5	25	38	5
DO6052P012	12	A	20	25	38	5
DO6052P013	13	A	21	25	38	5
DO6052P014	14	A	22,5	25	38	6
DO6052P015	15	A	23,7	30	38	6
DO6052P016	16	A	25	30	38	6
DO6052P017	17	A	26,5	30	38	6
DO6052P018	18	A	27,5	30	38	7
DO6052P019	19	A	29	30	38	7
DO6052P020	20	B	30	30	38	7
DO6052P021	21	C	31	30	38	8
DO6052P022	22	C	32,5	30	38	8
DO6052P024	24	C	35	30	45	10

SIZE						
12-Point normal						
Type	A/F	DRWG	D1	D2	L	L2
	mm		mm	mm	mm	mm
Metrical						
DO63825008	8	A	14	25	38	6
DO63825009	9	A	16	25	38	6
DO63825010	10	A	17,5	25	38	7
DO63825011	11	A	19	25	38	8
DO63825012	12	A	20	25	38	9
DO63825013	13	A	21	25	38	9
DO63825014	14	A	22,5	25	38	11
DO63825015	15	A	23,5	30	38	11
DO63825016	16	A	25	30	38	11
DO63825017	17	A	26,5	30	40	11
DO63825018	18	A	27,5	30	40	13
DO63825019	19	A	29	30	40	13
DO63825020	20	B	30	30	40	13
DO63825021	21	C	31	30	40	15
DO63825022	22	C	32,5	30	40	15
DO63825023	23	C	34	30	40	15
DO63825024	24	C	35	30	45	18
DO63825025	25	C	36	30	45	18
DO63825026	26	C	38	30	50	18
DO63825027	27	C	39	30	50	19
DO63825028	28	C	40	30	50	19
DO63825029	29	C	41	30	50	19
DO63825030	30	C	42,5	30	50	21
DO63825032	32	C	44	30	50	22
DO63825033	33	C	46,5	30	50	22
DO63825036	36	C	50,5	30	50	24

SIZE							
6-Point thin wall deep, with plastic stop and sleeve							
Type	A/F	DRWG	D1	D2	D3	L	L2
	mm		mm	mm	mm	mm	mm
Metrical							
DO61126015 (white)	15	H	22	30	25	85	13
DO61126017 (blue)	17	H	24	30	27	85	14
DO61126019 (yellow)	19	H	26	30	29	85	15
DO61126021 (red)	21	H	28	30	31	85	17
DO61126022 (green)	22	H	29,5	30	32,5	85	18

Thin wall sockets are not covered by the Action warranty.

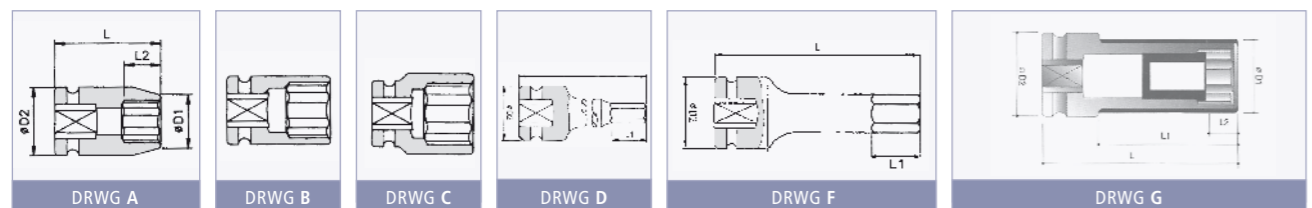

Impact sockets

3/4"

SIZE						
6-Point normal						
Type	A/F	DRWG	D1	D2	L	L2
	mm		mm	mm	mm	mm
Metrical						
DO3034-0-013	13	A	25	44	50	9
DO3034-0-017	17	A	31	44	50	12
DO3034-0-018	18	A	32	44	50	13
DO3034-0-019	19	A	33	44	50	13
DO3034-0-021	21	A	36	44	50	15
DO3034-0-022	22	A	37	44	50	15
DO3034-0-024	24	A	40	44	50	16
DO3034-0-027	27	A	43	44	54	16
DO3034-0-030	30	C	47	44	54	21
DO3034-0-032	32	C	49	44	56	21
DO3034-0-033	33	C	51	44	56	22
DO3034-0-036	36	C	54	44	56	22
DO3034-0-038	38	C	57	44	58	24
DO3034-0-041	41	C	61	44	58	24
DO3034-0-046	46	C	67	44	63	27
DO3034-0-050	50	C	71	54	72	35
DO3034-0-055	55	C	77	54	74	35
DO3034-0-060	60	C	84	54	75	35

SIZE						
Hex Driver 6-Point (Inbus)						
Type	A/F	DRWG	D2	L	L1	-
	mm		mm	mm	mm	
Metrical						
DO696510A	10	D	44	100	20	-
DO696512A	12	D	44	100	20	-
DO696514A	14	D	44	100	20	-
DO696517A	17	D	44	100	20	-
DO696519A	19	D	44	100	20	-
DO696522A	22	D	44	100	20	-
DO696524A	24	D	44	100	20	-
DO696527A	27	D	44	100	20	-

SIZE						
Torx® internal						
Type	A/F	DRWG	D2	L	L1	-
	mm		mm	mm	mm	
DO64742050	T50	F	44	100	5,0	-
DO64742055	T55	F	44	100	5,5	-
DO64742060	T60	F	44	100	8,0	-
DO64742070	T70	F	44	100	9,4	-
DO64742080	T80	F	44	100	10,5	-
DO64742090	T90	F	44	100	11,8	-
DO64742100	T100	F	44	100	13,1	-

SIZE						
12-point normal						
Type	A/F	DRWG	D1	D2	L	L2
	mm		mm	mm	mm	mm
Metrical						
DO63845013	13	A	23	38	50	12
DO63845014	14	A	24	38	50	12
DO63845015	15	A	26	38	50	12
DO63845016	16	A	27	38	50	12
DO63845017	17	A	28	38	50	12
DO63845018	18	A	29	38	50	12
DO63845019	19	A	30	38	50	14
DO63845020	20	A	31	38	52	16
DO63845021	21	A	32	38	52	16
DO63845022	22	A	34	38	52	16
DO63845023	23	A	35	38	52	16
DO63845024	24	A	36	38	52	18
DO63845025	25	B	38	38	52	18
DO63845026	26	C	40	38	52	23
DO63845027	27	C	40	38	52	23
DO63845028	28	C	42	38	52	23
DO63845029	29	C	43	38	52	23
DO63845030	30	C	43	38	52	23
DO63845031	31	C	44	38	56	24
DO63845032	32	C	45	38	56	24
DO63845033	33	C	46	38	56	24
DO63845034	34	C	48	38	56	24
DO63845035	35	C	50	38	56	24
DO63845036	36	C	51	38	56	24
DO63845037	37	C	52	38	56	24
DO63845038	38	C	53	38	56	24
DO63845039	39	C	55	38	62	28
DO63845041	41	C	58	38	62	28
DO63845042	42	C	61	38	62	28
DO63845043	43	C	63	38	62	28
DO63845046	46	C	67	38	68	33
DO63845050	50	C	71	38	70	34
DO63845055	55	C	77	54	74	35
DO63845056	56	C	77	54	74	35

Other versions of impact sockets are available (magnetic, thinwalled, other sizes). Ask for our special socket-catalogue on page 4.

Impact sockets

1"

SIZE											
6-Point normal						deep					
Type	A/F mm	DRWG	D1 mm	D2 mm	L mm	L2 mm	Type	L mm	L2 mm		
Metrical											
DO4010-0-017	17	A	34	54	58	12	DO4010-1-017	100	21		
DO4010-0-019	19	A	35,5	54	58	13	DO4010-1-019	100	21		
DO4010-0-022	22	A	40	54	58	15	DO4010-1-022	100	21		
DO4010-0-024	24	A	42	54	58	19	DO4010-1-024	100	21		
DO4010-0-027	27	A	46	54	58	19	DO4010-1-027	100	23		
DO4010-0-028	28	A	47	54	58	19	DO4010-1-028	100	23		
DO4010-0-029	29	A	48	54	60	19	DO4010-1-029	100	50		
DO4010-0-030	30	A	50	54	60	21	DO4010-1-030	100	50		
DO4010-0-032	32	A	52	54	60	21	DO4010-1-032	100	50		
DO4010-0-033	33	A	53	54	60	21	DO4010-1-033	100	50		
DO4010-0-036	36	C	57	54	65	25	DO4010-1-036	100	64		
DO4010-0-038	38	C	59,5	54	67	25	DO4010-1-038	100	64		
DO4010-0-041	41	C	64	54	74	27	DO4010-1-041	100	64		
DO4010-0-042	42	C	65	54	74	27	DO4010-1-042	100	64		
DO4010-0-046	46	C	69,5	54	74	30	DO4010-1-046	100	62		
DO4010-0-050	50	C	74	54	80	35	DO4010-1-050	100	62		
DO4010-0-055	55	C	81	54	84	35	DO4010-1-055	100	60		
DO4010-0-060	60	C	87	54	87	42	DO4010-1-060	105	77		
DO4010-0-065	65	C	93	54	90	42	DO4010-1-065	120	80		
DO4010-0-070	70	C	100	54	96	42	DO4010-1-070	125	80		
DO4010-0-075	75	C	104	86	98	45	DO4010-1-075	135	87		
DO4010-0-080	80	C	109	86	100	48	DO4010-1-080	135	87		

SIZE											
12-Point normal						deep					
Type	A/F mm	DRWG	D1 mm	D2 mm	L mm	L2 mm	Type	L mm	L2 mm		
Metrical											
DO65855016	16	A	32	54	60	11	DO65857016	100	11		
DO65855017	17	A	34	54	60	11	DO65857017	100	11		
DO65855018	18	A	35	54	60	13	DO65857018	100	13		
DO65855019	19	A	36	54	60	13	DO65857019	100	13		
DO65855020	20	A	37	54	60	13	DO65857020	100	13		
DO65855021	21	A	38	54	60	15	DO65857021	100	15		
DO65855022	22	A	39	54	60	15	DO65857022	100	15		
DO65855023	23	A	40	54	60	15	DO65857023	100	15		
DO65855024	24	A	41	54	60	18	DO65857024	100	18		
DO65855025	25	A	43	54	60	18	DO65857025	100	18		
DO65855026	26	A	44,5	54	60	18	DO65857026	100	18		
DO65855027	27	A	45	54	60	19	DO65857027	100	19		
DO65855028	28	A	46,5	54	62	19	DO65857028	100	19		
DO65855029	29	A	48	54	62	19	DO65857029	100	19		
DO65855030	30	A	50	54	62	21	DO65857030	100	21		

SIZE											
12-Point normal						deep					
Type	A/F mm	DRWG	D1 mm	D2 mm	L mm	L2 mm	Type	L mm	L2 mm		
Metrical											
DO65855031	31	A	51	54	62	21	DO65857031	100	21		
DO65855032	32	A	52	54	62	22	DO65857032	100	22		
DO65855033	33	A	53	54	62	22	DO65857033	100	22		
DO65855034	34	C	55	54	62	22	DO65857034	100	22		
DO65855035	35	C	56	54	65	22	DO65857035	100	22		
DO65855036	36	C	57	54	67	24	DO65857036	100	24		
DO65855037	37	C	59	54	67	24	DO65857037	100	24		
DO65855038	38	C	60	54	67	24	DO65857038	100	24		
DO65855039	39	C	61	54	70	24	DO65857039	100	24		
DO65855040	40	C	62	54	70	24	DO65857040	100	24		
DO65855041	41	C	63,5	54	70	27	DO65857041	100	27		
DO65855042	42	C	65	54	74	27	DO65857042	100	27		
DO65855043	43	C	66	54	74	27	DO65857043	100	27		
DO65855044	44	C	67	54	74	27	DO65857044	100	27		
DO65855045	45	C	68	54	74	27	DO65857045	100	27		
DO65855046	46	C	70	58	76	30	DO65857046	100	30		
DO65855047	47	C	71,5	58	76	30	DO65857047	100	30		
DO65855048	48	C	72,5	58	76	30	DO65857048	100	30		
DO65855050	50	C	75	62	80	32	DO65857050	100	32		
DO65855051	51	C	76	62	80	32	DO65857051	100	32		
DO65855052	52	C	77	62	84	32	DO65857052	100	32		
DO65855053	53	C	78	62	84	32	DO65857053	100	32		
DO65855054	54	C	80	62	84	32	DO65857054	100	32		
DO65855055	55	C	81	62	84	35	DO65857055	100	35		
DO65855056	56	C	82	62	84	35	DO65857056	105	35		
DO65855057	57	C	84	62	84	35	DO65857057	105	35		
DO65855058	58	C	85	62	87	37	DO65857058	105	37		
DO65855060	60	C	87	62	87	37	DO65857060	120	37		
DO65855062	62	C	89	62	87	37	DO65857062	120	37		
DO65855063	63	C	90	62	87	37	DO65857063	120	37		
DO65855065	65	C	93	62	90	40	DO65857065	125	40		
DO65855067	67	C	96	62	92	40	DO65857067	125	40		
DO65855070	70	C	100	62	96	40	DO65857070	125	40		
DO65855075	75	C	106	86	98	42	DO65857075	135	42		
DO65855076	76	C	107	86	100	45	DO65857076	135	45		
DO65855077	77	C	109	86	100	45	DO65857077	135	45		
DO65855078	78	C	110	86	100	45	DO65857078	135	45		
DO65855080	80	C	112	86	100	45	DO65857080	135	45		
DO65855085	85	C	118	86	105	52	DO65857085	140	52		
DO65855090	90	C	125	86	105	52	DO65857090	140	52		
DO65855095	95	C	131	86	105	52	DO65857095	140	52		
DO65855100	100	C	137	86	110	58	DO65857100	140	58		
DO65855105	105	C	143	95	110	58	DO65857105	155	58		
DO65855110	110	C	149	95	115	62	DO65857110	155	62		
DO65855115	115	C	155	95	115	62	DO65857115	155	62		

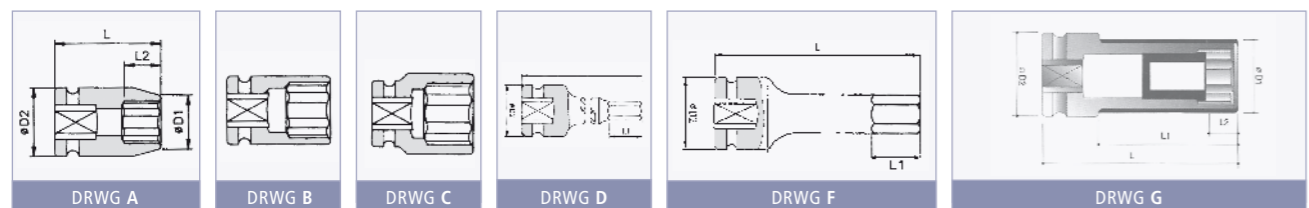

Impact sockets

1"

SIZE						
Hex Driver 6-Point (Inbus)						
Type	A/F mm	DRWG	D2 mm	L mm	L1 mm	-
DO696610A	10	D	54	100	20	-
DO696612A	12	D	54	100	20	-
DO696614A	14	D	54	100	20	-
DO696617A	17	D	54	100	20	-
DO696619A	19	D	54	100	20	-
DO696622A	22	D	54	100	20	-
DO696624A	24	D	54	100	20	-
DO696627A	27	D	54	100	20	-
DO696630A	30	D	54	100	20	-
DO696632A	32	D	54	100	20	-

1 1/2"

SIZE											
12-Point normal						deep					
Type	A/F mm	DRWG	D1 mm	D2 mm	L mm	L2 mm	Type	L mm	L2 mm		
Metrical											
DO5112-0-030	30	A	56	86	78	23	-	-	-		
DO5112-0-036	36	A	64	86	78	23	-	-	-		
DO5112-0-038	38	A	66	86	78	24	-	-	-		
DO5112-0-041	41	A	70	86	80	26	DO5112-1-041	115	30		
DO5112-0-045	45	A	75	86	84	27	-	-	-		
DO5112-0-046	46	A	76	86	84	27	DO5112-1-046	115	34		
DO5112-0-047	47	A	77	86	84	29	-	-	-		
DO5112-0-050	50	A	81	87	87	29	DO5112-1-050	135	36		
DO5112-0-052	52	A	83	86	87	31	-	-	-		
DO5112-0-054	54	B	86	86	90	36	DO5112-1-054	140	37		
DO5112-0-055	55	B	86	86	90	36	DO5112-1-055	140	37		
DO5112-0-056	56	B	86	86	92	38	DO5112-1-056	140	37		
DO5112-0-058	58	C	92	86	92	38	-	-	-		
DO5112-0-060	60	C	93	86	92	38	DO5112-1-060	150	41		
DO5112-0-065	65	C	97	86	95	40	DO5112-1-065	150	45		
DO5112-0-070	70	C	105	86	100	43	DO5112-1-070	160	47		
DO5112-0-075	75	C	110	86	103	45	DO5112-1-075	170	51		
DO5112-0-080	80	C	116	86	110	50	DO5112-1-080	170	51		
DO5112-0-085	85	C	125	86	118	55	DO5112-1-085	170	56		
DO5112-0-090	90	C	130	86	118	55	DO5112-1-090	170	59		
DO5112-0-095	95	C	137	95	118	55	DO5112-1-095	180	61		
DO5112-0-100	100	C	140	95	125	58	DO5112-1-100	190	65		
DO5112-0-105	105	C	150	95	125	58	DO5112-1-105	190	68		

Impact sockets

Impact sockets (sets)

Extension bars & Universal joints

Universal joints with pin hole

Type	Square-drive	DRWG	D2 mm	L mm	-	-
DO9038-0-000	3/8"	B	21	50	-	-
DO9012-0-000	1/2"	B	29	60	-	-
DO9034-0-000	3/4"	B	44	105	-	-
DO9100-0-000	1"	B	54	133	-	-

Extension Bars with pin-hole

Type	Square-drive	DRWG	D2 mm	L mm	-	-
DO7014-0-050	1/4"	D	13	50	-	-
DO7014-0-100	1/4"	D	13	100	-	-
DO7038-0-075	3/8"	D	19	75	-	-
DO7038-0-125	3/8"	D	19	125	-	-
DO7038-0-150	3/8"	D	19	150	-	-
DO7012-0-075	1/2"	D	25	75	-	-
DO7012-0-125	1/2"	D	25	125	-	-
DO7012-0-250	1/2"	D	25	250	-	-
DO7012-0-460	1/2"	D	25	460	-	-
DO7034-0-100	3/4"	D	44	100	-	-
DO7034-0-175	3/4"	D	44	175	-	-
DO7034-0-250	3/4"	D	44	250	-	-
DO7100-0-175	1"	D	54	175	-	-
DO7100-0-200	1"	D	54	200	-	-
DO7100-0-250	1"	D	54	250	-	-
DO7100-0-400	1"	D	54	400	-	-
DO7112-0-250	1 1/2"	D	86	250	-	-
DO7212-0-500	2 1/2"	D	127	500	-	-

Pins and Rings

Type	Square-drive	D2 mm
DO1014-0-000	1/4"	-
DO1038-0-000	3/8"	-
DO1012-0-000	1/2"	-
DO1034-0-000	3/4"	-
DO1100-0-000	1"	84
DO1100-0-086	1"	86
DO1100-0-095	1"	95
DO1112-0-000	1 1/2"	86
DO1112-0-095	1 1/2"	95
DO2112-0-127	1 1/2"	127
DO2112-0-000	2 1/2"	-



Other versions of impact sockets are available (magnetic, thinwalled, other sizes). Ask for our special socket-catalogue on page 4.

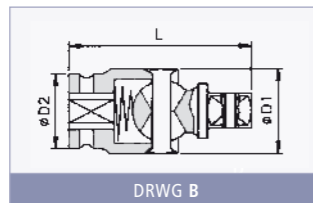
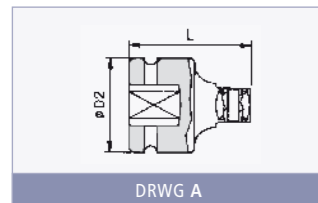

Adaptors

Adaptors with pin hole

Type	Square-drive	Outside	DRWG	D2 mm	L mm	-
DO8038-0-012	3/8"	1/2"	A	22	36	-
DO8012-0-034	1/2"	3/4"	A	30	48	-
DO8012-0-038	1/2"	3/8"	A	26	38	-
DO8034-0-012	3/4"	1/2"	A	40	58	-
DO8034-0-100	3/4"	1"	A	40	63	-
DO8100-0-034	1"	3/4"	A	52	80	-

Impact adaptors

Type	Square-drive	Hex drive	DRWG	L mm	D mm	-
DO69306050	1/4"	1/4"	C	50	9	-
DO69306075	1/4"	1/4"	C	75	9	-
DO69306100	1/4"	1/4"	C	100	9	-
DO69306150	1/4"	1/4"	C	150	9	-
DO69316050	3/8"	1/4"	C	50	13	-
DO69316075	3/8"	1/4"	C	75	13	-
DO69316100	3/8"	1/4"	C	100	13	-
DO69318075	3/8"	7/16"	D	75	13	-
DO69328075	1/2"	7/16"	D	75	17	-

Quick-Change adaptors



Quick-Change adaptors

Type	Drive-in	Drive-out	L mm	-	-
DO69110C08	1/4"	1/4"	35	-	-
DO69111C12	3/8"	3/8"	46	-	-
DO69112C12	1/2"	3/8"	54	-	-
DO69112C16	1/2"	1/2"	60	-	-
DO69114C24	3/4"	3/4"	78	-	-
DO69115C24	1"	3/4"	90	-	-
DO69115C32	1"	1"	100	-	-

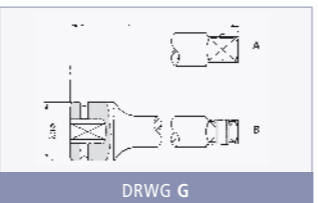
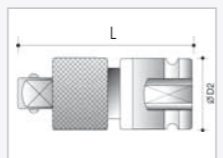

Stud Bolt Setters

Stud Bolt Setters

Type 3/8"	Size	D2 mm	D1 mm	L mm
DO69781053	M6x1,0	22	12,5	50
DO69781060	M8x1,25	22	14,5	50
DO69781063	M10x1,5	22	17	50
DO69781066	M12x1,75	22	19	50

Stud Bolt Setters

Type 1/2"	Size	D1 mm	D2 mm	L mm
DO69782010	M6 x P1,0	25	13	55
DO69782018	M8 x P1,25	25	15	55
DO69782022	M10 x P1,5	25	17	55
DO69782027	M12 x P1,75	25	19	55
DO69782031	M14 x P2,0	25	22	55
DO69782035	M16 x P2,0	30	27	75

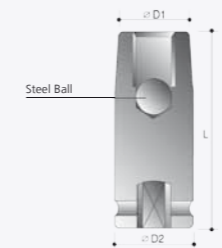

Also available with other pitch.

Tap holding sockets

SIZE

Tap holding sockets

Type 3/8	A mm	Ø d mm	L mm	Type 1/2	A mm	Ø d mm	L mm
----------	------	--------	------	----------	------	--------	------

Metrical

DO6321B001	3,4	4,5	38	DO6322B001	3,4	4,5	40
DO6321B002	4,9	6,0	38	DO6322B002	4,9	6,0	45
DO6321B003	5,5	7,0	40	DO6322B003	5,5	7,0	45
DO6321B004	6,2	8,0	40	DO6322B004	6,2	8,0	45
DO6321B005	7,0	9,0	43	DO6322B005	7,0	9,0	45
DO6321B006	8,0	10,0	45	DO6322B006	8,0	10,0	45
DO6321B007	9,0	11,0	45	DO6322B007	9,0	11,0	45
DO6321B008	9,0	12,0	45	DO6322B008	9,0	12,0	50
DO6321B009	11,0	14,0	45	DO6322B009	11,0	14,0	52

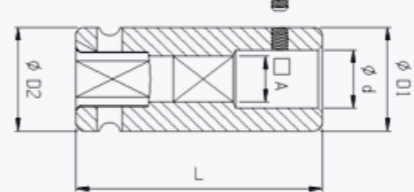

Wheel nut impact socket set long (L=85)

DO69523031

Contents:
3 impact sockets with plastic stop and sleeve
blue 17 mm - yellow 19 mm - red 21 mm
Package: blow-mold-case



Impact sockets are also available as single pockets

Type	A/F mm	Colour	D1 mm	D2 mm	L mm	L1 mm	L2 mm
DO61126015	15	white	25	30	85	60	13
DO61126017	17	blue	27	30	85	60	14
DO61126019	19	yellow	29	30	85	60	15
DO61126021	21	red	31	30	85	60	17
DO61126022	22	green	32,5	30	85	60	18

For optimal protection of aluminium rims, sockets with plastic stop and sleeve in five different colours for easy identification.

Wheel nut impact socket set extra long (L=130)

DO61120310

Contents:
3 impact sockets with plastic stop and sleeve
blue 17 mm - yellow 19 mm - red 21 mm
Package: blow-mold-case



Impact sockets are also available as single pockets

Type	A/F mm	Colour	D1 mm	D2 mm	L mm	L1 mm	L2 mm
DO6112J017	17	blue	27	25	130	87	24
DO6112J019	19	yellow	29	30	130	87	24
DO6112J021	21	red	31	30	130	87	24
DO6112J022	22	green	32,5	30	130	87	24

For optimal protection of aluminium rims, sockets with plastic stop and sleeve in five different colours for easy identification.

Impact socket sets

Impact socket sets

Impact socket set

DO0038-0-010

3/8"

Contents:
10 impact sockets, normal sizes
9 - 10 - 11 - 12 - 13 - 14 - 15 - 16 - 17 - 19 mm
Package: metal case



Impact socket set

DO605121301

3/8"

Contents:
13 impact sockets, 6-Point deep, normal sizes 7 - 8 - 9 - 10, 11 - 12 - 13 - 14 - 15 - 16 - 17 - 18 - 19 mm
Package: blow mold case



Impact socket set

DO0012-0-0005

1/2"

Contents:
10 impact sockets, normal sizes
9 - 10 - 11 - 13 - 14 - 17 - 19 - 22 - 24 - 27 mm
Package: metal case



Special socket set for wheel lug nut

DO0012-1-286

1/2"

Contents:
Socketset 8 pcs. lug nut remover sockets
17 - 18,5 - 20 - 21,5 - 23 - 24,5 - 26 - 27,5 mm
Package: blow-mold-case



Special socket set for wheel lug nut

DO0012-0-286

1/2"

Contents:
7 pcs of lug nut remover sockets,
17 - 18,5 - 20 - 21,5 - 23 - 24,5 - 26 mm
Package: blow-mold-case



Application wheel lug nut remover sockets

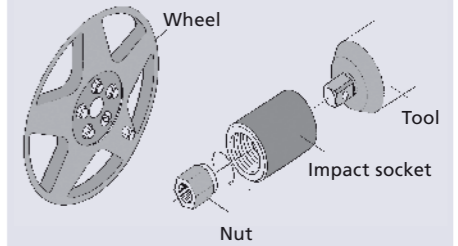

Hex Head Set

DO69521093

1/2"

Contents:
9 Hex Head power sockets
4 - 5 - 6 - 8 - 10 - 12 - 14 - 17 - 19 mm
Package: metal case



Impact socket set, deep

DO605222601

1/2"

Contents:
26 impact sockets, 6-Point deep
10, 11, 12, 13, 14, 15, 16, 17, 18, 19, 20, 21mm, 22, 23, 24, 25, 26, 27, 28, 29, 30, 32, 33, 34, 35, 36 mm
Package: blow-mold case



Impact socket set

DO605202601

1/2"

Contents:
26 impact sockets, 6-Point
10, 11, 12, 13, 14, 15, 16, 17, 18, 19, 20, 21, 22, 23, 24, 25, 26, 27, 28, 29, 30, 32, 33, 34, 35, 36 mm
Package: blow-mold-case



Impact socket set

DO0034-0-008

3/4"

Contents:
8 impact sockets, normal sizes
24 - 27 - 30 - 32 - 33 - 36 - 38 - 41 mm
Package: metal case



Impact socket set, deep

DO605421001

3/4"

Contents:
10 impact sockets, 6-Point, deep
21 - 22 - 24 - 27 - 30 - 32 - 33 - 36 - 41 - 46 mm
Package: blow-mold-case



15 Piece truckrepair set

DO69643151

1"

3/4"

Contents:
1) 5 Impact sockets Torx® internal T60, T70, T80, T90, T100
2) 4 Impact sockets Torx® external E18, E20, E22, E24
3) 4 Impact sockets internal hex 17 - 19 - 22 - 24 mm
4) + 3/4" and 1" hexagon bitholder 22 mm + Hexagon spanner 2,5 mm

Package: blow-mold-case

Type	Order number
1) Torx® internal T60	DO697LB060
Torx® internal T70	DO697LB070
Torx® internal T80	DO697LB080
Torx® internal T90	DO697LB090
Torx® internal T100	DO697LB100
2) Torx® external E18	DO697RB118
Torx® external E20	DO697RB120
Torx® external E22	DO697RB122
Torx® external E24	DO697RB124
3) Internal hex 17 mm	DO697RB017
Internal hex 19 mm	DO697RB019
Internal hex 22 mm	DO697RB022
Internal hex 24 mm	DO697RB024
4) 3/4" hex bitholder 22 mm	DO6054H022
1" hex bitholder 22 mm	DO6055N022

Impact socket set, deep

DO69523108

1/2"

Contents:
10 deep impact sockets
10 - 11 - 13 - 14 - 17 - 19 - 21 - 22 - 24 - 27 mm
Package: blow-mold case



Impact socket set

DO652260701

1/2"

Contents:
7 pcs 1/2" dr., impact triple square driver set
M5, M6, M8, M10, M12, M14, M16
Package: blow-mold case



Impact Socket Set 1/2" & bits

DO691121301

1/2"

Contents:
1pc. 1/2" Square Drive, 7/16" Hex. Quick Releasing Chuck.
6 pcs 7/16" Hex Internal Torx Bits: T30, T40, T45, T50, T55, T60
6 pcs 7/16" Hex Hexagon Driver: 6 - 8 - 10 - 12 - 14 - 17 mm
Package: blow-mold case



Impact socket set long

DO0100-1-007

1"

Contents:
7 impact sockets, deep
24 - 27 - 30 - 32 - 33 - 36 - 41 mm
Package: blow-mold-case



Impact Socket Set magnetic reducers

DO698800401

Contents:
4 pcs. magnetic sleeve insert adaptors
Magnetic reducing sleeve 1/4" F x 3/8" M
Magnetic reducing sleeve 3/8" F x 1/2" M
Magnetic reducing sleeve 1/2" F x 3/4" M
Magnetic reducing sleeve 3/4" F x 1" M
Package: blow-mold-case



Ratchet wrenches



Ratchet wrenches 1/4" - 3/8" - 1/2" Square drive

Type	Brand	Square-drive	Bolt capacity mm	RPM	Torque Nm	Air-consumption l/s	Weight kg	Inlet-thread	Hose-diameter mm	Vibration m/s ²	Noise-level dB(A)
RRW-2202	RRA	1/4"	8	270	32	5,0	0,5	PT 1/4"	6,5	4,3	85
MR-2207C	TOKU	1/4"	8	250	28	5,0	0,5	PT 1/4"	6,5	2,7	81
RRW-2203	RRA	3/8"	10	270	32	5,0	0,5	PT 1/4"	6,5	4,3	85
MR-2209C	TOKU	3/8"	10	250	28	5,0	0,5	PT 1/4"	6,5	2,7	81
RRW-2403	RRA	3/8"	12	150	68	6,0	1,2	PT 1/4"	6,5	5,8	85
MR-2310B	TOKU	3/8"	12	175	78	6,0	1,2	PT 1/4"	6,5	3	85
RRW-2404	RRA	1/2"	12	150	68	6,0	1,2	PT 1/4"	6,5	5,8	85
MR-2410B	TOKU	1/2"	12	175	78	6,0	1,2	PT 1/4"	6,5	1,3	81
RRW-121	RRA	1/2"	12	135	120	8,0	1,9	PT 1/4"	10	2,3	88

Reactionless ratchet wrenches

RRW-3403	RRA	3/8"	12	500	95	6,0	1,28	PT 1/4"	6,5	4,5	91
RRW-3404	RRA	1/2"	12	500	95	6,0	1,28	PT 1/4"	6,5	4,5	91

Ratchet wrenches for the assembly industry

YRW-6	YOKOTA	8, 9, 10 *	6	200	13	4,6	1,15	PT 1/4"	6,5	2,5	81
YRW-8NS	YOKOTA	10, 12, 13, 14 *	8	250	30	8,3	2,00	PT 1/4"	10	2,5	82
YRW-10N	YOKOTA	14, 17 *	10	140	45	11,6	2,65	PT 1/4"	10	2,5	84

* Socket size in mm. Please state socket size in your order.

Type	DIMENSIONS						
	A mm	B mm	C mm	D mm	E mm	F mm	
MR-2207C	165	33	-	-	-	-	
MR-2209C	165	33	-	-	-	-	
MR-2310B	255	44	-	-	-	-	
MR-2410B	255	50	-	-	-	-	
RRW-121	357	57	-	-	-	-	
RRW-2202	180	32	-	-	-	-	
RRW-2203	180	32	-	-	-	-	
RRW-2403	250	40	-	-	-	-	
RRW-2404	250	45	-	-	-	-	
RRW-3403	280	40	-	-	-	-	
RRW-3404	280	45	-	-	-	-	
YRW-6	320	13	13	88	20	10	
YRW-8NS	350	18	13	105	25	12,5	
YRW-10N	388	18	18	108	33	16,5	

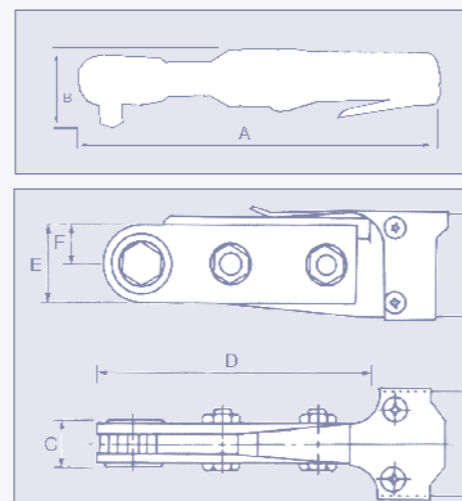

Screwdrivers

Hammermechanism / Direct drive



Type	Brand	Hex drive	Bolt capacity mm	Model	RPM	Torque Nm	Air-cons. l/s	Weight kg	Inlet-thread	Hose-diameter mm	Vibration m/s ²	Noise level dB(A)
------	-------	-----------	------------------	-------	-----	-----------	---------------	-----------	--------------	------------------	----------------------------	-------------------

1-Hammer

YD-3A ¹⁾	YOKOTA	1/4" Hex	4	Straight	12.000	7,5	1,6	0,50	PT 1/8"	6,5	2,3	82
YD-4A ¹⁾	YOKOTA	1/4" Hex	5	Straight	11.000	12,0	2,3	0,60	PT 1/8"	6,5	2	90
YD-5A ¹⁾	YOKOTA	1/4" Hex	6	Straight	10.000	15,5	3,2	0,85	PT 1/8"	6,5	2,5	90

2-Hammer

MID-600 ²⁾	TOKU	1/4" Hex	3-5	Pistol	9.500	90	5,0	0,9	PT 1/4"	6,5	3,6	82
YD-40PZ	YOKOTA	1/4" Hex	4	Pistol	14.000	15	1,6	0,52	PT 1/4"	6,5	4	80
YD-600SZ ²⁾	YOKOTA	1/4" Hex	6	Straight	7.500	37	5,0	0,95	PT 1/4"	6,5	1,6	77
YD-670A-RF ³⁾	YOKOTA	1/4" Hex	6	Pistol	7.500	90	6,1	0,98	PT 1/4"	6,5	1,5	75

Direct drive

RR-0800DD	RRA	1/4" Hex	6	Pistol	800	10,5	9,8	1,0	PT 1/4"	10	3,5	83
RR-1800DD	RRA	1/4" Hex	6	Pistol	1.800	7,5	9,8	1,0	PT 1/4"	10	3,5	83

¹⁾ Supplied with regulator
²⁾ Air supply adjustable with 4 step button
³⁾ Supplied with rubber protection cover

CONTROL	1-Hammer		Direct drive	
	YD-3A	Push start	RR-0800DD	Trigger start
YD-4A	Push start	RR-1800DD	Trigger start	
YD-5A	Push start			
2-Hammer		Clutch type mechanism		
MID-600	Trigger start	YD-400SCA	Push start	
YD-40PZ	2-step trigger	YD-5PHCA	2-step trigger	
YD-600SZ	Lever control	RR-06SP/RR-02SP	Trigger start	
YD-670A-RF	2-step trigger	RR-02SC/RR-06SC	Lever start	

Screwdrivers

DIMENSIONS

Typ	A mm	B mm	C mm
MID-600	149	22	161
RR-02SP / RR-06SP	214	-	165
RR-06SC	227	150	155
RR-02SC	260	50	-
RR-0800DD	190	-	165
RR-1800DD	175	-	165

Typ	A mm	B mm	C mm
YD-3A	168	13,5	-
YD-4A	180	16	-
YD-5A	200	19	-
YD-5PHCA	217	20	154
YD-40PZ	107	18	125
YD-400SCA	209	16,5	-
YD-600SZ	206	23	-
YD-670A-RF	149	22	167

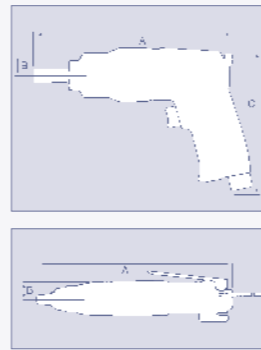

All screwdrivers adapt 1/4" standard type hexagon insert bits and are reversible.

Screwdrivers

Clutch type mechanism (adjustable)



Type	Brand	Square hex drive	Bolt capacity mm	Model	RPM	Torque Nm	Air-cons. l/s	Weight kg	Inlet-thread	Hose-diameter mm	Vibration m/s ²	Noise-level dB(A)
YD-400SCA	YOKOTA	1/4" Hex	4	Straight	1.700	1 - 3,2	2,5	0,56	PT 1/8"	6,5	4	77
RR-02SC	RRA	1/4" Hex	5	Straight	1.800	1 - 6	10,0	1,2	PT 1/4"	10	1,6	85
RR-06SC	RRA	1/4" Hex	6	Straight	800	5 - 16	10,0	1,4	PT 1/4"	10	1,6	85
YD-5PHCA	YOKOTA	1/4" Hex	5	Pistol	1.650	1 - 6,6	5,8	1,2	PT 1/4"	6,5	2	77
RR-02SP	RRA	1/4" Hex	5	Pistol	1.800	1 - 6	10,0	1,3	PT 1/4"	10	1,6	85
RR-06SP	RRA	1/4" Hex	6	Pistol	800	5 - 16	10,0	1,4	PT 1/4"	10	3,5	83

TiD-extra
Industrial Technologies d.o.o.

IMPACT SOCKETS FOR SCREWDRIVERS

SIZE

6-Point

Type	A/F mm	DRWG	D1 mm	L mm	L1 mm
Metrical					
DO697B0S04	4	A	8	55	4,5
DO697B0S06	6	A	10	55	4,5
DO697B0T06	6	A	10	75	4,5
DO697B0T07	7	A	11	75	4,5
DO697B0T08	8	A	12	75	4,5
DO697B0T10	10	A	14	75	5,5
DO697B0T12	12	A	17	75	5,5
DO697B0T13	13	A	18	75	5,5
DO697B0T14	14	A	19	75	5,5

SIZE

6-Point magnetic

Type	A/F mm	DRWG	D1 mm	L mm	L1 mm
Metrical					
DO697B0M06	6	10	55	4,5	4,5
DO697B0M07	7	11	55	4,5	4,5
DO697B0M08	8	12	55	4,5	5,5
DO697B0M10	10	14	55	5,5	5,5
DO697B0M11	11	16	55	5,5	5,5
DO697B0M12	12	17	55	5,5	5,5
DO697B0M13	13	18	55	5,5	5,5
DO697B0M14	14	19	55	5,5	4,5
DO697B0P06	6	10	100	4,5	4,5
DO697B0P07	7	11	100	4,5	5,5
DO697B0P08	8	12	100	4,5	5,5
DO697B0P10	10	14	100	5,5	5,5
DO697B0P12	12	17	100	5,5	5,5
DO697B0P13	13	18	100	5,5	5,5
DO697B0P14	14	19	100	5,5	5,5
DO697B0P17	17	23	100	7	5,5

SIZE

6-Point deep magnetic

Type	A/F mm	DRWG	D1 mm	L mm	L1 mm
Metrical					
DO697B7006	6	C	10	100	4,5
DO697B7008	8	C	12	100	4,5
DO697B7010	10	C	14	100	5,5
DO697B7012	12	C	17	100	5,5
DO697B7013	13	C	18	100	5,5
DO697B7014	14	C	19	100	5,5
DO697B9006	6	C	10	200	4,5
DO697B9008	8	C	12	200	4,5
DO697B9010	10	C	14	200	5,5
DO697B9012	12	C	17	200	5,5
DO697B9013	13	C	18	200	5,5
DO697B9014	14	C	19	200	5,5

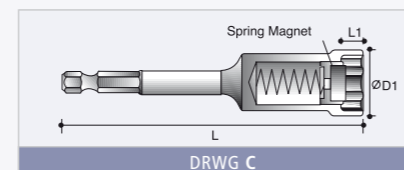
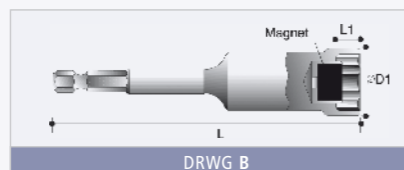
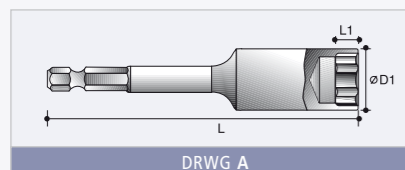

SELECTION GUIDE

What to choose

Type	Machine screw 4.8	Machine screw 8.8	Thread rolling screw-M	Thread forming screw-ST	Thread forming screw-ST, for plastic	Selfdrilling screw-ST	Wood screw
Impact	OK	OK	OK	OK	not OK	OK	OK
Direct drive	OK	OK	OK	OK	not OK	OK	OK
Clutch type mechanism	OK	OK	OK	OK	OK	OK	OK
Shut-off mechanism	OK	OK	OK	OK	OK	OK	OK

■ recommended ■ OK ■ not OK

Torque springs

Automotive models RR-06SP/SC and RR-02SP/SC are supplied with 3 torque springs (10 Nm low, 12 Nm medium and 16 Nm high).

Screw spanner

The YD-400SCA and YD-5PHCA are supplied as standard with set screw spanner number 2201-0234-00-00.

Spring balancers

The performance of the tool will be speeded up due to good balance and reduced operator fatigue, when using a spring balancer (p.75).

Shut-Off screwdrivers



Shut-Off screwdrivers



New serie RRI-screwdrivers for the assembly industry

The special design of the clutch combines low reaction forces with a high repeatability of the torque. This air tool is designed for the assembly industry, where threaded fasteners are used. The screwdriver can be connected by 4 mm O.D. tube to a YTC-3 controller for batch counting. These new Red Rooster screw drivers may be used with "oil free" air. In case of "oil free" air, it speaks for itself that the air quality (dry, clean) is of significant importance for the lifetime of the air motor. To achieve the optimal lifetime and performance of the air motor it is advised to lubricate the air (Red Rooster Atlub oil).

- CHARACTERISTICS**
- Large torque range
 - Highly accurate
 - Very low noise and vibration level
 - New pistol design in composite
 - Soft & ergonomic grip
 - Reversible
 - Rear-exhaust, silenced
 - Easily adjustable
 - Hanger included

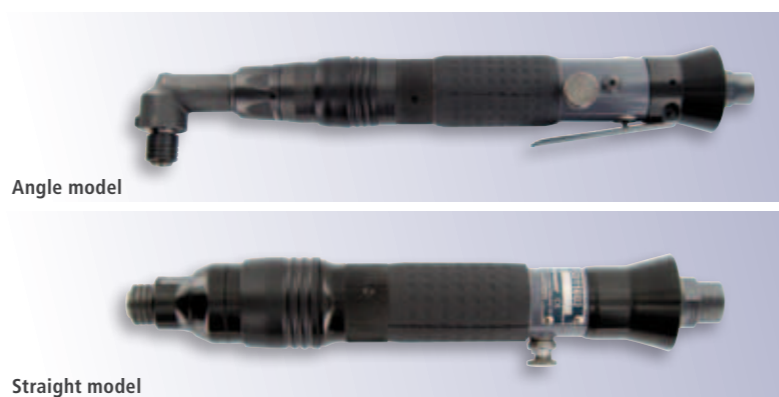

Pistol model

Type	Brand	Hex drive	Bolt capacity mm	RPM	Torque range Nm	Air-cons. l/s	Weight kg	Inlet-thread	Hose diameter mm	Vibration m/s ²	Noise level dB(A)
RRI-SP11602	RRI	1/4" Hex	4	1.600	0,3 - 1,8	8	0,77	PT 1/4"	6,5	<2,5	68
RRI-SP10902	RRI	1/4" Hex	4	900	0,3 - 2,2	8	0,77	PT 1/4"	6,5	<2,5	68
RRI-SP21704	RRI	1/4" Hex	4	1.700	1,0 - 3,5	10	0,98	PT 1/4"	6,5	<2,5	72
RRI-SP21104	RRI	1/4" Hex	4	1.100	1,5 - 4,0	10	0,98	PT 1/4"	6,5	<2,5	72
RRI-SP20705	RRI	1/4" Hex	4	700	1,5 - 4,5	10	0,98	PT 1/4"	6,5	<2,5	72
RRI-SP31706	RRI	1/4" Hex	5	1.700	3,5 - 6,0	12	1,1	PT 1/4"	6,5	<2,5	72
RRI-SP31108	RRI	1/4" Hex	5	1.100	3,5 - 8,0	12	1,1	PT 1/4"	6,5	<2,5	72
RRI-SP30710	RRI	1/4" Hex	6	700	3,5 - 10,0	12	1,1	PT 1/4"	6,5	<2,5	72
RRI-SP30511	RRI	1/4" Hex	6	550	3,5 - 11,0	12	1,1	PT 1/4"	6,5	<2,5	72

Angle model

Type	Brand	Square/Hex drive	Bolt capacity mm	RPM	Torque range Nm	Air-cons. l/s	Weight kg	Inlet-thread	Hose diameter mm	Vibration m/s ²	Noise level dB(A)
RRI-SA11602	RRI	1/4" Hex	4	1.600	0,3 - 1,8	8	0,82	1/4"	6,5	<2,5	68
RRI-SA10902	RRI	1/4" Hex	4	900	0,3 - 2,2	8	0,82	1/4"	6,5	<2,5	68
RRI-SA21704	RRI	1/4" Hex	4	1.700	1,0 - 3,5	10	1,02	1/4"	6,5	<2,5	72
RRI-SA21104	RRI	1/4" Hex	4	1.100	1,5 - 4,0	10	1,02	1/4"	6,5	<2,5	72
RRI-SA20705	RRI	1/4" Hex	4	700	1,5 - 4,5	10	1,02	1/4"	6,5	<2,5	72
RRI-SA31108	RRI	1/4" Hex	5	1.100	3,5 - 8,0	12	1,36	1/4"	6,5	<2,5	72
RRI-SA30710	RRI	1/4" Hex	6	700	3,5 - 10,0	12	1,36	1/4"	6,5	<2,5	72
RRI-SA30511	RRI	1/4" Hex	6	550	3,5 - 11,0	12	1,36	1/4"	6,5	<2,5	72
RRI-SA31108W	RRI	3/8" Square	5	1.100	3,5 - 8,0	12	1,36	3/8"	6,5	<2,5	72
RRI-SA30710W	RRI	3/8" Square	6	700	3,5 - 10,0	12	1,36	3/8"	6,5	<2,5	72
RRI-SA30511W	RRI	3/8" Square	6	550	3,5 - 11,0	12	1,36	3/8"	6,5	<2,5	72

Straight model

Type	Brand	Hex drive	Bolt capacity mm	RPM	Torque range Nm	Air-cons. l/s	Weight kg	Inlet-thread	Hose diameter mm	Vibration m/s ²	Noise level dB(A)
------	-------	-----------	------------------	-----	-----------------	---------------	-----------	--------------	------------------	----------------------------	-------------------

Shut-Off screwdrivers Push start type (not for connection to YTC-3 controller)

RRI-SD11602	RRI	1/4" Hex	4	1.600	0,3 - 1,8	8	0,54	1/4"	6,5	<2,5	68
RRI-SD10902	RRI	1/4" Hex	4	900	0,3 - 2,2	8	0,54	1/4"	6,5	<2,5	68
RRI-SD21704	RRI	1/4" Hex	4	1.700	1,0 - 3,5	10	0,77	1/4"	6,5	<2,5	72
RRI-SD21104	RRI	1/4" Hex	4	1.100	1,5 - 4,0	10	0,77	1/4"	6,5	<2,5	72
RRI-SD20705	RRI	1/4" Hex	4	700	1,5 - 4,5	10	0,77	1/4"	6,5	<2,5	72
RRI-SD31706	RRI	1/4" Hex	5	1.700	3,5 - 6,0	12	0,89	1/4"	6,5	<2,5	72
RRI-SD31108	RRI	1/4" Hex	5	1.100	3,5 - 8,0	12	0,89	1/4"	6,5	<2,5	72
RRI-SD30710	RRI	1/4" Hex	6	700	3,5 - 10,0	12	0,89	1/4"	6,5	<2,5	72
RRI-SD30511	RRI	1/4" Hex	6	550	3,5 - 11,0	12	0,89	1/4"	6,5	<2,5	72

Shut-Off screwdrivers lever start type

RRI-SL11602	RRI	1/4" Hex	4	1.600	0,3 - 1,8	8	0,59	1/4"	6,5	<2,5	68
RRI-SL10902	RRI	1/4" Hex	4	900	0,3 - 2,2	8	0,59	1/4"	6,5	<2,5	68
RRI-SL21704	RRI	1/4" Hex	4	1.700	1,0 - 3,5	10	0,84	1/4"	6,5	<2,5	72
RRI-SL21104	RRI	1/4" Hex	4	1.100	1,5 - 4,0	10	0,84	1/4"	6,5	<2,5	72
RRI-SL20705	RRI	1/4" Hex	4	700	1,5 - 4,5	10	0,84	1/4"	6,5	<2,5	72
RRI-SL31706	RRI	1/4" Hex	5	1.700	3,5 - 6,0	12	0,93	1/4"	6,5	<2,5	72
RRI-SL31108	RRI	1/4" Hex	5	1.100	3,5 - 8,0	12	0,93	1/4"	6,5	<2,5	72
RRI-SL30710	RRI	1/4" Hex	6	700	3,5 - 10,0	12	0,93	1/4"	6,5	<2,5	72
RRI-SL30511	RRI	1/4" Hex	6	550	3,5 - 11,0	12	0,93	1/4"	6,5	<2,5	72

DIMENSIONS

TYPE (DRAWING A)	A mm	B mm	C mm	TYPE (DRAWING C)	A mm	B mm
RRI-SP11602	198	16	157	RRI-SD11602	228	16
RRI-SP10902	198	16	157	RRI-SD10902	228	16
RRI-SP21704	209	18	157	RRI-SD21704	244	18
RRI-SP21104	209	18	157	RRI-SD21104	244	18
RRI-SP20705	209	18	157	RRI-SD20705	244	18
RRI-SP31706	238	18	156	RRI-SD31706	276	18
RRI-SP31108	238	18	157	RRI-SD31108	276	18
RRI-SP30710	238	18	157	RRI-SD30710	276	18
RRI-SP30511	238	18	157	RRI-SD30511	276	18

TYPE (DRAWING B)	A mm	B mm	C mm	E mm	TYPE (DRAWING C)	A mm	B mm
RRI-SA11602	294	29	16,1	12	RRI-SL11602	244	16
RRI-SA10902	294	29	16,1	12	RRI-SL10902	244	16
RRI-SA21704	314	29	16,1	12	RRI-SL21704	263	18
RRI-SA21104	314	29	16,1	12	RRI-SL21104	263	18
RRI-SA20705	314	30,5	15,8	13,5	RRI-SL20705	263	18
RRI-SA31108	350	30,5	15,8	13,5	RRI-SL31706	263	18
RRI-SA30710	350	30,5	15,8	13,5	RRI-SL31108	309	18
RRI-SA30511	350	30,5	15,8	13,5	RRI-SL30710	309	18
RRI-SA31108W	350	30,5	15,8	13,5	RRI-SL30511	309	18
RRI-SA30710W	350	30,5	15,8	13,5			
RRI-SA30511W	350	30,5	15,8	13,5			

Cordless shut-off screwdriver



For assembly applications where torque accuracy is required and areas where pneumatic or electric tools are impractical to use due to hoses/cables.

Characteristics:

- Brushless motor
- 18 Volt Lithium-Ion battery
- Led status indicates
OK - NOK - REVERSE - BATTERY LOW
- Adjustable torque
- Speed 250 to 1.550 RPM
- Compact and light weight



Drills



Pistol models

Type	Brand	Capacity steel mm	Spindle size	Rotation direction	RPM	Power kW	Air-cons. l/s	Weight kg	Inlet-thread	Hose diameter mm	Vibration m/s ²	Noise level dB(A)
RRI-2006	RRI	6,5	3/8" x 24 UNF	R	5.000	0,21	10,8	0,65	PT 1/4"	10	3	79
RRI-2206/28	RRI	6,5	3/8" x 24 UNF	R	2.800	0,26	7,6	0,60	PT 1/4"	10	0,4	84
RRI-2206/40	RRI	6,5	3/8" x 24 UNF	R	4.000	0,26	7,6	0,60	PT 1/4"	10	0,6	86
YRD-6NBK	YOKOTA	6-8	3/8" x 24 UNF	R	2.800	0,33	8,3	0,90	PT 1/4"	10	3	76
YRD-8NBK	YOKOTA	8-10	3/8" x 24 UNF	R	1.900	0,38	10,0	1,30	PT 1/4"	10	3	75
MD-10L	TOKU	10	3/8" x 24 UNF	R	2.300	0,30	8,0	0,90	PT 1/4"	10	1,3	73
RR-10DP ³⁾	RRA	10	3/8" x 24 UNF	L/R	1.800	0,35	8,0	1,1	PT 1/4"	10	4	83
YRD-10NBK	YOKOTA	10-13	1/2" x 20 UNF	R	1.000	0,44	10,0	1,50	PT 1/4"	10	1,3	80
YRD-13NBK	YOKOTA	13	1/2" x 20 UNF	R	700	0,50	13,3	1,6	PT 1/4"	10	0,8	79
RR-13DP ³⁾	RRA	13	3/8" x 24 UNF	L/R	800	0,35	8,0	1,3	PT 1/4"	10	4	83
RRI-2116P ¹⁾	RRI	16	1/2" x 20 UNF	R	950 ²⁾	0,50	11,0	2,4	PT 1/4"	10	1,8	82

¹⁾ Supplied with exhaust hose / ²⁾ Min. 650 p/min - Max. 950 p/min. / ³⁾ Gears with needle bearings

Angle model

MD-3312B	TOKU	10	3/8" x 24 UNF	L/R	1.900	0,38	6,0	0,91	PT 1/4"	6,5	2,3	77
----------	------	----	---------------	-----	-------	------	-----	------	---------	-----	-----	----

Straight model

10RDS-2500	RRA	10	3/8" x 24 UNF	R	2.500	0,37	3,5	1,1	PT 1/4"	6,5	0,4	79
10RDS-4000	RRA	10	3/8" x 24 UNF	R	4.000	0,37	3,5	1,1	PT 1/4"	6,5	0,4	79

Charger & Li-ion battery



Charger



Li-ion-battery

Type	Order number
Charger (40 Min.)	B84192B
Li-ion-battery 18V 1,5 Ah	BB180C-315
Power cord	E86B-VD European style E86B-UK UK style

Programmer with USB connection

- Easy to set the tool speed:
 - High speed for metallic assemblies
 - Medium speed for plastic assemblies
 - Low speed for special assemblies
- Total count memory function
- Operation count memory function
- Tool identification number
- Sound level of beeper



Type	Order number
Programmer	B745C180B

Type	Volt. V	Drive size in	Screw size mm	Torque range Nm	Free speed RPM	Weight w/o Batt. kg
RRI-BS3	18	1/4" Hex	M3-M4	0,8-3	500-1.550	0,95
RRI-BS6	18	1/4" Hex	M3-M5	1-6	300-900	0,95
RRI-BS9	18	1/4" Hex	M3-M5	1,5-9	300-700	0,95
RRI-BS12	18	1/4" Hex	M4-M6	2-12	250-550	0,95

DIMENSIONS

Type	A mm	B mm	C mm
RR-10DP	185	165	-
RR-13DP	218	165	-
10RDS-2500	250	-	22
10RDS-4000	250	-	25
MD-10L	162	140	22
MD-3312B	205	93	20
RRI-2006	192	138	14
RRI-2206/28	128	116	14
RRI-2206/40	128	116	14
RRI-2116P	270	168	28
YRD-6NBK	151	140	21
YRD-8NBK	176	150	25
YRD-10NBK	209	150	25
YRD-13NBK	218	145	25

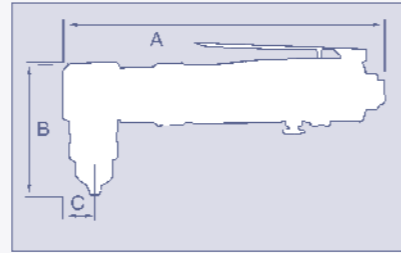
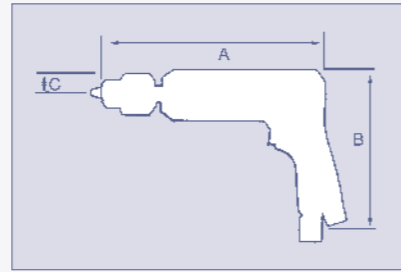

For matrix, casting and press-moulding



YDP-13



YDP-20

The Yokota dowel pin puller is used in matrix, casting and press-moulding industries, for setting and removing dowel pins in moulds or presses. The dowel pin puller is an easily operated air tool and can simplify the pulling or hammering operation of the threaded dowel pins, saving time and improving working efficiency.

Type	Brand	Capacity pin mm	Stroke mm	Blows min ⁻¹	Air cons. l/s	Weight kg	Inlet-thread	Hose diameter mm
YDP-13	YOKOTA	13	30 x 25	5.000	3,3	1,35	PT 1/4"	6,5
YDP-20	YOKOTA	20	36 x 33	2.700	4,3	2,10	PT 1/4"	6,5

PULLING & HAMMERING OPERATION

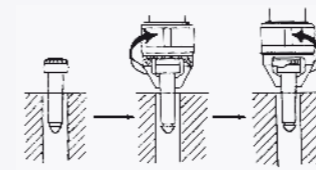

Pulling operation

1. Screw hanger bolt to threaded pin.
2. Fit dowel pin to guide hole.
3. Lock hanger bolt.
4. Operate the tool to pull up the pin.

Hammering operation

1. Screw hanger bolt to threaded pin.
2. Fit dowel pin to guide hole.
3. Operate the tool to hammer dowel pin.
4. Start the tool.

ACCESSORIES

Drill chucks

Type	Order number
MD-10L	* 10MM-3/8 x 24NF
MD-3312B	* 10MM-3/8 x 24NF
RRI-2206/28	* 6MM-3/8 x 24NF
RRI-2206/40	* 6MM-3/8 x 24NF
RRI-2206/40	* 6MM-3/8 x 24NF
RRI-2116P	* BHP-16 1/2 x 20NF
10RDS-4000	* 10MM-3/8 x 24NF

* Supplied as standard

Quickchange drill chucks

Type	Order number
RR-10DP	* 10035-14
10RDS-2500	* 10035-14
YRD-6NBK	* BHS-10MM
YRD-8NBK	* BHS-10MM
YRD-10NBK	* BHS-13MM
YRD-13NBK	* BHS-13MM
RR-13DP	* 10033-14

* Supplied as standard

Side handles

Type	Order number
RR-13DP	* 822340 + 75-725139-0001S
RRI-2116P	* 2116-061-99

* Supplied as standard

Keys for drill chucks

Type	Order number
MD-10L	* 90180
MD-3312B	* 90180
RRI-2116P	* 90200
RRI-2206/28	* 90160
RRI-2206/40	* 90160

* Supplied as standard

ACCESSORIES

Hanger bolts for YDP-13	Order number
M8 x 29L	6502-0022-00-01
M6 x 23L	6502-0022-00-02
M5 x 21L	6502-0022-00-03
M4 x 21L	6502-0022-00-04
M8 x 50L	6502-0022-00-05
M8 x 100L	6502-0022-00-06
M8 x 150L	6502-0022-00-07
M8 x 200L	6502-0022-00-08
M6 x 50L*	6502-0022-00-09
M6 x 100L	6502-0022-00-10
M6 x 150L	6502-0022-00-11
M6 x 200L	6502-0022-00-12
M5 x 50L*	6502-0022-00-13
M5 x 100L	6502-0022-00-14
M5 x 150L	6502-0022-00-15
M5 x 200L	6502-0022-00-16
M4 x 50L*	6502-0022-00-17
M4 x 100L	6502-0022-00-18
M4 x 150L	6502-0022-00-19
M4 x 200L	6502-0022-00-20

Hanger bolts for YDP-20	Order number
M12 x 36L	6503-0022-00-01
M10 x 33L	6503-0022-00-02
M8 x 32L	6503-0022-00-03
M8 x 100L	6503-0022-00-04
M8 x 150L	6503-0022-00-05
M8 x 200L	6503-0022-00-06
M10 x 100L	6503-0022-00-07
M10 x 150L	6503-0022-00-08
M10 x 200L	6503-0022-00-09
M12 x 100L	6503-0022-00-10
M12 x 150L	6503-0022-00-11
M12 x 200L	6503-0022-00-12
M8 x 50L*	6503-0022-00-13
M10 x 50L*	6503-0022-00-14
M12 x 50L*	6503-0022-00-15
M6 x 50L	6503-0022-00-16

DIMENSIONS

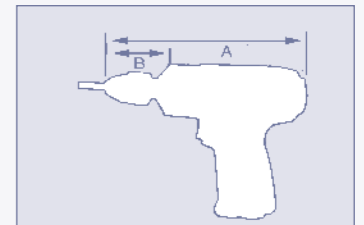

Type	A mm	B mm
YDP-13	162	75
YDP-20	195	82

Grinders

Angle models



Type	Brand	Wheel size mm	RPM	Power kW	Collet chuck mm	Air-cons. l/s	Weight kg	Inlet-thread	Hose diameter mm	Vibration m/s ²	Noise level dB(A)
RRG-2090	RRA	35	20.000	0,23	6	4,0	0,56	PT 1/4"	6,5	2,4	84
RRI-3506	RRI	40	18.000	0,22	6	4,9	0,55	PT 1/4"	6,5	1	80
MG-7236B	TOKU	40	20.000	0,20	6	5,0	0,45	PT 1/4"	6,5	2	85

Air turbine grinder



Type	Brand	Wheel-size mm	RPM	Power kW	Collet chuck mm	Air-cons. l/s	Weight kg	Inlet-thread	Hose diameter mm	Vibration m/s ²	Noise level dB(A)
RRI-T1565	RRI	9	65.000	0,15	3	3,7	0,135	PT 1/4"	6,5	<2,5	75
RRI-T4065	RRI	9	65.000	0,4	3	5,6	0,2	PT 1/4"	6,5	<2,5	75
RRI-T1550	RRI	20	50.000	0,15	3	3,7	0,135	PT 1/4"	6,5	<2,5	75
RRI-T3750	RRI	20	50.000	0,37	3	5,6	0,2	PT 1/4"	6,5	<2,5	75
RRI-T3340	RRI	20	40.000	0,33	6	5,6	0,4	PT 1/4"	6,5	<2,5	75
RRI-T1135	RRI	20	35.000	0,11	3	3,7	0,135	PT 1/4"	6,5	<2,5	75
RRI-T3335	RRI	20	35.000	0,33	3	5,6	0,2	PT 1/4"	6,5	<2,5	75
RRI-T5625	RRI	35	25.000	0,56	6	5,6	1,0	PT 1/4"	6,5	<2,5	75

Die grinder set



RRI-3007 / RRI-3006

Type	Brand	Wheel size mm	RPM	Power kW	Collet chuck mm	Air-cons. l/s	Weight kg	Inlet-thread	Hose diameter mm	Vibration m/s ²	Noise level dB(A)
RRI-3007	RRI	9	70.000	0,08	3	1,6	0,35	PT 1/4"	6,5	1,2	77
RRI-3006	RRI	12	58.000	0,10	3	1,6	0,35	PT 1/4"	6,5	0,8	80

Grinders

Die grinders



Type	Brand	Wheel size mm	RPM	Power kW	Collet chuck mm	Air-cons. l/s	Weight kg	Inlet-thread	Hose diameter mm	Vibration m/s ²	Noise level dB(A)
RRI-34100	RRI	6	100.000	0,09	3	3,3	0,20	PT 1/4"	6,5	<2,5	73
RRI-3445	RRI	20	45.000	0,30	3 / 6	7,5	0,40	PT 1/4"	10	2,4	79
MG-OA	YOKOTA	20	25.000	0,30	6	6,2	0,45	PT 1/4"	6,5	5	78
RRI-3430	RRI	20	30.000	0,23	3 / 6	7,5	0,40	PT 1/4"	10	2,2	81
MG-7206B	TOKU	25	23.000	0,38	6	5,0	0,56	PT 1/4"	6,5	2,3	81
MG-OC	YOKOTA	25	33.000	0,13	6	3,0	0,39	PT 1/4"	6,5	3	78
RRG-200RE	RRA	35	25.000	0,25	6	4,0	0,56	PT 1/4"	6,5	2,5	83
RRG-200REL	RRA	35	25.000	0,25	6	4,0	0,86	PT 1/4"	6,5	1,5	83
RRG-500RE	RRA	35	20.000	0,37	6	4,6	0,7	PT 1/4"	6,5	1,68	79
RRG-500REL	RRA	35	20.000	0,37	6	4,6	1,4	PT 1/4"	6,5	1,68	79
RRI-3425	RRI	35	25.000	0,50	3 / 6	12,3	0,8	PT 1/4"	10	2	80,2
RRI-3425L	RRI	35	20.000	0,50	3 / 6	12,3	0,8	PT 1/4"	10	2,5	80,2
RRI-3425EL	RRI	35	20.000	0,50	3 / 6	12,3	0,95	PT 1/4"	10	2,5	80,6
MG-1B	TOKU	45	18.000	0,28	6	8,0	0,55	PT 1/4"	10	1,3	77
RRI-3407	RRI	35	7.000	0,70	6	4,0	1,15	PT 1/4"	6,5	<2,5	84
RRG-202T*	RRA	80	2.500	0,3	7/16" HEX	4,0	1,1	PT 1/4"	6,5	2	84

* Tire buffer / Shaftlength: RRG-200REL: 75 mm / RRG-500REL: 150 mm / RRI-3425: 130 mm / RRI-3425L: 215 mm / RRI-3425EL: 240 mm

Note: MG-7206B and RRG-200RE are also available in set (including assortment abrasives).

Collet chucks for die grinders are supplied with the tool.

For collet chuck's and nuts see p. 41/42.

Grinders

Straight models



Type	Brand	Wheel size mm	RPM	Power kW	Spindle	Air cons. l/s	Weight kg	Inlet-thread	Hose diameter mm	Vibration m/s ²	Noise level dB(A)
GS-2EFS*	YOKOTA	65 x 13 x 9,5	14.000	0,45	3/8" x 16	10,0	1,3	PT 1/4"	10	3	84
TSG-3L	TOKU	75 x 13 x 9,5	11.500	0,53	3/8"	8,3	1,6	PT 3/8"	10	0,8	73
TSG-4L	TOKU	100 x 19 x 15,9	9.000	1,05	5/8"	16,6	3,0	PT 3/8"	13	1,1	83
TSG-5L	TOKU	125 x 19 x 12,7	7.600	1,05	1/2"	16,6	3,0	PT 3/8"	13	1,5	79
TSG-6L	TOKU	150 x 25 x 15,9	6.000	1,58	5/8"	20,0	4,2	PT 3/8"	13	0,8	80

*silenced

Vertical grinders



Type	Brand	Wheel size mm	RPM	Power kW	Spindle	Air cons. l/s	Weight kg	Inlet-thread	Hose diameter mm	Vibration m/s ²	Noise level dB(A)
7VC-6500FS*	YOKOTA	230 x 6 x 22	6.500	1,74	5/8"	23,0	4,2	PT 3/8"	13	3	82
7VC-8500FS*	YOKOTA	180 x 6 x 22	8.500	1,74	5/8"	23,0	4,1	PT 3/8"	13	2,1	83

*silenced

All vertical and straight grinders have a governor wheel for regulating the right speed of the grinding wheel. This reduces the risk of overspeeding and assures the best material removal.

Both Yokota and Toku straight grinders have double rows of bearings for long lifetime.

Grinders

Angle models



Type	Brand	Wheel size mm	RPM	Power kW	Spindle (Whitworth) mm	Air cons. l/s	Weight kg	Inlet-thread	Hose diameter mm	Vibration m/s ²	Noise level dB(A)
RRG-1040AL	RRA	100 x 1 x 9,6	14.000	0,76	M6	11,0	1,7	PT 1/4"	10	2,5	83
G-40SRF	YOKOTA	100 x 6 x 16	13.000	0,39	M8 x 1,25	7,5	0,90	PT 1/4"	10	6,6	79
RRG-2034*	RRA	100 x 6 x 16	10.000	0,45	M10	11,0	1,55	PT 1/4"	10	2,3	83
TAG-40FLH*	TOKU	100 x 6 x 16	13.000	0,55	M8	10,8	1,70	PT 3/8"	10	2,6	83
RRG-2044*	RRA	115 x 6 x 22	10.000	0,45	M14x2	11,0	1,60	PT 1/4"	10	2,4	83
G-40EF*	YOKOTA	115 x 6 x 22	13.000	0,60	7/16"	10,8	1,40	PT 1/4"	10	6,6	79
TAG-45MLH*	TOKU	115 x 6 x 22	13.000	0,67	M14x2	10,8	1,80	PT 3/8"	10	2,7	83
RRG-2055*	RRA	125 x 6 x 22	10.000	0,45	M14x2	11,0	1,60	PT 1/4"	10	2,4	83
G-50EF*	YOKOTA	125 x 6 x 22	12.000	0,60	7/16"	10,8	1,50	PT 1/4"	10	4	77
G-50RF*	YOKOTA	125 x 6 x 22	12.000	0,60	7/16"	10,8	1,40	PT 1/4"	10	4	77
TAG-50MLH*	TOKU	125 x 6 x 22	12.000	0,67	M14x2	10,8	1,80	PT 3/8"	10	2,7	83
RRI-G50*	RRI	125 x 6 x 22	12.000	1,25	M14x2	22	1,8	PT 1/4"	13	<2,5	83
RRI-GT50F*	RRI	125 x 6 x 22	12.200	2,2	M14x2	30	1,8	PT 1/2"	13	<2,5	79
G-70EF*	YOKOTA	180 x 6 x 22	8.500	1,12	5/8"	16,7	2,90	PT 3/8"	13	2,3	82
TAG-700QJL*	TOKU	180 x 6 x 22	8.500	1,10	-	16,6	3,10	PT 3/8"	13	2,6	82
TAG-900QJL*	TOKU	230 x 6 x 22	6.500	1,10	-	16,6	3,10	PT 3/8"	13	3,6	82

* Vibration reduced side-handle.

All angle grinders are supplied with regulator (for optimal safety and the correct RPM for best material removal).

RRG-2034, RRR-2044 and RRG-2055 are supplied with flanges for wheel thickness of 0,8 - 6 mm.

Flanges for cup wheels and a tool service set for mounting the flanges are supplied with all grinders.

TAG-45MLH and TAG-50MLH are supplied with flanges for wheel thickness of 1,6 - 6 mm and have a spindle lock.

All angle grinders are supplied with an vibration reduced side handle, with exception of the models HS-4G and G-40SRF.

For model G-70EF, flanges for flat wheels have to be ordered separately.

Type	A mm	B mm	C mm	D mm	E mm
7VC-6500FS	195	180	180	160	-
7VC-8500FS	195	180	180	165	-
G-40EF	299	88	29	50	-
G-40RF	200	88	29	50	-
G-40SRF	196	65	25	40	-
G-50EF	299	88	29	50	-
G-50RF	200	88	29	50	-
G-70EF	341	107	37	60	-
GS-2EFS	350	51	-	-	-
MG-OA	170	29	15	55	62
MG-OC	197	33	20	50	56
MG-1B	162	43	19	46	48
MG-7206B	164	40	-	-	-
MG-7236B	124	72	-	32	-
RRG-200RE	162	40	18	30	34
RRG-200REL	258	40	18	116	135
RRG-202T	233	44	31	52	92
RRG-500RE	190	45	22	30	-
RRG-500REL	350	45	22	180	190
RRG-1040AL	377	42	22	45	-
RRG-2090	167	75	-	42	-
RRG-2034	215	95	25	50	-
RRG-2044	215	95	25	50	-
RRG-2055	215	95	25	50	-
RRI-3006	151	16	10	-	-
RRI-3007	151	16	10	-	-
RRI-3407	280	45	28	38	80
RRI-3425	215	40	12	30	43
RRI-3425L	310	40	12	130	130
RRI-3425EL	390	40	12	215	215

Type	A mm	B mm	C mm	D mm	E mm
RRI-3430	190	34	14	16	22
RRI-3445	190	34	14	16	22
RRI-34100	140	29	10	15	21
RRI-3506	150	80	-	40	-
RRI-G50	255	55	32	45	-
RRI-GT50F	295	89,5	-	-	-
TAG-40FLH	267	85	33	50	-
TAG-45MLH	267	85	33	50	-
TAG-50MLH	267	85	33	50	-
TAG-700 QJL	307	103	36	62	-
TAG-900 QJL	307	103	36	62	-
TSG-3L	365	51	-	-	-
TSG-4L	460	65	-	-	-
TSG-5L	460	65	-	-	-
TSG-6L	490	80	-	-	-

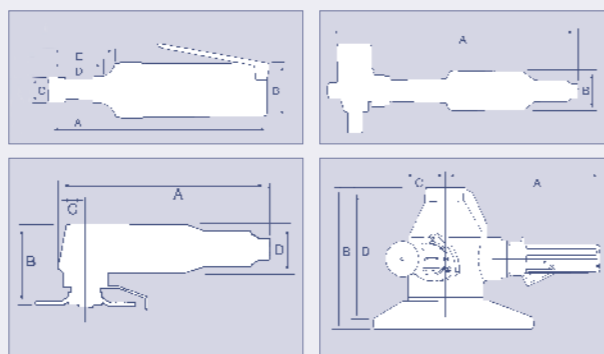

Type	A mm	B mm	C mm	D mm
RRI-T1565	156	31	13	120
RRI-T4065	172	43	13	134
RRI-T1550	156	31	13	120
RRI-T3750	172	43	13	134
RRI-T3340	196	43	15,5	145
RRI-T1135	156	31	13	120
RRI-T3335	172	43	13	134
RRI-T5625	295	67	15,5	150

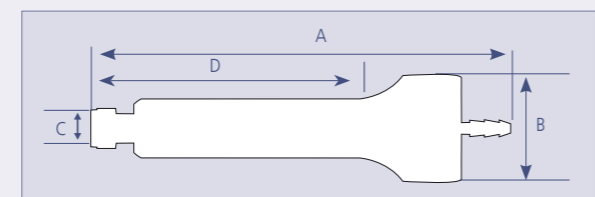

All angle grinders are equipped with flanges to adapt flat and depressed grinding wheels.

Rubber pads



TAG-45MLH TAG-50MLH	9310-3008-00-00	Disc 100 x 22 mm Paper 115 x 22 mm
G-40EF/RF	9310-3003-00-00	* Disc 110 x 16 mm Paper 115 x 22 mm
G-50EF/RF	9310-3004-00-00	* Disc 120 x 16 mm Paper 125 x 22 mm
G-70EF 7VC-6500FS 7VC-8500FS	9310-3006-00-00	* Disc 175 x 22 mm Paper 180 x 22 mm

Accessories for rubber pads

G-40EF/RF G-50EF/RF	1120-0658-00-0	* Outer flange
G-40RF/EF G-50RF/EF	1120-0655-00-01	* Outer wheel screw
G-70EF 7VC-6500FS 7VC-8500FS	1508-0653-01-02	* Innenflansch
G-70EF 7VC-6500FS 7VC-8500FS	1508-0654-05-05	Inner flange

* These products are supplied in sets with rubber pads and flanges.

Standard flanges and outer wheel screws



G-40EF/RF	9310-3003-00-99	Disc 110 x 16 mm Paper 115 x 22 mm
G-50EF/RF	9310-3004-00-99	Disc 120 x 16 mm Paper 125 x 22 mm
G-70EF 7VC-6500FS 7VC-8500FS	9310-3006-00-99	Disc 175 x 22 mm Paper 180 x 22 mm

Accessories for flat cut-off discs



G-70EF 7VC-6500FS 7VC-8500FS	1508-0653-00-03	Inner flange
G-70EF 7VC-6500FS 7VC-8500FS	1508-0654-00-02	Outer flange

Standard flanges and outer wheel screws



TAG-40FLH	42-05-77-171 13-17-08-020	* Outer flange * Outer wheel screw
TAG-45MLH TAG-50MLH	42-05-80-H00	* Outer flange
TAG-700 QJL TAG-900 QJL	2700-040-00 2700-041-00	* Outer flange * Outer wheel screw
G-40SRF	1105-0654-02-02 1105-0656-02-00	* Outer flange * Outer wheel screw
G-70EF 7VC-6500/8500	1422-0653-00-99 1508-0654-00-01 1508-0655-00-00	* Inner flange * Outer flange * Outer wheel screw
RRG-2034 RRG-2044 RRG-2055	5D-619238 5D-619240	* Inner flange * Outer flange

* Supplied as standard

M14x2 Quick nut



RRG-2044 RRG-2055 RRI-G50 RRI-GT50 TAG-45MLH TAG-50MLH	QN-M14
---	--------

Accessories for cup stones / cup brushes



7VC-6500FS 7VC-8500FS	1508-0653-01-02	Inner flange
7VC-6500FS 7VC-8500FS	8100-4003-00-01	Angle spanner
7VC-6500FS 7VC-8500FS	8100-1005-00-00	Pin spanner
7VC-6500FS 7VC-8500FS	8100-5001-00-00	Double key spanner

Accessories for grinding wheels



G-40/G-50 EF/RF	1117-0653-00-01	Inner flange 16 mm
G-40/G-50 EF/RF	1117-0654-00-01	Outer flange 16 mm
G-40/G-50 EF/RF	1117-0653-00-02	* Inner flange 22 mm
G-40/G-50 EF/RF	1117-0654-00-02	* Outer flange 22 mm
G-40/G-50 EF/RF	1126-0655-00-00	* Outer wheel screw for 22 mm flange

* Supplied as standard

Collet chucks



MG-7206B	NVK-A10	-	3 mm
GS-2EFS / TSG-3L	1104-0661-01-99	-	6 mm
RRG-200RE(L) RRG-500RE(L)	51224	-	6 mm
MG-OC	1011-0661-00-00	*	6 mm
MG-OA	1013-0661-01-99	*	6 mm
MG-1B	42-04-90-K10	*	6 mm
MG-7206B	EG7206033	*	6 mm
MG-7236B	3003-035-00	*	6 mm
RRI-3407	315073	-	8 mm

* Supplied as standard

Adapters



MG-OA MG-OC MG-1B MG-7206B MG-7236B RRI-3325(L/EL) RRG-200RE(L) RRG-500RE(L) RRI-T3340 RRI-T5625 RRI-3407	1001-0659-00-01	3 mm for 6 mm collet chuck
---	-----------------	-------------------------------

Tools for mounting grinding wheels



HS-4	8081-0021-00-00	*	Spanner H36
HS-4	8100-2001-00-00	*	Forked wrench
G-40 / G-50	8100-1003-00-00	*	Bar wrench
G-40 / G-50	8100-2001-00-00	*	Forked wrench
G-40 / G-50	8100-3001-00-00	*	L-wrench
G-70EF 7VC6500FS 7VC8500FS	8100-5002-00-00	*	Twin wrench
G-70EF 7VC6500FS 7VC8500FS	8081-0020-00-00	*	Spanner H32
TAG-40FLH	13-40-01-006	*	Hex wrench 6 mm
TAG-40FLH	42-05-71-G90	*	Wheel ring washer
TAG-40FLH TAG-45MLH TAG-50MLH	13-40-04-014	*	Combi spanner 14 x 19
TAG-45MLH TAG-50MLH	13-08-02-147	*	Socket bar
TAG-700QJL TAG-900QJL	8081-0022-00-00	*	Spanner H41
TAG-40FLH TAG-45MLH TAG-50MLH TAG-700QJL TAG-900QJL	9610-1010-00-00	*	Hex wrench H10
RRI-GT50F	828832	*	Forked wrench

* Supplied as standard

Exhaust hose/silencer kit



RRG-2034 RRG-2044 RRG-2055	5D-619249
----------------------------------	-----------

Red Rooster ATLUB oil

Red Rooster orbital sanders may be used with "oil free" air. In case of "oil free" air, it speaks for itself that the air quality (dry, clean) is of significant importance for the lifetime of the air motor. To achieve the optimal lifetime and performance of the air motor it is advised to lubricate the air (Red Rooster Atlub oil).



HS-4



MS-4125B



RRR-5125-2SV
RRI-5125-5SV
RRI-6150-2SV
RRI-6150-5SV



RRI-5125-2CV RRI-6150-2CV
RRI-5125-5CV RRI-6150-5CV



RRI-5125-2NV RRI-6150-2NV
RRI-5125-5NV RRI-6150-5NV



RRI-T6250-5NV
RRI-T6250-5CV



RRB-280

Palm sanders

Type	Brand	Pad size mm	Stroke mm	RPM	Power kW	Spindle	Air cons. l/s	Weight kg	Inlet-thread	Hose diameter mm	Vibration m/s ²	Noise level dB(A)
HS-4	YOKOTA	127 x 22	-	12.000	0,5	7/16" x 20	9,2	1,1	PT 1/4"	10	2	79
MS-4125B	TOKU	125 x 22	-	20.000	0,5	7/16" UNF	8,3	1,0	PT 1/4"	10	2,3	90

Palm orbital sanders

Type	Brand	Pad size mm	Stroke mm	RPM	Power kW	Spindle	Air cons. l/s	Weight kg	Inlet-thread	Hose diameter mm	Vibration m/s ²	Noise level dB(A)
RRI-5125-2NV ¹	RRI	125	2,5	12.000	0,3	5/16" UNF	4,9	0,76	PT 1/4"	6,5	<2,5	73
RRI-5125-2CV ¹	RRI	125	2,5	12.000	0,3	5/16" UNF	4,9	0,76	PT 1/4"	6,5	<2,5	73
RRI-5125-2SV ¹	RRI	125	2,5	12.000	0,3	5/16" UNF	4,9	0,78	PT 1/4"	6,5	<2,5	73
RRI-5125-5NV ¹	RRI	125	5	12.000	0,3	5/16" UNF	4,9	0,76	PT 1/4"	6,5	<2,5	73
RRI-5125-5CV ¹	RRI	125	5	12.000	0,3	5/16" UNF	4,9	0,78	PT 1/4"	6,5	<2,5	73
RRI-5125-5SV ¹	RRI	125	5	12.000	0,3	5/16" UNF	4,9	0,78	PT 1/4"	6,5	<2,5	73
RRI-6150-2NV ¹	RRI	150	2,5	12.000	0,3	5/16" UNF	4,9	0,76	PT 1/4"	6,5	<2,5	73
RRI-6150-2CV ¹	RRI	150	2,5	12.000	0,3	5/16" UNF	4,9	0,78	PT 1/4"	6,5	<2,5	73
RRI-6150-2SV ¹	RRI	150	2,5	12.000	0,3	5/16" UNF	4,9	0,78	PT 1/4"	6,5	<2,5	73
RRI-6150-5NV ¹	RRI	150	5	12.000	0,3	5/16" UNF	4,9	0,76	PT 1/4"	6,5	<2,5	73
RRI-6150-5CV ¹	RRI	150	5	12.000	0,3	5/16" UNF	4,9	0,78	PT 1/4"	6,5	<2,5	73
RRI-6150-5SV ¹	RRI	150	5	12.000	0,3	5/16" UNF	4,9	0,78	PT 1/4"	6,5	<2,5	73
RRI-T6250-5NV ¹	RRI	150	5	12.000	0,3	5/16" UNF	4,9	1,0	PT 1/4"	6,5	3,65	73
RRI-T6250-5CV ¹	RRI	150	5	12.000	0,3	5/16" UNF	4,9	1,0	PT 1/4"	6,5	3,65	73

¹ Standard delivered with Hook & Loop. **NV** = No dust extraction / **CV** = For connection to central dust extraction / **SV** = Self created Vacuum for dust extraction

Wire brush sander

Type	Brand	Pad size mm	Stroke mm	RPM	Power kW	Spindle	Air cons. l/s	Weight kg	Inlet-thread	Hose diameter mm	Vibration m/s ²	Noise level dB(A)
RRB-280	RRI	80 ¹⁾	-	8.000	0,45	M14 x 2 ²⁾	9,6	1,5	PT 1/4"	10	9	80

¹⁾ Size wire brush (supplied without wire brushes) / ²⁾ Spindle stainless steel

DIMENSIONS

Type	A mm	B mm	C mm	D mm
HS-4	125	102	145	127
MS-4125B	150	110	-	-
RRB-280	225	85	28	50
RRG-3611	50	265	-	-
RRG-3617K	50	265	-	-
RRG-3621	60	420	-	-
RRG-3630	60	490	-	-
RRI-5125-2NV/5NV	163	104	-	-
RRI-6150-2NV/5NV	163	104	-	-
RRI-5125-2CV/5CV	213	104	-	-
RRI-6150-2CV/5CV	213	104	-	-
RRI-5125-2SV/5SV	213	104	-	-
RRI-6150-2SV/5SV	213	104	-	-
RRI-T6250-5NV/5CV	262	104	-	-
RRS-60323	116	150	-	-
RRS-60152	116	140	-	-
RRS-60152	116	140	-	-

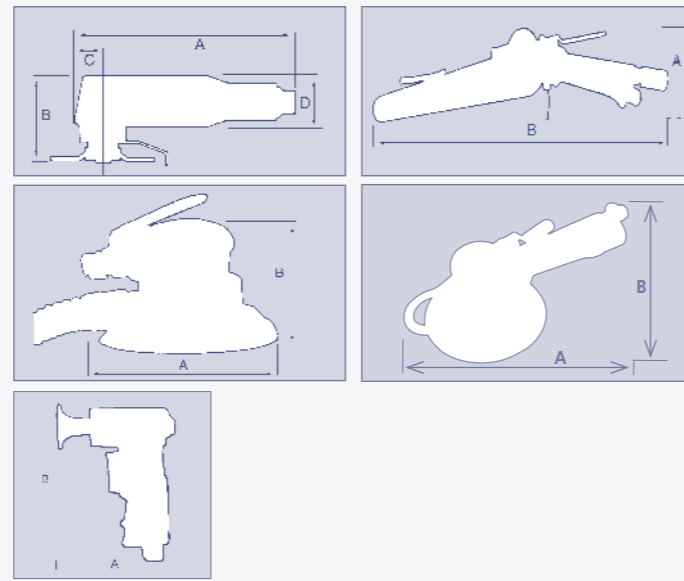

ACCESSORIES

Sanding pads	Order number	
HS-4	9350-1002-00-00	Fiber, 115 x 22 mm
RRS-6001 2K	600125-21	Roloc™-Pad, Ø 50 mm
RRS-60153	600127-31	Roloc™-Pad, Ø 75 mm
RRS-60323	6004-031-00	Velcro Sanding Pad, Ø 75 mm

Sanding pads	Order number	
RRI-5125-2NV RRI-5125-5NV	65-613342*	Hook & Loop-disc 125 mm
RRI-5125-2CV RRI-5125-5CV RRI-5125-2SV RRI-5125-5SV	65-6133C42*	Hook & Loop-disc 125 mm
RRI-6150-2NV RRI-6150-5NV RRI-T6250-5NV	610227V-61*	Hook & Loop-disc 150 mm
RRI-6150-2CV RRI-6150-5CV RRI-6150-2SV RRI-6150-5SV RRI-T6250-5CV	60-613142*	Hook & Loop-disc 150 mm

* Supplied as standard

Side handle	Order number
HS-4 G-40/50	1203-0013-0011*
TAG-40/45/50 TAG-700/900 RRG-2034/2044/2055	2400-046-11*
G-70	1407-0013-0011*

* Supplied as standard

Sanding belt for 6 mm sanding arm		
SSB60660	6 x 330 mm	Grain 60
SSB60680	6 x 330 mm	Grain 80
SSB606100	6 x 330 mm	Grain 100
SSB606120	6 x 330 mm	Grain 120
SSB606150	6 x 330 mm	Grain 150

Sanding belt for 10 mm sanding arm		
SSB61060	10 x 330 mm	Grain 60
SSB61080	10 x 330 mm	Grain 80
SSB610100	10 x 330 mm	Grain 100
SSB610120	10 x 330 mm	Grain 120
SSB610150	10 x 330 mm	Grain 150

Sanding belt for 20 mm sanding arm		
SSB62060	20 x 520 mm	Grain 60
SSB62080	20 x 520 mm	Grain 80
SSB620100	20 x 520 mm	Grain 100
SSB620120	20 x 520 mm	Grain 120
SSB620150	20 x 520 mm	Grain 150

Sanding belt for 30 mm sanding arm		
SSB63060	30 x 540 mm	Grain 60
SSB63080	30 x 540 mm	Grain 80
SSB630100	30 x 540 mm	Grain 100
SSB630120	30 x 540 mm	Grain 120
SSB630150	30 x 540 mm	Grain 150

Polishing pads	Order number	
RRS-60043K	SA-75543VC*	Yellow pad 3½"
RRS-60043K	SA-75653VC*	White pad 3½"
RRS-60043K	SA-77213*	Bonnet 3½"

* Supplied as standard

Belt sanders



RRG-3617K



RRG-3611



RRG-3621

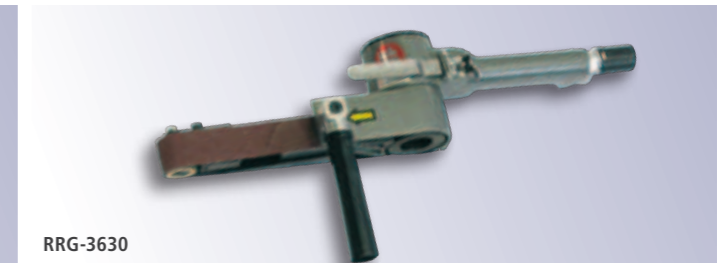

RRG-3630

Type	Brand	Belt size mm	RPM	Power kW	Air cons. l/s	Weight kg	Inlet-thread	Hose diameter mm	Vibration m/s ²	Noise level dB(A)
RRG-3617K	RRI	6/10 x 330	20.000	0,28	6,7	0,75	PT 1/4"	10	0,6	80
RRG-3611	RRI	10 x 330	20.000	0,28	6,7	0,75	PT 1/4"	10	0,6	80
RRG-3621	RRI	20 x 520	18.000	0,34	8,7	1,40	PT 1/4"	10	2,5	79
RRG-3630	RRI	30 x 540	12.000	0,52	10,3	2,20	PT 1/4"	10	2	79

The RRG-3617K is the same as model RRG-3611 however supplied as set. This set contains a sanding arm 6 x 330 mm and a sanding arm 10 x 330 mm (1 tool, 2 applications).

The Red Rooster belt sanders are suitable for nearly all materials, e.g. steel, aluminium, plastics and wood and for use as a de-burring method in difficult access applications. All belt sanders are executed with safety handle and adjustable silencer.

Mini sanders



RRS-60152



RRS-60153



RRS-60323

Type	Brand	Pad size mm	RPM	Power kW	Air cons. l/s	Weight kg	Inlet-thread	Hose diameter mm	Vibration m/s ²	Noise level dB(A)
RRS-60152 ¹⁾	RRA	50	15.000	0,3	4,9	0,54	PT 1/4"	10	0,74	80
RRS-60153 ²⁾	RRA	75	15.000	0,3	4,9	0,54	PT 1/4"	10	0,74	80
RRS-60323 ³⁾	RRA	75	3.200	0,3	4,9	0,75	PT 1/4"	10	0,74	80

¹⁾ RRS-60152 = mini sander Ø50 mm (Roloc™-Pad)

²⁾ RRS-60153 = mini sander Ø75 mm (Roloc™-Pad)

³⁾ RRS-60323 = mini polisher Ø75 mm (Velcro Pad)

Hammers

SHANK SIZE

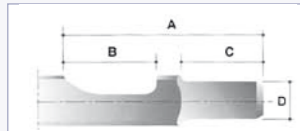

Type	A	B	C	D
TFC-200F	51	23	21	9,5

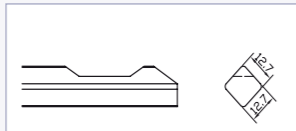

Type	A	B	C
F-25	16	12,7	28
RR-0315	16	12,7	28
TFC-257H	13	12,7	27

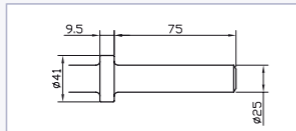

Type	A	B
RRI-4596R	75	25
RRI-4612R VL	75	25

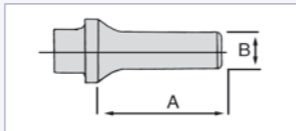

Type	A	B
RRH-4210	40	10,2
BRH-6	40	10,2

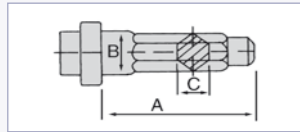

Type	A	B	C
RRH-4210K	50	12,5	10,5
RRH-2000	40	12,7	11

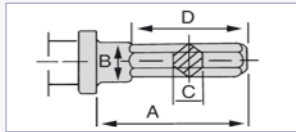

Type	A	B	C
AA-OBR(H)	53	15	12,7

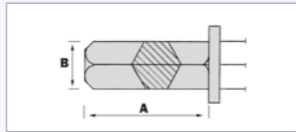

Type	A	B
RRI-4596/1	82	22
TCD-20	82	22
AA-1.3BR(H)19x50	50	19
THA-2BRH 19x50	50	19
THA-3BRH 19x50	50	19
THA-4BRH 19x50	50	19
RRI-4612K VL	82	22
AA-3BR(H) 19x50	50	19

Hammers



Type	Brand	Shank size mm	Bore diameter mm	Stroke mm	Blows p/min	J/Blow	Air cons. l/s	Weight kg	Inlet thread	Hose diameter mm	Vibration m/s ²	Noise level dB(A)
RRH-2000	RRA	○ 11 x ○ 12,7 x 40	17,4	42	5.000	4,5	8,4	1,5	PT 1/4"	10	8	88
TFC-200F	TOKU	□ 12,7	20	10	12.000	1,5	4,1	1,1	PT 1/4"	6,5	14,3	91
TFC-257H	TOKU	□ 12,7	25	34	4.000	7,9	6,7	1,73	PT 1/4"	10	14	92
F-25	YOKOTA	□ 12,7 x 16 x 28	25	22	4.000	5,1	6,0	1,8	PT 1/4"	6,5	12	91
RR-0315	RRA	□ 12,7 x 16 x 28	25	32	4.000	7,4	3,0	2,6	PT 1/4"	6,5	9,4	93
BRH-6	YOKOTA	○ 10,2 x 40	20	60	3.500	9	6,6	1,4	PT 1/4"	10	17	95
RRH-4210	RRA	○ 10,2 x 40	19	50	3.500	6,7	4,0	1,5	PT 1/4"	6,5	8	90
RRH-4210K	RRA	○ 10,5 x ○ 12,5 x 50	19	50	3.500	6,7	4,0	1,5	PT 1/4"	6,5	8	90
AA-OBR(H)	TOKU	○ 12,7 x ○ 15 x 53	20	50	3.600	7,5	5,8	2,6	PT 3/8"	6,5	12	89
AA-1.3BR(H)19x50 ¹⁾	TOKU	○ 19 x 50	24	58	2.800	12,7	7,5	4,5	PT 3/8"	10	10	93
THA-2BRH19x50	TOKU	○ 19 x 50	28,5	51	2.300	15,7	14,2	6,8	PT 3/8"	13	11,6	93
THA-3BRH19x50	TOKU	○ 19 x 50	28,5	64	2.200	19,9	15	7,2	PT 3/8"	13	8	93
THA-4BRH19x50	TOKU	○ 19 x 50	28,5	102	1.800	31,8	15,8	7,8	PT 3/8"	13	11,6	93
RRI-4596/1	RRI	○ 22 x 82	34	114	1.590	51,6	15,0	10,6	PT 3/4"	13	16	101
RRI-4596R	RRI	○ 25 x 75	34	114	1.590	51,6	15,0	10,6	PT 3/4"	13	16	101
RRI-4612K VL ²⁾	RRI	○ 22 x 82	35	170	1.290	81,2	16,6	12	PT 3/4"	13	3,8	105
RRI-4612R VL ²⁾	RRI	○ 25 x 75	35	170	1.290	81,2	16,6	12	PT 3/4"	13	3,8	105
TCD-20	TOKU	○ 22 x 82	43	60	2.000	42,4	18,0	11,4	PT 1/2"	13	16	106

¹⁾ Also available with shank size ○ 17,5 mm / ²⁾ Vibration reduced breakhammers (means give a high force per blow and a very low vibration and low noise level)

HAMMER SET

RRH-4210KSET



RRH-4210SET

including:

- Hammer RRH-4210
- 4 chisels: flat chisel, wide chisel, moil point, muffler cutter

RRH-4210KSET

including:

- Hammer RRH-4210K
- 4 chisels: flat chisel, wide chisel, moil point, muffler cutter

Hammers

ACCESSORIES

Quickchange chisel retainer

BRH-6	PT-2311	
RRH-2000	PT-2311	

Rubber ring for chisel retainer

RRH-4210(K)	7421002	*
-------------	---------	---

* Supplied as standard

Open spring

AA-1.3B	63112	*
AA-3B	63112	*
BRH-6	6101-0822-00-03	*

* Supplied as standard

Closed spring

AA-1.3B	63112-A	*
AA-3B	63112-A	*
BRH-6	6101-0822-00-01	*

* Supplied as standard

Retainer spring

RRH-2000	10219 RRH-2000	*
RRH-4210(K)	7421001	*
RRH-4021/3	4221-600-00	*

* Supplied as standard

Rubber ring

AA-1.3BR(H)17.3	60311	
AA-1.3BR(H)17.5	60311-17.5	

DIMENSIONS

Typ	A mm	B mm
AA-OBR(H)	245	95
AA-1.3BR(H)	300	76
BRH-6	200	149
F-25	310	43
RR-0315	320	43
RRH-2000	165	140
RRH-4210	217	131
RRH-4210K	217	131
RRI-4596	480	118
RRI-4612K VL	645	120
RRI-4612R VL	645	120
TCD-20	520	100
TFC-200F	189	40
TFC-257H	330	43
TH-5S	425	250
THA-2BRH19x50	350	87
THA-3BRH19x50	422	87
THA-4BRH19x50	430	87
TJ-15	468	340
TJ-20	385	585
TPB-40	660	390
TPB-40SV	649	390
TPB-501SV	714	390
TPB-60	645	400

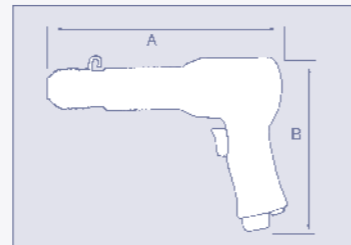
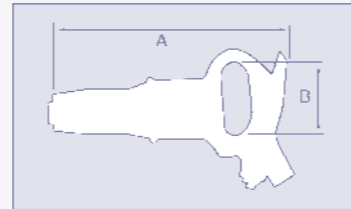
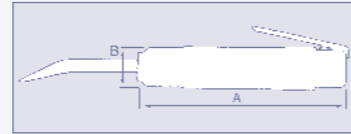

Breakers & rock drills



Paving breakers

Type	Brand	Shank size mm	Bore diameter mm	Stroke mm	Blows p/min	J/Blow	Air cons. l/s	Weight kg	Inlet-thread	Hose diameter mm	Vibration m/s ²	Noise level dB(A)
TPB-40	TOKU	○ 25 x 108	44	146	1.400	110	26	19	PT 3/4"	19	19,1	106
TPB-40SV ¹⁾	TOKU	○ 25 x 108	40	146	1.050	110	26	19,5	PT 3/4"	19	5,5	106
TPB-501SV ¹⁾	TOKU	○ 32 x 160	50	156	1.250	151	25	28,1	PT 3/4"	19	5,3	107
TPB-60	TOKU	○ 32 x 160	57	100	1.400	125	27	30	PT 3/4"	19	9,7	110

¹⁾ Vibration reduced

Rock drills

Type	Brand	Shank size mm	Bore diameter mm	Stroke mm	Blows p/min	RPM	J/Blow	Air cons l/sec	Weight kg	Inlet-thread	Hose diameter mm	Vibration m/s ²	Noise level dB(A)
TH-5S ¹⁾	TOKU	○19 x ○14,8 x 89	38	31	3.400	420	17	14	5,8	PT 3/8"	13	14	95
TJ-15SBS	TOKU	○ 22 x 82	54	45	2.450	250	44,7	26	17,4	PT 3/4"	19	30	99
TJ-15SV LBS ¹⁾	TOKU	○ 22 x 108	54	45	2.450	250	44,7	26	17,7	PT 3/4"	19	7,0	99
TJ-15SV SBS ¹⁾	TOKU	○ 22 x 82	54	45	2.450	250	44,7	26	17,4	PT 3/4"	19	7,0	99
TJ-20SV LBS ¹⁾	TOKU	○ 22 x 108	68	49	2.400	200	72	41	19	PT 3/4"	19	10,8	100
TJ-20SV SBS ¹⁾	TOKU	○ 22 x 82	68	49	2.400	200	72	41	19	PT 3/4"	19	10,8	100

¹⁾ Vibration reduced

SHANK SIZE

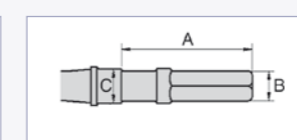
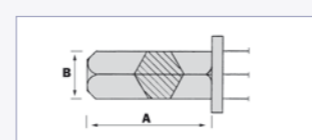

Type	A	B
TPB-40/40SV	108	25
TPB-50N/501SV	160	32
TPB-60	160	32
TJ-15LBS/SBS	108/82	22
TJ-20	108/82	22

Type	A	B	C
TH-5S	89	14,8	19

Chisels for air hammers

Shank size Ø 10,2 mm x 40 mm

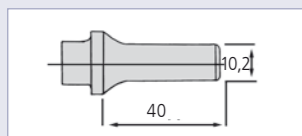

FOR HAMMERS
- Yokota BRH-6
- Red Rooster RRH-4210

Ordernumber	Description	L (mm) total	B (mm)
BE101002	Cutting chisel	122	20
BE101003	Sheet metal trimmer	135	16
BE101004	Panel cutter	131	15
BE101005	Muffler cutter	115	15
BE101006	Bushing splitter	132	12
BE101007	Spot-weld breaker bent	79	15
BE101008	Bushing driver	63	Ø 23
BE101009	Tapered punch	132	Ø 3
BE101010	Flat chisel	120	33
BE101011	Double edged cutter	110	22
BE101012	Shear bent	132	12
BE101015	Wide cutting bent	130	33
BE101016	Straight punch	120	Ø 12
BE101017	Spot-weld breaker	117	19
BE101018	Scraper	137	33
BE101019	Tail pipe cutter	119	29
BE101020	Concave scraping	130	34
BE101021	Wide cutting	129	44
BE101022	Diamond point	161	-
BE101024	Flat, bent	106	15
BE101025	Rivet cutter	109	23
BE101026	Round nose panel cutter	90	21
BE101027	Center punch chisel	106	Ø 9
BE101028	Pin punch	134	Ø 8

Shank size 10,5 mm Hex x Ø 12,5 mm x 50 mm

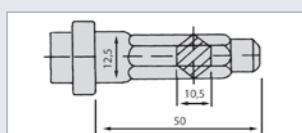

FOR HAMMERS
- Red Rooster RRH-4210K

Ordernumber	Description	L (mm) total	B (mm)
BE151002	Cutting chisel	122	20
BE151003	Sheet metal trimmer	135	16
BE151004	Panel cutter	131	15
BE151005	Muffler cutter	115	15
BE151007	Spot-weld breaker bent	79	15
BE151008	Bushing driver	63	Ø 23
BE151009	Tapered punch	132	Ø 3
BE151010	Flat chisel	120	33
BE151011	Double edged cutter	110	22
BE151012	Shear bent	132	12
BE151014	Double blade panel cutter	136	18
BE151015	Wide cutting, bent	130	33
BE151016	Straight punch	120	Ø 12
BE151017	Spot-weld breaker	117	19
BE151018	Scraper	137	33

continued: Shank size 10,5mm Hex x Ø 12,5mm x 50 mm

Ordernumber	Description	L (mm)	B (mm)
BE151019	Tail pipe cutter	119	29
BE151020	Concave scraping	130	34
BE151021	Wide cutting	129	44
BE151022	Diamond point	161	-
BE151024	Flat, bent	106	15
BE151025	Rivet cutter	109	23
BE151026	Round nose panel cutter	90	21
BE151027	Center punch chisel	106	Ø 9
BE151028	Pin punch	134	Ø 8
BE151031	Hollow gouge	155	17
BE152001	Slotting tool with carbide tip	155	30

Shank size 13,8 mm Hex x 75 mm

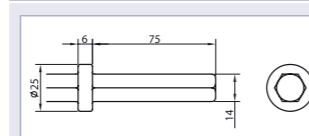

Ordernumber	Description	L (mm) under the collar	B (mm)
CB5100105/3	Moil point	200	-
CB5100102/3	Flat chisel	110	24
CB5100104/3	Flat chisel	180	24
CB5100103/3	Wide flat chisel	180	40
CB5100107/3S	Wide flat chisel	180	60
CB5100115/3	Wide flat chisel	180	100
CBMCOVAXS	Slotting tool with carbide tip	120	35
CBMCOVAXL	Slotting tool with carbide tip	140	35

Shank size 19 mm Hex x 50 mm

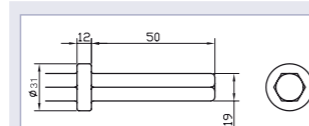

FOR HAMMERS
- Toku AA-1.3BR(H) 19x50
- Toku AA-3BR(H) 19x50
- Toku THA-serie

Ordernumber	Description	L (mm) under the collar	B (mm)
MP5	Moil point	250	-
MP5-350	Moil point	350	-
MP5-450	Moil point	450	-
NC5	Flat chisel	250	30
NC5-350	Flat chisel	340	30
NC5-450	Flat chisel	440	30
CB5	Wide flat chisel	250	60
CB5-G	Wide flat chisel, bent	250	60
CB19210	Wide flat chisel	210	95

Chisels for air hammers

Shank size 22 mm Hex x 82,5 mm

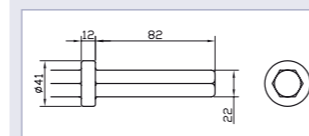

FOR HAMMERS
- Toku TCD-20
- Red Rooster RRI-4596/1
- Red Rooster RRI-4612K VL

Ordernumber	Description	L (mm) under the collar	B (mm)
MP4	Moil point	380	-
MP4-450	Moil point	450	-
MP4-1000	Moil point	1.000	-
MP4-1500	Moil point	1.500	-
MP4-2000	Moil point	2.000	-
NC4	Flat chisel	380	25
NC4-450	Flat chisel	450	25
NC4-1000	Flat chisel	1.000	25
NC4-1500	Flat chisel	1.500	25
NC4-2000	Flat chisel	2.000	25
CB4	Wide flat chisel	380	75
DC4	Digging chisel	400	80
AC4	Asphalt cutter	400	115

Shank size 25 mm Hex x 108 mm

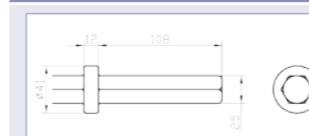

FOR HAMMERS
- Toku TPB-40
- Toku TPB-40SV

Ordernumber	Description	L (mm) under the collar	B (mm)
MP3	Moil point	380	-
MP3-450	Moil point	450	-
MP3-1000	Moil point	1.000	-
MP3-1500	Moil point	1.500	-
MP3-2000	Moil point	2.000	-
NC3	Flat chisel	380	25
NC3-450	Flat chisel	450	25
NC3-1000	Flat chisel	1.000	25
NC3-1500	Flat chisel	1.500	25
NC3-2000	Flat chisel	2.000	25
CB3	Wide flat chisel	360	75
DC3	Digging chisel	400	75
AC3	Asphalt cutter	400	125

Shank size 28 mm Hex x 160 mm

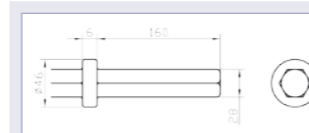

Ordernumber	Description	L (mm) under the collar	B (mm)
MP2A	Moil point	380	-
MP2	Moil point	450	-
NC2A	Flat chisel	380	35
NC2	Flat chisel	450	35
CB2A	Wide flat chisel	380	75
DC2	Digging chisel	400	75
CB5819	Asphalt cutter	350	125
AC2	Heavy asphalt cutter	270	115

Shank size 32 mm Hex x 160 mm

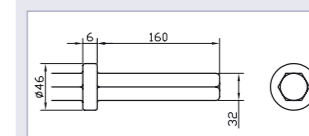

FOR HAMMERS
- Toku TPB-50N
- TokuTPB-501SV
- TPB-60

Ordernumber	Description	L (mm) under the collar	B (mm)
MP1A	Moil point	380	-
MP1	Moil point	450	-
MP1-900	Moil point	900	-
MP1-1000	Moil point	1.000	-
MP1-1500	Moil point	1.500	-
MP1-2000	Moil point	2.000	-
NC1A	Flat chisel	380	35
NC1	Flat chisel	450	35
CB1A	Wide flat chisel	380	75
DC1	Digging chisel	400	75
AC1	Heavy asphalt cutter	270	115
CB5019	Asphalt cutter	280	125
E1	Tagger plate shank	350	-
CB203001	Sheet board driver	-	57
CB203004	Sheet board driver	-	75
CB912904*	Tamper plate	-	-
CB912906**	Tamper plate	-	-

* Diameter 125 mm / ** Diameter 180 mm

Shank size Ø 25 mm x 75 mm, round collar 42 mm

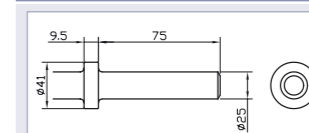

FOR HAMMERS
- Red Rooster RRI-4596/R
- Red Rooster RRI-4612R VL

Ordernumber	Description	L (mm) under the collar	B (mm)
B350MP	Moil point	350	-
B450MP	Moil point	450	-
B600MP	Moil point	600	-
B1000MP	Moil point	1.000	-
B1500MP	Moil point	1.500	-
B2000MP	Moil point	2.000	-
B350NC	Flat chisel	350	24
B450NC	Flat chisel	450	24
B600NC	Flat chisel	600	24
B1000NC	Flat chisel	1.000	24
B1500NC	Flat chisel	1.500	24
B2000NC	Flat chisel	2.000	24

Chisels for air hammers

Chisels for air hammers

Shank size 12,4 mm Hex / Ø 15 mm x 55 mm

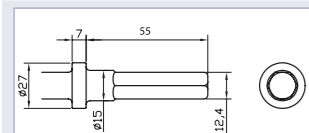

FOR HAMMERS
- BMH19

Ordernumber	Description	L (mm) under the collar	B (mm)
CB1911190	Flat chisel	190	23
CB1918200	Wide flat chisel	200	50
CB1917210	Wide flat chisel	210	95

Shank size 12,7 mm Hex / Ø 15 mm x 53 mm

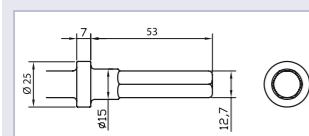

FOR HAMMERS
- Toku AA-OB
- Toku AA-OBR(H)

Ordernumber	Description	L (mm) total	B (mm)
BEAA-OB-01	Flat chisel	220	16
BEAA-OB-01 400mm	Flat chisel	400	16
BEAA-OB-02	Diamond point	20	-
BEAA-OB-02 400mm	Diamond point	400	-
BEAA-OB-03	Flat chisel	220	25
BEAA-OB-04	Flat chisel	220	49
BEAA-OB-05	Flat chisel	220	97
BEAA-OB-06	Flat chisel bent	220	50

Shank size 14,8 mm Hex / Ø 17,3 mm x 60 mm

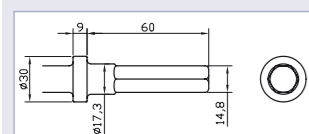

FOR HAMMERS
- Toku AA-1.3B, AA-3B (old series)

Ordernumber	Description	L (mm) under the collar	B (mm)
CB3210260	Moil point	260	-
CB3210450	Moil point	450	-
CB418	Round nose	210	-
CB420	Diamond point	160	-
CB3211260	Flat chisel	380	22
CB3211330	Flat chisel	253	20
CB424	Flat chisel	140	50
CB426	Flat chisel	137	38
CB3218200	Wide flat chisel	200	50
CB3218200G	Wide flat chisel, bent	200	60
CB3217210G	Wide flat chisel, bent	210	95

Shank size 14,8mm Hex / Ø 17,3mm x 60mm, oval collar

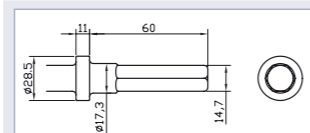

FOR HAMMERS
- Toku THH-2B H,
THH-3B H, THH-4B H (old series)

Ordernumber	Description	L (mm) under the collar	B (mm)
HS1-OC	Blank chisel	200	-
HS2-OC	Flat chisel	200	24
HS2-300-OC	Flat chisel	300	24
CB304	Flat chisel	158	24
CB304-12	Flat chisel	234	24
CB304-18	Flat chisel	386	24
CB324-24	Flat chisel	610	50
HS2-32-OC	Wide flat chisel	200	32
HS2-50-OC	Wide flat chisel	200	50
HS6-OC	Moil point	200	-
HS6-300-OC	Moil point	300	-

Shank size 17 mm 6 Hex / Ø 20 mm x 60 mm

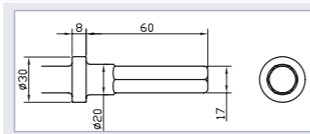

FOR HAMMERS
- Böhler MH

Ordernumber	Description	L (mm) under the collar	B (mm)
CB3310220	Moil point	220	-
CB3311220	Flat chisel	220	24
CB3318200	Wide flat chisel	260	50
CB3317210	Wide flat chisel	210	95

Shank size 27 mm x 80 mm, Collar 34 mm square

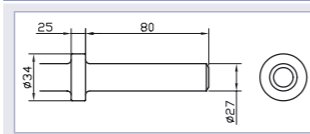

Ordernumber	Description	L (mm) under the collar	B (mm)
CB1362010045	Moil point	400	-
CB1362011045	Flat chisel	400	27
CB1362050036	Wide flat chisel	360	75
CB1362120040	Asphalt cutter	400	120

Shank size 11 mm Hex / Ø 12,7 mm x 40 mm

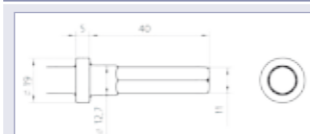

FOR HAMMER
- RRH-2000

Ordernumber	Description	L (mm) totale	B (mm)
CB51109165	Flat chisel	165	18
CB51112180	Wide flat chisel	180	33
CB51104190	Wide flat chisel, bent	190	33
CB51103185	Wide flat chisel	185	45
CB51115180	Moil point	180	-
CB51193180	Slotting tool with carbide tip	180	38

Shank size 13 mm square, with RRC recess

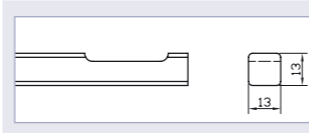

Ordernumber	Description	L (mm) total	B (mm)
CB3251	Flat chisel	178	19
CB3251-300	Flat chisel	300	19
CB3251-450	Flat chisel	450	19
CB3252	Wide flat chisel	155	38
CB3252-300	Wide flat chisel	300	38
CB3253	Wide flat chisel, bent	178	38
CBMCCORRC13.2	Slotting tool with carbide tip	150	38

Shank size 12,7 mm square, with recess

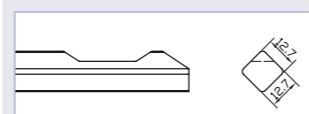

FOR HAMMERS
- Yokota F25
- Red Rooster RR-0315

Ordernumber	Description	L (mm) total	B (mm)
BE15/1B	Flat, bent	113	19
BE15/1F	Flat chisel	114	19
BE15/1G	Wide flat chisel, bent	113	35
BE15/1W	Wide flat chisel	118	35
8160-1002-00-00	Flat, bent	113	26
CBMCOF25-150	Slotting tool with carbide tip	150	35

Shank size 12,7 mm square, with recess



FOR HAMMER
- Toku TFC-200F

Ordernumber	Description	L (mm) total	B (mm)
CB40901180	Moil point	180	-
CB40902180	Flat chisel	180	19
CB40904180	Wide flat chisel, bent	180	35
CB40906180	Wide flat chisel, bent	180	50
CB40903180	Flat chisel	180	35

Shank size 12,7 mm square, with recess

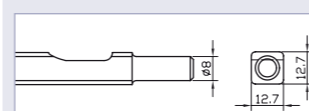

FOR HAMMER
- Cleco

Ordernumber	Description	L (mm) total	B (mm)
CB393-18	Wide flat chisel	450	35
CB390	Wide flat chisel	178	50
CB390-3	Wide flat chisel	178	75

Shank size 12,7 mm square, with recess

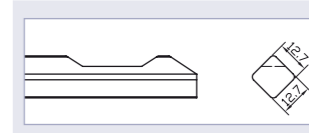

FOR HAMMER
- CP

Ordernumber	Description	L (mm) total	B (mm)
CB396	Flat chisel	178	19
CB396-300	Flat chisel	300	19
CB396-450	Flat chisel	450	19
CB397	Wide flat chisel	178	35
CB397-300	Wide flat chisel	300	35
CB397-450	Wide flat chisel	450	35
CB398	Wide flat chisel, bent	178	35

Shank size 12,7 mm square, with recess

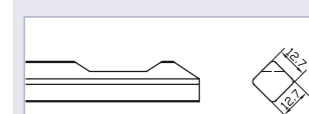

FOR HAMMERS
- Toku TFC-257H

Ordernumber	Description	L (mm) total	B (mm)
CB382	Flat chisel	178	19
CB382-12	Flat chisel	300	19
CB382-18	Flat chisel	450	19
CB383	Wide flat chisel	178	35
CB383-12	Wide flat chisel	300	35
CB384	Wide flat chisel, bent	178	35
CB380	Wide flat chisel	178	50
CB380-3	Wide flat chisel	200	75
CBMCOIR180	Slotting tool with carbide tip	200	38

Shank size JUMBO square

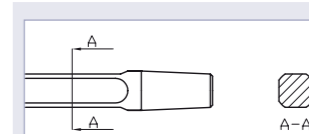

FOR HAMMER
- IR9001 (e.g.)

Ordernumber	Description	L (mm) total	B (mm)
CB296	Moil point	250	-
CB297	Moil point	300	-
CB276	Flat chisel	250	24
CB276-12	Flat chisel	300	24
CB276-18	Flat chisel	450	24
CB278 ¹⁾	Punch	250	-
CB279 ²⁾	Punch	250	-
CB280 ³⁾	Punch	250	-
CB281 ⁴⁾	Punch	250	-
CB282 ⁵⁾	Punch	250	-
CB283 ⁶⁾	Punch	250	-
CB284 ⁷⁾	Punch	250	-

¹⁾ Diameter 10 mm ³⁾ Diameter 16 mm ⁵⁾ Diameter 22 mm ⁷⁾ Diameter 28 mm

²⁾ Diameter 13 mm ⁴⁾ Diameter 19 mm ⁶⁾ Diameter 25 mm

Chisels for electric hammers

Chisels for electric hammers

Shank size Ø 11 mm x 30 mm

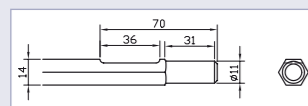

FOR HAMMER
- Bosch UBH4, 11205

Ordernumber	Description	L (mm) total	B (mm)
CB2091	Moil point	300	-
CB2093	Flat chisel	300	24
CB2095	Wide flat chisel	300	40

Shank size Ø 12 mm x 40 mm

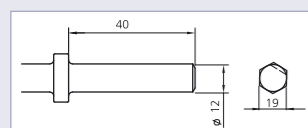

FOR HAMMER
- Makita HK1800

Ordernumber	Description	L (mm) total	B (mm)
CB3166010018	Moil point	180	-
CB3166026015	Flat chisel	180	20
CB3166020015	Wide flat chisel	150	50

Shank size Ø 12,9 mm x 77 mm

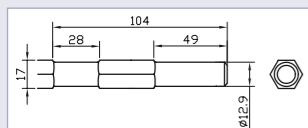

FOR HAMMER
- Makita 0810, 8035

Ordernumber	Description	L (mm) total	B (mm)
CB2451	Moil point	280	-
CB2452	Moil point	450	-
CB2453	Flat chisel	280	20
CB2454	Flat chisel	450	20
CB2455	Wide flat chisel	280	40

Shank size Ø 12,9 mm x 77 mm

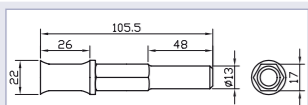

FOR HAMMER
- Hitachi Dh38YB

Ordernumber	Description	L (mm) total	B (mm)
CB2571	Moil point	280	-
CB2572	Moil point	450	-
CB2573	Flat chisel	280	20
CB2574	Flat chisel	450	20
CB2575	Wide flat chisel	280	50
CB2576	Wide flat chisel	450	50

Shank size 13 mm Hex x 67 mm

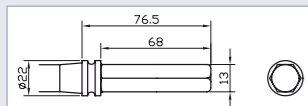

FOR HAMMER
- Duss P28

Ordernumber	Description	L (mm) total	B (mm)
CB2271	Moil point	340	-
CB2273	Wide flat chisel	340	40

Shank size Ø 14 mm x 52 mm

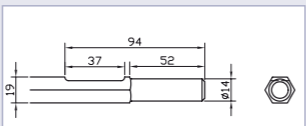

FOR HAMMER
- Kangoo 500

Ordernumber	Description	L (mm) total	B (mm)
CB2391	Moil point	300	-
CB2392	Moil point	380	-
CB2393	Moil point	450	-
CB2395	Flat chisel	300	24
CB2397	Flat chisel	450	24
CB2412	Wide flat chisel	300	75

Shank size Ø 16 mm x 47 mm

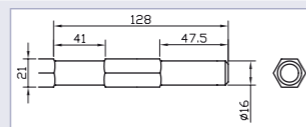

FOR HAMMER
- Makita Hm1200

Ordernumber	Description	L (mm) total	B (mm)
CB2481	Moil point	320	-
CB2482	Moil point	450	-
CB2483	Flat chisel	320	20
CB2484	Flat chisel	450	20
CB2485	Wide flat chisel	320	50
CB2485-70	Wide flat chisel	320	70

Shank size 16 mm Hex x 100 mm

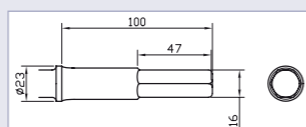

FOR HAMMERS
- Duss PK35, PK40, PK45, PK75

Ordernumber	Description	L (mm) total	B (mm)
CB2291	Moil point	400	-
CB2293	flat chisel	400	24
CB2295	Wide flat chisel	360	50

Shank size Ø 16,3 mm x 19 mm

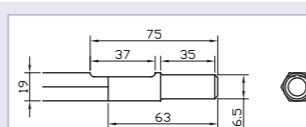

FOR HAMMERS
- Bosch USH6, UBH6, 11206

Ordernumber	Description	L (mm) total	B (mm)
CB2061	Moil point	300	-
CB2063	Moil point	400	-
CB2066	Flat chisel	300	24
CB2068	Flat chisel	400	24
CB2072	Wide flat chisel	400	50

Shank size Ø 17 mm x 39 mm

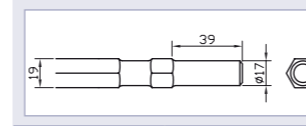

FOR HAMMER
- Hilti TP400

Ordernumber	Description	L (mm) total	B (mm)
CB2710	Moil point	360	-
CB2711	Moil point	500	-
CB2712	Flat chisel	360	23
CB2713	Flat chisel	500	23

Shank size Ø 19 mm x 61 mm

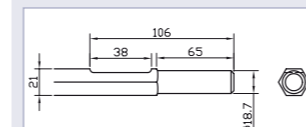

FOR HAMMER
- Kangoo 900/950

Ordernumber	Description	L (mm) total	B (mm)
CB2361	Moil point	300	-
CB2362	Moil point	380	-
CB2363	Moil point	450	-
CB2364	Moil point	600	-
CB2365	Flat chisel	300	24
CB2366	Flat chisel	380	24
CB2367	Flachmeißel	450	24
CB2368	Flat chisel	600	24
CB2381	Wide flat chisel	300	50
CB2381-L	Wide flat chisel	380	50
CB2382	Wide flat chisel	300	75
CB2382-L	Wide flat chisel	380	75
CB2372	Digging chisel	480	100
CB9915	Digging chisel	310	140
CB944484	Adaptor for floorscraper	450	-
CB100134	Floorscraper	270	150
CB100156	Blade for floorscraper M10	-	150
CB100156-M12	Blade for floorscraper M12	-	150
CB861040K	Repair kit for floorscraper M10	-	-
CB861040K-M12	Repair kit for floorscraper M12	-	-
CB12251023025	Adaptor for bush head	250	-

Shank size 19 mm Hex with recess

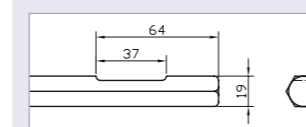

FOR HAMMER
- Bosch USH10, 11305

Ordernumber	Description	L (mm) total	B (mm)
CB2031	Moil point	300	-
CB2032	Moil point	400	-
CB2034	Moil point	600	-
CB2035	Flat chisel	300	24
CB2036	Flat chisel	400	24
CB2038	Flat chisel	600	24
CB2049	Wide flat chisel	300	50
CB2050	Wide flat chisel	400	50
CB2051	Wide flat chisel	300	75

Shank size 19 mm Hex x 82,5 mm

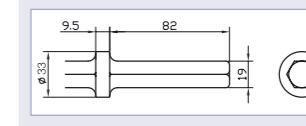

FOR HAMMER
- Wacker

Ordernumber	Description	L (mm) total	B (mm)
CB2901	Moil point	330	-
CB2903	Moil point	500	-
CB2904	Flat chisel	330	24
CB2906	Flat chisel	500	24
CB2907	Wide flat chisel	330	65

Shank size Ø 20 mm x 48,5 mm

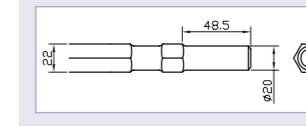

FOR HAMMER
- Hilti TP800

Ordernumber	Description	L (mm) total	B (mm)
CB2760	Moil point	360	-
CB2761	Moil point	500	-
CB2762	Flat chise	360	25
CB2763	Flat chise	500	25

Shank size 22 mm Hex

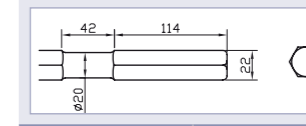

Ordernumber	Description	L (mm) total	B (mm)
CB15101000050	Moil point	500	-
CB15102030050	Flat chisel	500	30
CB914659	Wide flat chisel	500	50
CB914669	Wide flat chisel	500	75

Shank size 22 mm Hex with recess

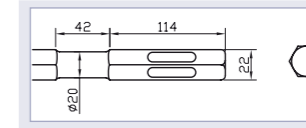

FOR HAMMER
- Duss PK160, PK300

Ordernumber	Description	L (mm) total	B (mm)
CB100526	Moil point	400	-
CB100533	Moil point	500	-
CB100527	Moil point	600	-
CB100528	Moil point	650	-
CB100529	Flat chisel	400	28
CB100534	Flat chisel	500	28
CB100530	Flat chisel	600	28
CB100531	Flat chisel	650	28
CB100535	Wide flat chisel	500	50
CB100532	Wide flat chisel	600	50

Chisels for electric hammers

Drills for electric hammers

Shank size Ø 24 mm x 55 mm

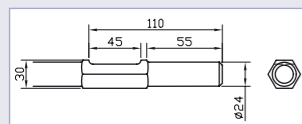

FOR HAMMERS
- Makita
- Hitachi

Ordernumber	Description	L (mm) total	B (mm)
CB3021	Moil point	400	-
CB3022A *	Moil point	400	32
CB3022B *	Flat chisel	400	32
CB3023A *	Wide flat chisel	400	75
CB3023B *	Wide flat chisel	400	75
CB3024A *	Asphalt cutter	400	125
CB3024B *	Asphalt cutter	400	125

* Type A: recess parallel on flat side of the spade, type B: crosswise

Shank size 28 mm Hex with recess

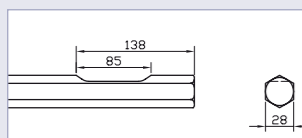

FOR HAMMERS
- Bosch USH27, 11304

Ordernumber	Description	L (mm) total	B (mm)
CB2001	Moil point	400	-
CB2003	Flat chisel	400	35
CB2005	Wide flat chisel	400	75
CB2007	Asphalt cutter	400	115

Shank size



FOR HAMMER
- Impex EH25

Ordernumber	Description	L (mm) total	B (mm)
CBEH25MP	Moil point	250	-
CBEH25NC	Flat chisel	250	20
CBEH25WF	Wide flat chisel	250	40
CBMCOEH25	Slotting tool with carbide tip	250	35

Shank size HILTI TE805 and TE905

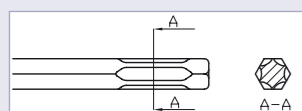

FOR HAMMERS
- Hilti TE805, TE905

Ordernumber	Description	L (mm) total	B (mm)
CB914972	Moil point	360	-
CB914974	Moil point	500	-
CB914982	Flat chisel	360	29
CB914984	Flat chisel	500	29
CB914992	Wide flat chisel	360	55
CB914994	Wide flat chisel	500	50
CB914995	Wide flat chisel	360	80
CB914996	Wide flat chisel	500	75

SDS plus

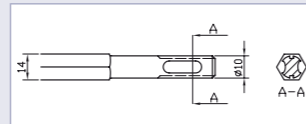

Ordernumber	Description	L (mm) total	B (mm)
CB2101	Moil point	250	-
CB2102V	Flat chisel	250	20
CB2103	Wide flat chisel	250	40
CBMCOSDSPUSKORT	Slotting tool with carbide tip	165	35
CBMCOSDSPUSLANG	Slotting tool with carbide tip	200	35

SDS max

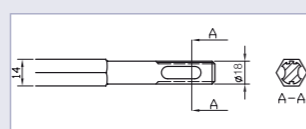

Ordernumber	Description	L (mm) total	B (mm)
CB04001	Moil point	280	-
CB04037	Moil point	360	-
CB04002	Moil point	400	-
CB04003	Moil point	600	-
CB04033	Flat chisel	1000	-
CB04004	Flat chisel	280	25
CB04005	Flat chisel	400	25
CB04006	Flat chisel	600	25
CB04034	Flat chisel	1000	25
CB04007	Hollow gouge	300	26
CB04007-33	Hollow gouge	300	33
CB04009	Wide flat chisel	400	50
CB04010	Wide flat chisel	300	80
CB04013	Wide flat chisel	350	115
CB04011	Wide flat chisel, bent	300	50
CB04012	Wide flat chisel, bent	300	80
CB04017	Adaptor for bush head	250	-
CB04154	Drill chuck-adaptor ¹⁾	200	-
CB04155	Drill chuck-adaptor ²⁾	165	-
CBMCOMAX	Slotting tool with carbide tip	280	-
CB914978	Adaptor for floorscraper	450	-
CB100134	Floorscraper	270	150
CB100156	Blade for floorscraper M10	-	150
CB100156-M12	Blade for floorscraper M12	-	150
CBB61040K	Repair kit for floorscraper M10	-	-
CBB61040K-M12	Repair kit for floorscraper M12	-	-

¹⁾ Drill chuck adaptor SDS-Max / SDS-Plus

²⁾ Drill chuck adaptor SDS-Max / Chuck

Drills SDS PLUS DURO ULTRA

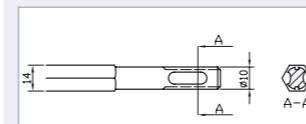

Ordernumber	L (mm) total	Ø (mm)	Ordernumber	L (mm) total	Ø (mm)	Ordernumber	L (mm) total	Ø (mm)
4C411	110	4	4C1011	110	10	4C1620	200	16
4C416	160	4	4C1016	160	10	4C1625	250	16
4C511	110	5	4C1021	210	10	4C1630	300	16
4C516	160	5	4C1026	260	10	4C1645	450	16
4C516	160	5	4C1031	310	10	4C1660	600	16
4C5511	110	5,5	4C1036	360	10	4C1680	800	16
4C5516	160	5,5	4C1045	450	10	4C16100	1000	16
4C5521	210	5,5	4C1060	600	10	4C1820	200	18
4C611	110	6	4C10100	1000	10	4C1825	250	18
4C616	160	6	4C1216	160	12	4C1830	300	18
4C621	210	6	4C1221	210	12	4C1845	450	18
4C626	260	6	4C1226	260	12	4C1860	600	18
4C6511	110	6,5	4C1230	300	12	4C18100	1000	18
4C6516	160	6,5	4C1245	450	12	4C2020	200	20
4C6521	210	6,5	4C1260	600	12	4C2025	250	20
4C6525	250	6,5	4C12100	1000	12	4C2030	300	20
4C711	110	7	4C1315	150	13	4C2045	450	20
4C716	160	7	4C1416	160	14	4C2060	600	20
4C721	210	7	4C1420	200	14	4C20100	1000	20
4C811	110	8	4C1425	250	14	4C2260	600	22
4C816	160	8	4C1430	300	14	4C22100	1000	22
4C821	210	8	4C1445	450	14	4C2445	450	24
4C826	260	8	4C1460	600	14	4C2545	450	25
4C830	310	8	4C14100	1000	14	4C2560	600	25
4C845	450	8	4C1515	150	15	4C25100	1000	25
4C860	600	8	4C15125	250	15			
4C916	160	9						
4C921	210	9						

Drills SDS MAX with X-head*

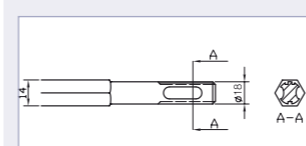

Ordernumber	L (mm) total	Ø (mm)	Ordernumber	L (mm) total	Ø (mm)	Ordernumber	L (mm) total	Ø (mm)
CB04050	305	12 ¹⁾	CB04203	540	19	CB04095	520	26
CB04051	390	12 ¹⁾	CB04084	370	20	CB04096	370	28
CB04052	540	12 ¹⁾	CB04085	520	20	CB04097	570	28
CB04201	305	14 ¹⁾	CB04086	920	20	CB04099	370	30
CB04054	390	14 ¹⁾	CB04087	370	22	CB04100	570	30
CB04055	540	14 ¹⁾	CB04088	520	22	CB04101	370	32
CB04056	390	15 ¹⁾	CB04089	920	22	CB04102	570	32
CB04057	540	15 ¹⁾	CB04090	370	24	CB04103	920	32
CB04080	390	16	CB04092	520	24	CB04105	570	35
CB04081	540	16	CB04092	370	25	CB04108	570	38
CB04202	920	16	CB04093	520	25	CB04110	570	40
CB04082	390	18	CB04094	920	25			
CB04083	540	18	CB04204	370	26			

¹⁾ Until 15 mm with 2 blade-cutting head

Drills for air hammers

Monobloc-drills shank 14.8 mm Hex x 89 mm combi for hammers TH-5S

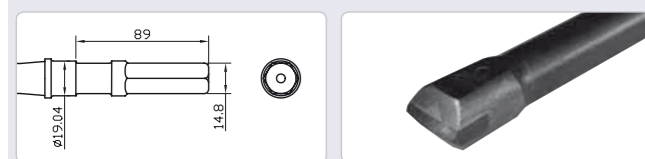

Ordernumber	L (mm) total	Ø (mm)
CB9F33013	330	13
CB9F33016	330	16
CB9F43016	430	16
CB9F33019	330	19
CB9F43019	430	19
CB9F33022	330	22
CB9F43022	430	22

Drill bit crossheads, Konus II

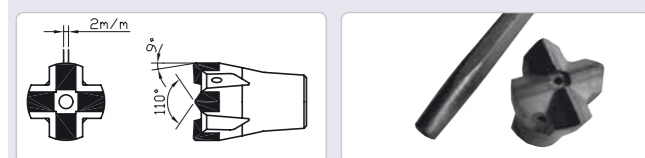

Ordernumber	L (mm) total	Ø (mm)
CB6126300030	-	30
CB6126300032	-	32
CB6126300034	-	34
CB6126300036	-	36
CB6126300038	-	38
CB6126300040	-	40
CB6126300045	-	45
CB6126300050	-	50
CB6126300055	-	55

Drill bars shank 22 mm Hex x 108 mm, Konus II for hammers - Toku TJ-15LBS / TJ-20LBS

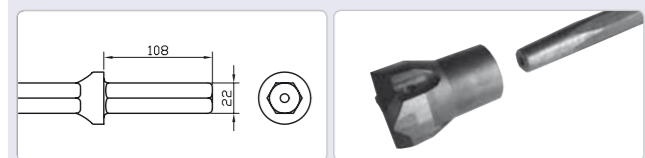

Ordernumber	L (mm) total	Ø (mm)
CB2261510500	500	-
CB2261510800	800	-
CB2261511000	1000	-
CB2261511500	1500	-
CB2261512000	2000	-
CB2261512500	2500	-
CB2261513000	3000	-

Monobloc-drills shank 19 mm Hex x 50 mm

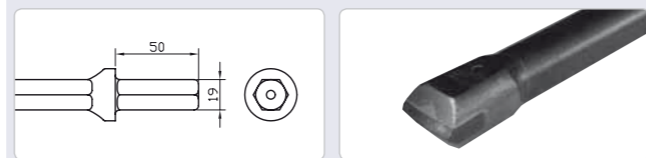

Ordernumber	L (mm) total	Ø (mm)
CB19525014	250	14
CB19535014	350	14
CB19550014	500	14
CB19525016	250	16
CB19535016	350	16
CB19550016	500	16
CB19525018	250	18
CB19535018	350	18
CB19540018	400	18
CB19550018	500	18
CB19535020	350	20
CB19540020	400	20
CB19540022	400	22
CB19530024	300	24

Monobloc-drills shank 22 mm Hex x 108 mm for hammers - Toku TJ-15LBS / TJ-20LBS

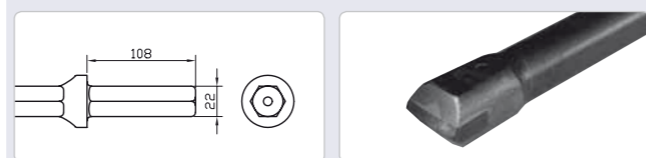

Ordernumber	L (mm) total	Ø (mm)
CB2240016	400	16
CB2260016	600	16
CB2240019	400	19
CB2260019	600	19
CB22100019	1000	19
CB2230022	300	22
CB2240022	400	22
CB2260022	600	22
CB22100022	1000	22
CB2240025	400	25
CB2260025	600	25
CB22100025	1000	25
CB2260028	600	28
CB2260030	600	30

Needle scalars

Straight- and pistol models



Type	Brand	Bore diameter mm	Stroke mm	Blows p/min	Air cons. l/s	Weight kg	Inlet-thread	Hose diameter mm	Vibration m/s ²	Noise level dB(A)
YK-2 ¹⁾	YOKOTA	24,0	33,0	8.000	6,0	2,5	PT 3/8"	6,5	5,6	85
TFC-N200	TOKU	20,0	10,0	12.000	4,1	1,12	PT 1/4"	6,5	14,3	91
F-25N	YOKOTA	25,0	22,0	4.000	6,0	2,3	PT 1/4"	6,5	10,0	78
RR-0315NS	RRA	25,0	32,0	4.000	6,6	2,6	PT 1/4"	6,5	9,4	93
RR-2110NS	RRA	23,5	33,0	3.000	6,6	2,5	PT 1/4"	6,5	20,0	96
RRI-4006	RRI	23,5	34,0	3.000	2,6	2,6	PT 1/4"	6,5	17,0	90
RRI-4006VL ²⁾	RRI	23,5	34,0	2.400	1,9	2,7	PT 1/4"	6,5	2,7	90
RRI-4007	RRI	30,5	30,5	2.500	3,3	4,3	PT 1/4"	6,5	12,0	91
RRI-4007VL ²⁾	RRI	34,4	30,5	3.000	2,6	3,4	PT 1/4"	6,5	1,9	95
RRI-4008	RRI	33,0	35,5	2.100	4,8	5,9	PT 1/4"	6,5	13,0	90

¹⁾ Scaler/scabler / ²⁾ Vibration reduced

DIMENSIONS	Type	A mm	B mm
	YK-2	489	126
F-25N	412	43	
RR-0315NS	415	45	
RR-2110NS	340	175	
RRI-4006	330	48	
RRI-4006VL	340	48	
RRI-4007	460	57	
RRI-4007VL	330	48	
RRI-4008	475	66	
TFC-N200	273	36	

NEEDLEHOLDERS	For type	2 mm	3 mm	4 mm
	TFC-N200	Y3-06-12-220	Y3-06-12-200*	-
F-25N	-	6203-0829-02-00*	-	-
RR-0315NS	-	SG0315NS-25*	-	-
RR-2110NS	SG-2110NS-24	SG-2110NS-17*	-	-
RRI-4006	218	217*	-	-
RRI-4006VL	601.2020	601.2030*	-	-
RRI-4007	330	314*	353	-
RRI-4007VL	601.3020	601.3030*	601.3040	-
RRI-4008	-	414	453*	-

* Supplied as standard

NEEDLE FOR TYPE	Needle for type	Number 2 mm	Number 3 mm	Number 4 mm
	TFC-N200		21	12
F-25N		-	19	-
RR-0315NS		-	19	-
RR-2110NS		29	19	-
RRI-4006		51	19	-
RRI-4006VL		51	19	-
RRI-4007		65	28	19
RRI-4007VL		65	28	19
RRI-4008		-	49	35

All needle scalars are supplied as standard with 3 mm needles, except RRI-4008 which is supplied with 4 mm needles.

NEEDLES	Order number	Ø	Model
	6203-0827-02-01	2 mm	Blunt, hardened steel
6203-0827-03-01*	3 mm	Blunt, hardened steel	
6203-0827-03-02	3 mm	Chisel point, hardened steel	
6203-0827-03-03	3 mm	Copper-beryllium	
6203-0827-04-01	4 mm	Blunt, hardened steel	

* Supplied as standard

For type	Order number	Ø
TFC-N200	Y3-06-12-210	3 mm

Power cutters

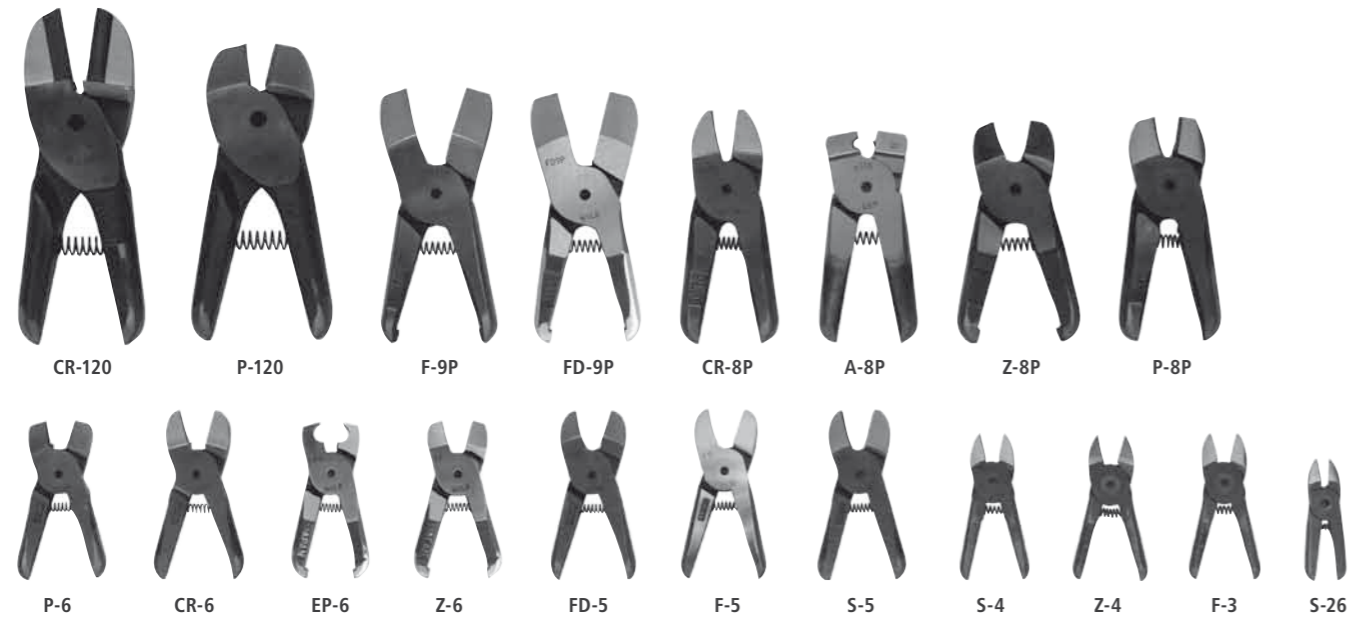

Type	Copper mm	steel FE 370 mm	Piano-wire mm	Plastics mm	Crimping mm	Blade type
RRI-8002	1,0	0,5	-	-	-	S-26
RRI-8003	1,6 1,6 -	1,0 1,0 -	- 0,5 -	- - 4,0	- - -	S-4 Z-4 F-3
RRI-8004	2,6 2,6 -	2,0 2,0 -	- 1,0 -	- - 7,0	- - -	P-6, CR-6, EP-6, S-5 Z-6 (caride tip) F-5, FD-5
RRI-8011	3,3 3,3 -	2,8 2,8 -	- 1,2 -	- - 10,0	- - 2,0	P-8P, CR-8P, EP-10P Z-8P (carbide tip) F-9P, FD-9P A-8P
RRI-8031	4,8 - -	4,0 - -	- - -	- 13,0 -	- - 5,5	P-8P, CR-8P, EP-10P F-9P, FD-9P A-8P
RRI-8032	7,0	6,0	-	-	-	P-120, CR-120

Power cutters are supplied without blade, please order separately from the list above.

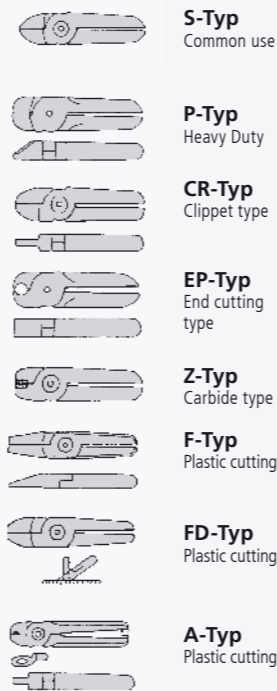

Power cutters

Cutting and pressing

Power cutters have simplified cutting and pressing in mass production. Versatile applications of the power cutter by selection of suitable blades, make it possible to increase production. The working pressure is 4-5 bar. Blades for power cutters are delivered separately.

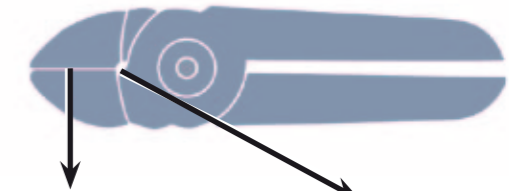

Caution: Only cut your piece of work in this area of the blade. Do not twist the tool when cutting! Cutting here will cause damage to the blade!

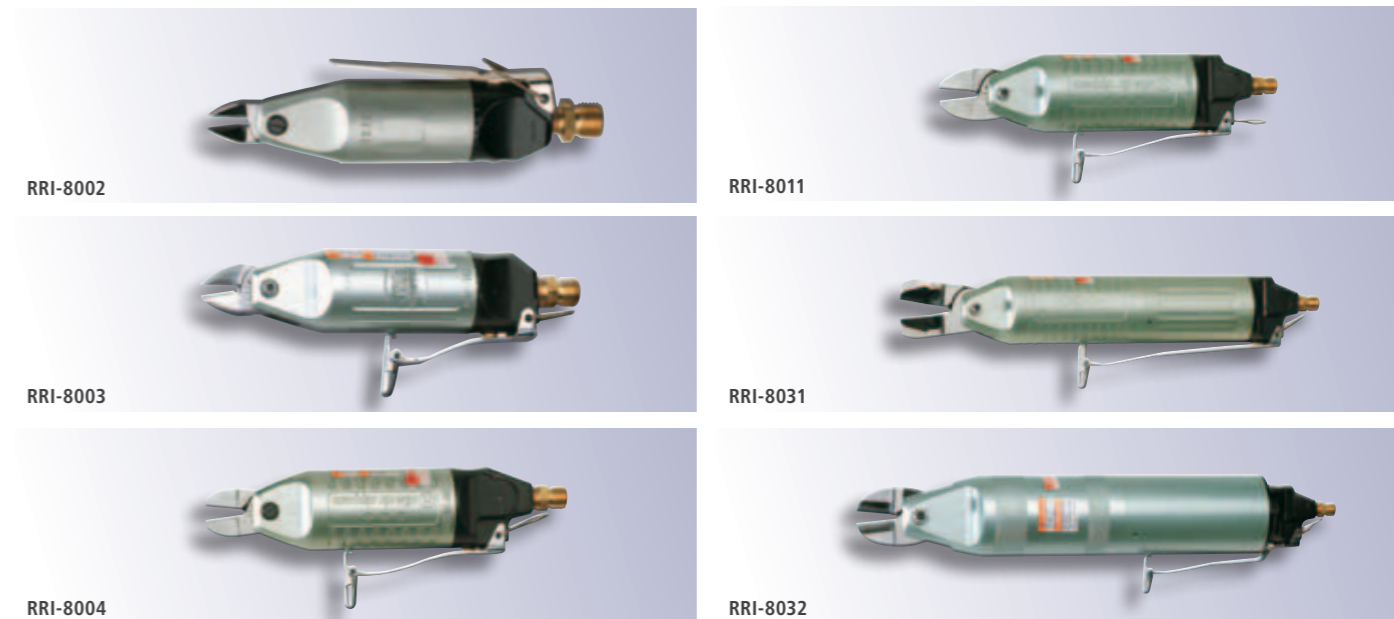

Type	Brand	Capacity copper mm	Capacity steel mm	Capacity plastics mm	Capacity crimping mm	Power midway on blade kg	Air cons. l/stroke	Weight kg**	Inlet-thread	Hose diameter mm	Vibration m/s ²	Noise level dB(A)
RRI-8002	RRI	1,0	0,5	-	-	400	0,064	0,13	PT 1/4"	6,5	0,2	71
RRI-8003	RRI	1,6	1,0	4,0	-	600	0,116	0,20	PT 1/4"	6,5	0,4	72
RRI-8004	RRI	2,6	2,0	7,0	-	1.400	0,23	0,34	PT 1/4"	6,5	0,3	73
RRI-8011	RRI	3,3	2,8	10,0	2,0	2.800	0,584	0,52	PT 1/4"	6,5	1,0	76
RRI-8031	RRI	4,8	4,0	13,0	5,5	4.500	0,956	0,83	PT 1/4"	6,5	1,0	75
RRI-8032	RRI	7,0	6,0	-	-	7.900	2,7	2,0	PT 1/4"	6,5	1,5	78

* Without blades (power cutters are supplied without blade, see for cutters and the choice of the blades p. 60)
** Steel FE 370

Type	DIMENSIONS	
	A mm	B mm
RRI-8002	30	104
RRI-8003	36	124
RRI-8004	45	156
RRI-8011	56	192
RRI-8031	56	280
RRI-8032	75	390

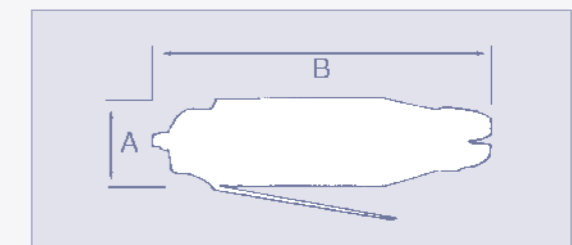

Saws

Chain saw



RRI-8560

Type	Brand	Length sawblade inch	Max capacity mm	RPM ¹	Power kW	Air cons. l/s	Weight kg	Inlet-thread	Hose diameter mm	Vibration m/s ²	Noise level dB(A)
RRI-8560	RRI	14"	340	18.000	1,5	50	7,6	BSP 3/4"	19	< 2,5 m/sec ²	98

Accessories for saws on page 64

Pipe saw



RRI-8460

This pipesaw of Red Rooster is intended for heavy industrial use.

Type	Brand	Capacity steel Ø mm	Strokes p/min	Stroke mm	Power kW	Air cons. l/s	Weight kg	Inlet-thread	Hose diameter mm	Vibration m/s ²	Noise level dB(A)
RRI-8460	RRI	45-530	300	65	1,1	20	8,0	BSP 3/4"	19	1,7	82

Accessories for saws on page 64

DIMENSIONS

Type	A mm	B mm	C mm	D mm	-
RRJ-8205	367	65	-	-	-
RRJ-8210	365	80	-	-	-
RRI-8350	400	134	-	-	-
RRI-8460	460	537	240	-	-
RRI-8560	340	650	20	200	-

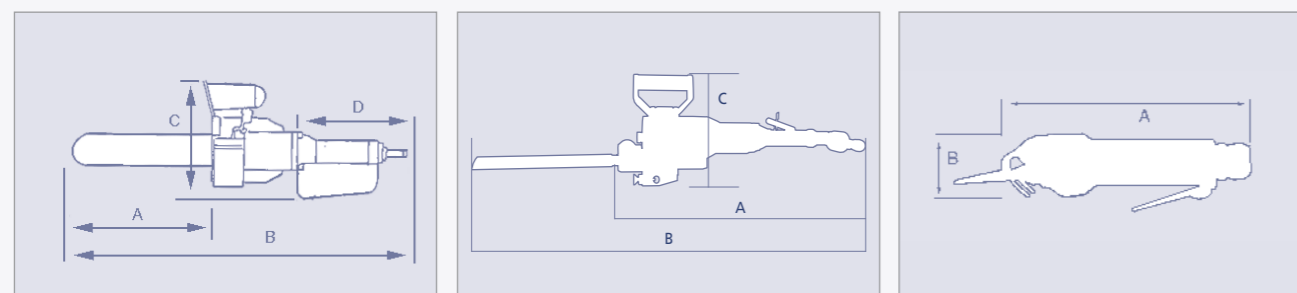

Saws

Reciprocating saws



RRJ-8205



RRJ-8210

Type	Brand	Capacity steel mm	Capacity aluminium mm	Strokes min ⁻¹	Stroke mm	Power kW	Air cons l/s	Weight kg	Inlet-thread	Hose diameter mm	Vibration m/s ²	Noise level dB(A)
RRJ-8205*	RRJ	10	12	5.000	25	0,25	2,8	0,96	PT 1/4"	6,5	3,5	79
RRJ-8210*	RRJ	3,1	3,9	9.500	10	0,25	2,8	0,51	PT 1/4"	6,5	3,5	78

* Standard supplied in set. Sawblades and universal air inlet joint are supplied as standard.

Accessories for saws on page 64

Characteristics:

- These tools have reduced vibration levels and are lightweighted.
- Both tools are delivered with a swivel joint that allows the tool to move very flexible despite the air-hose.
- The sawing tools are delivered in a blow molded case, including an assortment of saw-blades.
- The RRJ-8210 has a full composite body; the RRJ-8205 has a plastic layer over its housing, offering good thermal isolation.
- For thin (sheet-) material, the RRJ-8210 is the best choice of tool, whilst the RRJ-8205 is better for heavier sawing-jobs.
- Files in different shapes, sawblades and other accessories are available on request.

"Black Gator" Hacksaw



RRI-8350

Type	Brand	Capacity steel mm	Capacity wood mm	Strokes min ⁻¹	Stroke mm	Power kW	Air cons. l/s	Weight kg	Inlet-thread	Hose diameter mm	Vibration m/s ²	Noise level dB(A)
RRI-8350	RRI	12	120	1.200	45	0,4	4,2	2,8	PT 1/4"	6,5	4,7	83

Characteristics:

- The new Red Rooster Industrial RRI-8350 "Black Gator" saw has been developed to give low vibration (4,7 m/s²) and noise (83 dBA) levels.
- A perfect tool for repair and production jobs alike e.g Truck, Body, Aeromotive and petrochemical industries.
- The use of a balanced piston gives the tool an extremely smooth operation, providing extra comfort for the operator.
- Using a "D" Grip handle gives both comfort and safe use.
- The sawing frequency is adjustable to a maximum of 1200BPM.
- Both tool and sawblade are automatically lubricated giving the tool a longer working life.
- 8/12TPI & 14TPI blades are included in the set.

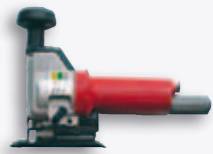

For RRI-8100

5-pack sawblades	8100-100-00	Chipboard, fiber, hard and soft wood 50 mm, soft synthetic materials up to 15 mm straight saw cut.
5-pack sawblades	8100-110-00	St37, non-iron plate, aluminium - 4 mm, stainless steel - 2mm, marble, fiber glass, reinforced plastics up to 2 mm
5-pack sawblades	8100-120-00	Hard- and soft wood - 60 mm, polyamide, polystyrene, soft synthetics up to 50 mm, rough saw cut



For RRJ-8205

5-er Pack Sägeblätter	8205-518-00	18-Zähne
Länge: 135 mm	8205-524-00	24-Zähne



For RRJ-8210

5-pack sawblades: 74 mm	31418-5	14 teeth/inch St37, V2A, wood, plastics, metal plate up to 2,5 mm
5-pack sawblades: 74 mm	31442-5	24 teeth/inch St37, V2A, aluminium, metal plate up to 2 mm
5-pack sawblades	31432-5	32 teeth/inch, St37, V2A, aluminium, metal plate up to 1 mm
Files	8210-501-00	5 mm, square
	8210-502-00	5 mm, round
	8210-503-00	5 mm, half-round
	8210-504-00	5 mm, triangle



For RRI-8350

5-pack sawblades	8350-510-00	280x19x0,9mm 10/1 HSS (crossed setting) To use for: stainless steel, wood with nails, hardwood
5-pack sawblades	8350-514-00	280x19x0,9mm 14/1 HSS (crossed setting) To use for: tube and profil from 2 mm diameter.
5-pack sawblades EXTRA STRONG	8350-610-14	J228x19x1,27mm 10-14/1 Vario (wavy setting) To use for: repair of pallets



For RRI-8460

Pipe clamp	8460-200-00	6"	
	8460-201-01	12"	
	8460-205-00	20"	
Extension chain	8460-201-50		
HSS-sawblades	Z22-11	200 x 25 x 1,5	22 teeth/inch
	Z22-10	200 x 25 x 1,5	16 teeth/inch
	Z22-6	300 x 25 x 1,5	16 teeth/inch
	Z22-7	400 x 25 x 1,5	16 teeth/inch
	Z22-72	500 x 28 x 2,0	14 teeth/inch
	Z22-73	600 x 28 x 2,0	14 teeth/inch
	Z22-75	770 x 28 x 2,0	12 teeth/inch
	Z22-31	300 x 25 x 1,5	12 teeth/inch
	Z22-30	530 x 28 x 1,5	12 teeth/inch
	Z22-37	940 x 32 x 2,0	12 teeth/inch
	Z22-9	200 x 25 x 1,5	8 teeth/inch
	Z22-29	400 x 25 x 1,5	8 teeth/inch
	Z22-74	600 x 28 x 2,0	8 teeth/inch
	Z22-71	300 x 25 x 1,5	4 teeth/inch
HSS-sawblade	Z22CT-06	300 x 25 x 2	16 teeth/inch
Sawblades tungsten carbide coating	ZCT-72	500 x 32 x 2,5	-
	ZCT-73	600 x 32 x 2,5	-



For RRJ-8210/8205/RRI-8350 (1/4")

Universal Swivel Joint 1/4"	922A18
-----------------------------	--------



For RRI-8560

Sawblade	140SPET041 DZ	*	Oregon
Chain	91VLX	*	Oregon

Blade and chain for the RRI-8550*

Sawblade	140SPEA041	*	Sandvik
Chain	91VG-52E	*	Sandvik

*The RRI-8550 is no longer available

Red Rooster Air Chain Hoists (0,125 - 6 Tonnes)

Red Rooster

The Red Rooster Air Chain Hoists are manufactured by Toku Japan. Japanese production stands for high quality and only the best materials are used. All parts are being produced with the smallest tolerances and best suitable heat treatment. Red Rooster Air Chain Hoists stands for Quality Air Chain Hoists.

Robust

The Red Rooster Air Chain Hoists are very robust and therefore very suitable for intensive use in industrial environs. The Red Rooster Air Chain Hoists are in many different type of industries, for example: on- and offshore, shipyards, on board of ships, foundry's, paper industry, paint shops, tank cleaning, (petro) chemical industry, galvanizing industry, food industry, automotive industry, construction and energy plants. Humid environment, outside in the field and aggressive atmosphere's, everywhere the combination of high performance, reliability and safety is required, Red Rooster has the best solution.

Features Red Rooster Air Chain Hoists:

- 100% duty rating
- Variable speed regulation, precise positioning of the load, soft start and stop, no shock movements
- Compact Design, low headroom
- Load limiter built-in from 1 ton (TCR 500 included) without loss of headroom
- Silenced
- Planetgear durable lubricated
- Safety factor 5
- End Stop system automatic at highest and lowest position of the chain
- Chain according EN 818 - 7
- Overload test at 150% of the WLL
- Spark free air motor
- Usable in explosion dangerous areas: CE II 3 GD c IIA T4
- Spark Resistant versions available for: CE II 2 GD c IIB T4
- Cord control or pendant control with emergency stop

Air Chain Hoists up to 100 tonnes

This catalogue only presents a small part of our extensive range of Air Chainhoists. The separate catalogue Red Rooster Airchainhoists is available on demand, and shows a big variety of different options and special solutions (see page 4).

Red Rooster Air Chain Hoists

Compact hoist for "material-Handling"

The Red Rooster compact hoists are suitable for "material-handling". The pendant control is direct on the lower hook, so the operator can control and position the load easily and direct. The perfect solution for horizontal movements is the combination with a push trolley.



TMM-140AE

TCR-250ME

FEATURES

- Pendant control direct on the lower hook
- Optimum load control, very precise positioning
- One-hand control
- Variable speed control
- Soft start and stop, no shock movements
- Handle can be positioned for left-hand or right-hand operation
- Endstop system

Red Rooster Air Chain Hoists

Mini air chain hoists light, strong & compact

The Red Rooster mini air chain hoists are besides industrial use also very suitable for "material handling". Due to the low weight are these hoists very suitable for service applications.



TCR-250DPE

TCR-250C

FEATURES

- Low weight and therefore very mobile, easy mounting
- TCR 250 only 7 kg, 3 meter lift included
- Precise variable speed control (cord - and pendant control)
- Very compact design
- Robust aluminium housing
- Air motor is cooled by the exhaust air (internal)
- Cord control or pendant control
- Quiet, low noise level, silenced
- Upper and lower limit switches

Type	Capacity t	Lifting speed full load m/min	Lowering speed full load m/min	Lifting speed without load m/min	Lowering speed without load m/min	Number of chain falls	Air consumption full load l/s	Inlet thread	Hose diameter mm	Weight kg incl. 3 m lift	Load limiter	Air trolley	4-button control with emergency stop (VTP-4E)	Chain size mm	Chain weight kg/m	Chain bag/chain bucket	SMC air treatment unit (+)
------	------------	-------------------------------	--------------------------------	----------------------------------	-----------------------------------	-----------------------	-------------------------------	--------------	------------------	--------------------------	--------------	-------------	---	---------------	-------------------	------------------------	----------------------------

Compact Hoist for "Material-Handling"

TMM-140AE	0,14	11,0	15	15,0	11	1 (câble)	8	PT 3/8"	13	9	-	+	-	-	-	-	AC30A-F03ET
TCR-250ME	0,25	8	16	19,0	13	1	11,7	PT 3/8"	13	11	-	+	-	4x12RTS	0,35	+	AC30A-F03ET

Red Rooster Mini Air Chain Hoists

TCR-125C	0,125	14	16	19	13	1	11,7	PT 3/8"	13	7	-	+	+	4x12RTS	0,35	+	AC30A-F03ET
TCR-125DPE	0,125	12,8	14,8	17,2	13	1	11,7	PT 3/8"	-	8,6	-	+	+	4x12RTS	0,35	+	AC30A-F03ET
TCR-250C	0,25	9,3	17	19,0	13	1	11,7	PT 3/8"	13	7	-	+	+	4x12RTS	0,35	+	AC30A-F03ET
TCR-250DPE	0,25	8,1	15,9	17,2	13	1	11,7	PT 3/8"	13	8,6	-	+	+	4x12RTS	0,35	+	AC30A-F03ET
TCR-500/2C	0,5	4,5	8,5	9,5	6,5	2	11,7	PT 3/8"	13	8,5	-	+	+	4x12RTS	0,35	+	AC30A-F03ET
TCR-500/2DPE	0,5	4,5	8,5	9,5	6,5	2	11,7	PT 3/8"	13	8,5	-	+	+	4x12RTS	0,35	+	AC30A-F03ET

TCS Air Chain Hoists high speed

TCS-500 C/PE	0,5	17	43	33	19	1	33	PT 1/2"	13	15,9	-	+	+	6,3 x 19,1	0,9	+	AC40A-F04ET
TCS-980/2 C/PE	0,99	8,5	21,5	16,5	9,5	2	33	PT 1/2"	13	16,8	-	+	+	6,3 x 19,1	0,9	+	AC40A-F04ET

Red Rooster Air Chain Hoists TCR series 0,25 - 6 tonnes

TCR-600250 C/P	0,25	10,5	17,9	20,5	13,4	1	25	PT 1/2"	13	31	*	+	+	6,3 x 19,1	0,9	+	AC40A-F04ET
TCR-500 C/P	0,5	10,5	17,9	20,5	13,4	1	25	PT 1/2"	13	31	*	+	+	6,3 x 19,1	0,9	+	AC40A-F04ET
TCR-1000/2 C/P	1	5,3	9,0	10,3	6,7	2	25	PT 1/2"	13	34	*	+	+	6,3 x 19,1	0,9	+	AC40A-F04ET
TCR-1000 C/P	1	6,0	10,3	11,3	6,8	1	25	PT 1/2"	13	35	*	+	+	7,1 x 21	1,1	+	AC40A-F04ET
TCR-2000/2 C/P	2	3,0	5,2	5,7	3,4	2	25	PT 1/2"	13	40	*	+	+	7,1 x 21	1,1	+	AC40A-F04ET
TCR-3000 C/P	3	2,8	4,6	5,4	3,3	1	33	PT 1/2"	19	69	*	+	+	11,2 x 34	2,2	+	AC40A-F04ET
TCR-6000/2 C/P	6	1,4	2,3	2,7	1,7	2	33	PT 1/2"	19	90	*	+	+	11,2 x 34	2,2	+	AC40A-F04ET

Technical specifications at 0,63 MPa (dynamic airpressure at 6,3 Bar)

* = standard, integrated / + = optional / - = not available

Red Rooster Air Chain Hoists

TCS Air Chain Hoists with high speed

These series Red Rooster Air Chain Hoists are especially developed for the "Material Handling Industry" for example: warehousing, packing etc. These hoists have very high lifting and lowering speed and are therefore also very suitable for applications with long lifting heights.



TCS-500

TCS-980

Air Chain Hoists TCR series 0,25 - 6 tonnes

These Red Rooster Air Chain Hoists are especially developed for heavy industrial use. Robust cast steel body. Valveblock same for all models, less spare parts. Standard with load limiter.



TCR-1000PE

TCR-3000PE

FEATURES

- Very high lifting and lowering speeds
- Maximum speed adjustable, lifting and lowering speed independent from each other
- Precise variable speed control (cord - and pendant control).
- Optimum control of the load, very precise positioning
- Compact and light weight.
- Exhaust hose easy to assemble
- Endstop system
- Air motor is cooled by the exhaust air (internal)
- Cord control or pendant control
- Chain bag standard
- Quiet, low noise level, silenced
- Aluminium housing
- Upper and lower limit switches

FEATURES

- Precise variable speed control (cord - and pendant control)
- Optimum control of the load, very precise positioning
- Compact design
- Upper and lower limit switches
- Load limiter built-in without loss of headroom
- Cord control or pendant control
- Quiet, low noise level, silenced
- Air pressure 0,4 - 0,63 MPa (4 - 6,3 Bar)

Special tools for the (assembly) industry

Tip dressers

Everybody has the problem of worn tips when working with spotwelding machines. They produce either poor welds or no welds at all. It reflects the quality and productivity of your work. Of course you can replace the worn tips for new ones. It might be a better idea to recondition the worn tips by means of Yokota tip dressers.

Dressing can be done by the worker by hand (YNR-type) or the tip dressers are integrated into the cycles of a spotwelding robot and programmed according to your own needs and wishes (TDN-type). The Yokota tip dressers do not only clean the surface, but also the original shapes and edges of the tips are restored.

Hog Ringers

The Yokota hog ringers are used for the assembly of carseats, chairs, beds, fencing etc. This tool is used to fix the cushion material or the leather material on the seatframe with hog rings.



YNR-8F

YHR-33L

Tip Dressers

Type	Brand	Tip capacity mm	RPM	Rotation L/R	Max. jaw capacity kg	Air cons. l/s	Weight kg	Inlet-thread	Hose diameter mm	Vibration m/s ²	Noise level dB(A)
YNR-8F*	YOKOTA	16	1.400	right	-	6,7	1,2	PT 1/4"	9,5	-	-
TDN-5D	YOKOTA	24	320	right	50	11,7	2,9	PT 3/8"	9,5	-	83
TDN-6	YOKOTA	24	320	left/right	170 / 650	15,8	6,5	PT 3/8"	13,0	-	84

* Hand model

Blades for tip dressers are separately available and will be custom made on tip specifications. On request we can supply you with detailed information.

Hog Ringers

Type	Brand	Max. number of rings	Ring size mm	Trigger-pressure kg	Stroke trigger mm	Air cons. l/s	Weight kg	Inlet-thread	Hose diameter mm	Vibration m/s ²	Noise level dB(A)
YHR-33	YOKOTA	120	8,0	0,6	7	0,8	1,5	PT 1/4"	6	1,66	79
YHR-33L*	YOKOTA	120	8,0	0,6	7	0,8	1,5	PT 1/4"	6	1,66	79

* Extended nose

FUNCTIONING OF THE-33(L)

Pull the trigger and caulk. The work is completed when releasing the trigger.

Push down

Stretch of seat.

C-Ring

 60 pcs./set

YHR-33/33L
 Dimensions after caulking.

Special tools

for the (assembly) industry

DIMENSIONS

Type	A mm	B mm	B* mm	C mm	-
YNR-8F	257	19,5	-	24	-
TDN-6	217	161	142	19	-
YHR-33	346	188	-	-	-
YHR-33L	361	188	-	-	-

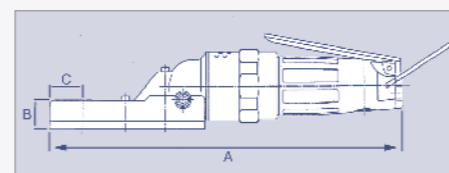
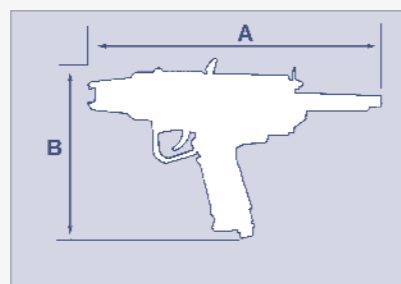
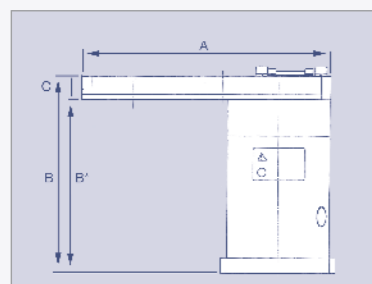

TAILOR-MADE TOOLS

Please inform us about your specific application needs, so we can make you a suitable proposal.
On this page some examples of our possibilities.



YEX-150S
with crowfoot



Y-70E
with crowfoot



YSA-4T-X1
Hub nut crimping tool



Y-61
with crowfoot



Y-61
with crowfoot



YED-240S
with crowfoot



TDN-5D

Various tools for several applications

Pumps

The Yokota YP pumps are high quality sump pumps for use on board of ships. The pumps are made of bronze and especially suitable to use in acid environments.

The Yokota barrelpump YPP-1 is developed to pump liquids from barrels, such as fuel, oil, water or chemicals.

In every workshop

These airtools should be available in every workshop. The engraving pen helps you to mark your (hand-)tools and produce type. Blow guns can be supplied in a simple Red Rooster variant or in a SMC model which will save you air and thus money.

Riveters

The Red Rooster riveters work with the most usual sizes of rivets. If the current handtools for the rivets are a burden for your employees, use the Red Rooster air-riveter.

Multi-cutter

The Red Rooster multi-cutter RR-476 is a true multi-talent. Sawing, sanding and cutting with only one tool.

Various tools

Sump- and barrel pumps

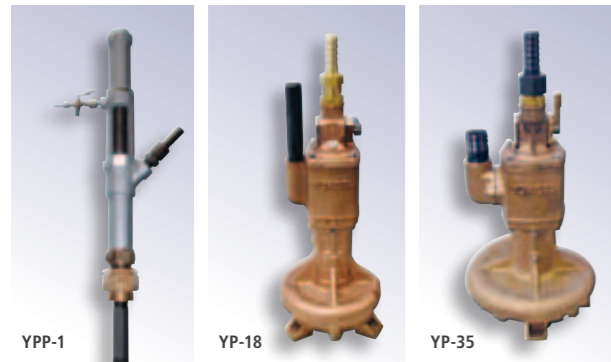

Type	Brand	Description	Max. capacity	Max. capacity m	Air-cons. l/s	Weight kg	Air hose Ø mm	Outlet hose Ø mm	Air return hose Ø mm
YPP-1*	YOKOTA	Piston pump	65 l/min	40	7,5	8,8	10	19	-
YP-18	YOKOTA	Bronze sump pump	55 t/h	25	33,0	19,0	19	65	25
YP-35	YOKOTA	Bronze sump pump	80 t/h	41	73,0	32,0	25	65	38

* YPP-1: Connection thread PT 1 1/2" / Inlet thread PT 1/4" / Outlet thread PT 3/4"

DIMENSIONS

Type	A mm	B mm	C mm
YPP-1	606	68	-
YP-18	525	189	250
YP-35	550	270	320

Option
Teflon-packings/seals for de YPP-1
7003-1009-11-11 8010-0315-11-11
7003-1014-11-11 9010-1026-11-11

Performance curve YPP-1

Performance curve YP-18

Performance curve YP-35

Type YPP-1 has been developed for pumping liquids from drums. The pump fits on standard oil-drums with a normal 1 1/2" pipe thread opening. The models YP-18 and YP-35 are manufactured throughout in bronze and are suitable to pump aggressive liquids like seawater.

DIMENSIONS

Type	A mm	B mm
RRI-4010	159	299
RRI-4011	198	315
RRI-9010	160	-
RRP-203	268	135
RRI-21930	80	250
RR-476	195	79
VMG	140	164

Various tools



Riveters

Type	Brand	Traction kg	Capacity rivets diameter	Air cons. l/stroke	Weight kg	Inlet-thread	Hose diameter mm	Vibration m/s ²	Noise level dB(A)
RRI-4010	RRI	900	until 4,8	1,15	1,5	PT 1/4"	6	1,5	76
RRI-4011	RRI	1.045	until 6,4	1,80	2,0	PT 1/4"	6	0,4	76

Engraving pen

Type	Brand	Needle diameter mm	Strokes p/min	Air cons. l/sec	Weight kg	Inlet-thread	Hose diameter mm	Vibration m/s ²	Noise level dB(A)
RRI-9010	RRI	1,7	36.000	0,5	0,25	R 1/4"	4	0,7	62

Caulking gun

Type	Brand	Tube Ø x mm	Working pressure bar	Air cons. l/sec	Weight kg	Inlet-thread	Hose diameter mm	Vibration m/s ²	Noise level dB(A)
RRP-203	RRA	50 x 215	0,2 - 0,4	-	1,1	PT 1/4"	6,5	-	-

Blow guns

Type	Brand	Air cons. l/sec	Weight kg	Inlet-thread	Hose diameter mm
RRI-21930	RRI	5	0,2	PT 1/4"	6,5
VMG11WF02	SMC	1 - 6 *	0,2	PT 1/4"	6,5

* Depending on nozzle size, to be ordered separately, see below.

ACCESSORIES

For type	Accessory	Order number	
RRI-4010	Nose piece 3,2 mm	10416-1	*
	Nose piece 4,0 mm	10416-2	*
	Nose piece 4,8 mm	10416-3	*
	Bottle for spent rivets	10448	*
	Wrench	10447	*
RRI-4011	Nose piece 2,4 mm	14463	*
	Nose piece 3,2 mm	14464	*
	Nose piece 4,0 mm	14465	*
	Nose piece 4,8 mm	14466	*
	Nose piece 6,4 mm	14468	*
	Rivet deflector	14470	
	Rivet collector (cloth)	612903	
Set key	14499		
RRI-9010	Engraving needle, fine	2-01-011-90	
	Engraving needle, medium	2-01-011-91	*
	Engraving needle, coarse	2-01-011-92	
VMG11WF02	Nozzle diameter 1 mm	KN-R02-100	
	Nozzle diameter 1,5 mm	KN-R02-150	
	Nozzle diameter 2 mm	KN-R02-200	
	Nozzle diameter 2,5 mm	KN-R02-250	

* Supplied as standard

Various tools

Multi-cutter

Type	Brand	Sawing capacity mm	Movements p/min	Air cons. l/stroke	Weight kg	Inlet-thread	Hose diameter mm	Vibration m/s ²	Noise level dB(A)
RR-476	RRA	1	0 - 22.000	6,5	1,1	PT 1/4"	6,5	2,6	90

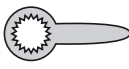
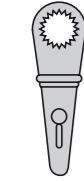
ACCESSORIES	Order number				Type				Dimension			
	Order number	Type	Dimension	Order number	Type	Dimension	Order number	Type	Dimension	Order number	Type	Dimension
	475G26	639-03-121-018	56/26 mm	475G35	639-03-073-011	56/35 mm	475G40	639-03-176-015	74/40 mm			
	475L16	639-03-122-011	16 mm	475LR16	639-03-099-010	16 mm	475L23	639-03-173-010	23 mm			
	475L25	639-03-124-013	25 mm	475L27	639-03-174-018	27 mm	475L45	639-03-168-018	45 mm			
	475LR46	639-03-179-011	46 mm	475LR54	639-03-160-015	54 mm	475LR58	639-03-097-018	58 mm			
	475L55	639-03-123-015	55/32 mm	475L80	639-03-171-013	80/70 mm	475L85	639-03-081-013	85/60 mm			
	475L85-1	639-03-125-017	85/70 mm	475L110	639-03-194-016	110 mm						
	475VZ14	639-03-120-019	14 mm	475VZ35	639-03-103-017	35 mm	475VZ35-1	639-03-103-015	35 mm			
	475VZ35-2	639-03-103-018	35 mm	475VZ35-3	639-03-164-019	35 mm	475VZ35-4	639-03-172-016	35 mm			
	475M12	639-03-129-050	12 mm	475M13	639-03-113-016	13 mm	475M17	639-03-144-011	17 mm			
	475M18-1	639-03-146-018	18 mm	475M25	639-03-105-019	25 mm	475M25-1	639-03-131-017	25 mm			
	475N10	639-03-132-010	-									
	475X19	639-03-208-010	19 mm	475X24	639-03-153-012	24 mm	475X25	639-03-207-012	25,4 mm			

Order number	Type	Dimension
475KR11*	639-03-189-010	11 mm
475KR14	639-03-082-016	14 mm
475KR16-1	639-03-133-014	16 mm
475KR16*	639-03-089-016	16 mm
475KR16/35	639-03-143-013	16/35 mm
475KR18/39	639-03-170-014	18/39 mm
475KR20/35	639-03-189-015	20/35 mm
475KR32/46	639-03-195-010	32/46 mm
475KR39	639-03-152-018	39 mm
475KR42/60	639-03-182-015	42/60 mm
475K45	639-03-072-17	45 mm
475KR60/76	639-03-169-012	60/72 mm

Order number	Type	Dimension
475U10	639-03-083-010	10 mm
475U16	639-03-095-011	16 mm
475U16-2	639-03-108-014	16 mm
475U18	639-03-087-019	18 mm
475U18-1	639-03-127-014	18 mm
475U19	639-03-118-013	19,5 mm
475U22	639-03-115-018	22 mm
475U24	639-03-076-016	24 mm
475U28	639-03-163-011	28 mm
475U32-2	639-03-191-011	32 mm
475U32	639-03-114-014	32 mm
475U32-1	639-03-147-012	32 mm
475U36	639-03-079-012	36 mm
475U40	639-03-110-010	40 mm
475U40-1	639-03-156-017	40 mm
475U45	639-03-154-010	45 mm
475U52	639-03-153-012	52 mm
475U60	639-03-101-010	60 mm
475U60-2	639-03-107-016	60 mm
475U60-3	639-03-157-011	60 mm
475U70	639-03-155-014	70 mm
475U95	639-03-111-019	95 mm

Sawblade	475101	Ø 63 mm - steel 1 mm
Sawblade	475801	Ø 80 mm - HSS
Sanding pad	475380	Grain 80
Sanding pad	4753150	Grain 150
Sanding pad	4753240	Grain 240
Sanding pad	476TP	Triangle

Typ RR-476 can be used as saw (with sawblade), for cutting urethane-bonded windows (with various blades) and as a sander (with triangle sanding pad).

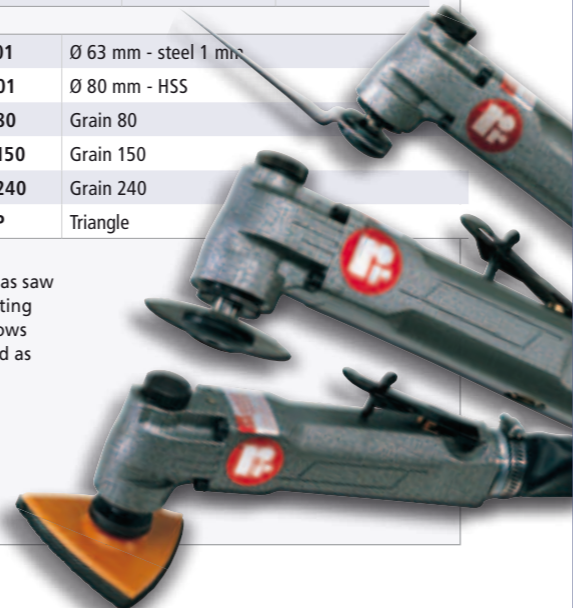

Accessories for air tools

Our delivery program is completed with an extended range of accessories for air tools. In this chapter you will find:

(Spring)balancers

In order to support the weight of pneumatic, hydraulic and electric tools, the use of a spring balancer should be considered. The performance of the tools will be speeded up due to good balance and reduced operator fatigue, when using a spring balancer.

Applications:

- When heavy tools/machines have to be portable.
- Fitting of centre lathe chuck.
- Transportation of parts in a production line.

The models ETL, ELB and TW from TW-9 upwards have a safety mechanism which starts working in case of spring breakage.

Polyurethane air hoses

No kinks after bending!

The hose stretches easily and retracts automatically. This increases productivity and safety.

Kombi-Kit

The combi-kit is a tool carrier complete with SMC filter/regulator/lubricator unit 3/8" type AC30-F03E + pressure gauge.

Lubricating oil

ATLUB is the perfect lubricant especially developed to meet the lubrication requirements of pneumatic tools. ATLUB is based on a water soluble synthetic lubricant, containing a well balanced choice of additives to obtain following properties:

- Very good protection against wear, corrosion and oxidation
- No forming of ice in pneumatic tools and machinery
- A good protection against deposit in the pneumatic system
- Good cleaning properties
- Compatibility with seal and gaskets made from synthetic material

ATLUB can be used in an air-line or microfog lubricator for lubrication of hammers, pile-drivers drills, grinders, pumps, hoists, clamps and vices. ATLUB will not mix with other mineral oils. With ATLUB as the lubricant it is possible to work at very low temperatures, even at - 25°C, without freezing of the pneumatic system.

Regulators

Suitable to control the airflow directly at the air-connection of the tool.

(Spring)balancers

Accessories

Standard model

Type	Brand	Capacity kg	Cable length m	Weight kg
RRI-9001/1	RRI	0,5 - 1,5	2,0	0,5
RRI-9003/1	RRI	1,0 - 3,0	2,0	0,7
RRI-9005/1	RRI	2,5 - 5,0	2,0	0,9
EK-00	RRI	0,5 - 1,5	0,5	0,2
EK-0	RRI	0,5 - 1,5	1,0	0,5
TW-3	RRI	1,0 - 3,0	1,3	1,4
TW-5	RRI	2,5 - 5,0	1,3	1,5
TW-9	RRI	4,5 - 9,0	1,3	3,4
TW-15	RRI	9 - 15	1,3	3,8
TW-22	RRI	15 - 22	1,5	7,2
TW-30	RRI	22 - 30	1,5	7,6
TW-40	RRI	30 - 40	1,5	9,8
TW-50	RRI	40 - 50	1,5	10,4
TW-60	RRI	50 - 60	1,5	11,6
TW-70	RRI	60 - 70	1,5	11,8
ETP-14	RRI	120 - 140	1,2	24,1
ETP-15	RRI	140 - 170	1,2	28,7
ETP-16	RRI	170 - 200	1,2	29,7



Hosereel with integrated cable

Type	Brand	Capacity kg	Cable length m	Weight kg	Hose diameter mm	Air cons. l/min	Inlet-thread
HTB-0	RRI	0,5 - 1,5	1,3	1,58	6,5	700	PT 1/4"
HTB-1	RRI	1,5 - 3,0	1,3	1,66	6,5	700	PT 1/4"
HTB-2	RRI	3,0 - 5,0	1,3	1,73	6,5	700	PT 1/4"



Long stroke

Type	Brand	Capacity kg	Cable length m	Weight kg
ELF-3	RRI	1,5 - 3,0	2,5	4,1
ELF-5	RRI	3 - 5,0	2,5	4,2
ELF-9	RRI	5 - 9	2,5	4,7
ELF-15	RRI	9 - 15	2,5	10
ELF-22	RRI	15 - 22	2,5	10,2
ELB-30 (ELF-30)	RRI	22 - 30	2,5	11
ELF-40	RRI	30 - 40	2,5	14
ELF-50	RRI	40 - 50	2,5	14,5
ELF-60	RRI	50 - 60	2,5	17
ELF-70	RRI	60 - 70	2,5	18



Extra safety

The models ETP, ELB and TW from TW-9 upwards have a safety mechanism which starts working in case of spring breakage.

Polyurethane spiral air hoses

Type	Brand	Working length m	Total length m	Inside diameter mm	Outside diameter mm	Joint connection
PT-02510SJ	RR	2,0	2,5	6,5	9,5	1/4"
PT-02525SJ	RR	4,0	5,0	6,5	9,5	1/4"
PT-02550SJ	RR	9,0	10,0	6,5	9,5	1/4"
PT-03525SJ	RR	4,0	5,0	8,0	12,0	1/4"
PT-03550SJ	RR	9,0	10,0	8,0	12,0	1/4"
PT-04525SJ	RR	4,2	4,7	9,5	13,5	3/8"
PT-04550SJ	RR	9,0	10,0	9,5	13,5	3/8"

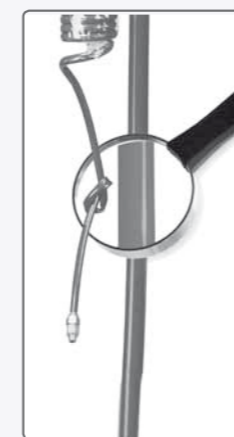

Features

- Both ends executed with universal swivel-joints
- Provided with straight ends of 10 and 50 cm
- Increased flexibility, no kinks after bending
- Max. pressure 8 bar
- Oil and petrol resistant
- Temperature -20°C. up to +60°C
- Swivel executed with ballbearings
- Very well suitable in combination with balancers

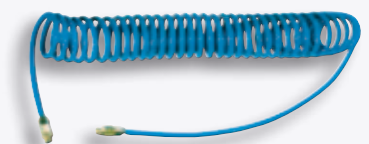
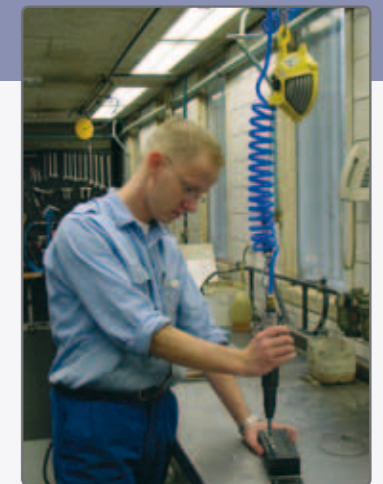

Polyurethane air hoses

Regulator

Features

- Can be easily inserted in the inlet of any air tool
- Reduces the flow of air and the power speed of the air tool



Type	Produkt	Description	Inlet-thread
8130-1001-00-00	Yokota	Stepless setting	PT 1/8"
8130-1002-00-00	Yokota	Stepless setting	PT 1/4"
8130-1003-00-00	Yokota	10 steps setting	PT 1/4"

Universal Swivel Joint

Features

- Optimal ergonomics
- Swivels in all directions
- Handling your air tools is more flexible now



Type	Order number
Universal Swivel Joint 1/4"	922A18
Universal Swivel Joint 3/8"	933A19
Universal Swivel Joint 1/2"	944A

VOKIT-100



KIT-100-KIT

Type	Brand	Description	Height cm	Width cm	Depth cm	Height box cm
KIT-100-KIT (with AC30-F03E)	RR	Kombi-kit	40,5	25,5	32	7
VOKIT-100	RR	Empty Kombi-kit	40,5	25,5	32	7

Oil



Type	Brand	Description	Quantity Liter
ATLUB	RR	Lubricating oil	1
NOBP	RR	Oil for Yokota impulse wrenches	1
01-0508	RR	Oil for Red Rooster impulse wrenches	0,1

Air treatment equipment Applications

If the pressure is too low the tool will show less performance and less precision, resulting in slow starting and less productivity. 1 bar pressure reduction means 25% power loss. Good quality air ensures a trouble-free use, longer lifetime and reduces maintenance costs significant.

Low pressure may occur if:

- The capacity of the compressor is insufficient
- The air piping has been pitched incorrectly
- There are air leaks
- The air treatment equipment is not functioning properly and/or not pitched correctly;
- The wrong size hose nipples or quick couplers are used
- The tank is too small

Waterseparators

With the SMC AMG water separators you can remove easily and cheaply 99% of water droplets. The water separators are compact and light weight. Available port sizes from 1/8" up to 2", therefore suitable for compressors (1-75 kW). Standard equipped with automatic drain for long term jobs.

Filters

The SMC filters have exceptional large air flow and a high rate of filtration. The filters guarantee a high level of the air quality due to separation of condensate by the centrifugal working and filtration of pollution.

Regulators

SMC regulators guarantee a constant secondary pressure, apart from fluctuations in port pressure or pressure decreases.

Lubricators

For precise lubrication of machine components. From series 3.000 oil can be filled under pressure. Easy and precise adjustment. Lubrication already takes place with slight pressure drop.

Air combination sets

Combination set exist of EAF (filter), EAR (regulator) and EAL (lubricator). Or EAW (filter/regulator combination) and EAL (lubricator).

Refrigerated air dryers

The SMC refrigerated air dryer series IDFA removes humidity from your compressed air system and extends thereby the life span of all of your air tools.

AMG-series

AMG-series - water separators

Type	Brand	Compressor kW	NI/min	Port size Rc	Weight kg	Mounting brackets	Filter elements
AMG150C-F02C	SMC	2,2	300	1/4"	0,38	BM51	AMG-EL150
AMG250C-F03D	SMC	5,5	750	3/8"	0,55	BM52	AMG-EL250
AMG250C-F04D	SMC	5,5	750	1/2"	0,55	BM52	AMG-EL250
AMG350C-F04D	SMC	11	1.500	1/2"	0,9	BM53	AMG-EL350
AMG450C-F06D	SMC	15	2.200	3/4"	1,4	BM54	AMG-EL450
AMG450C-F10D	SMC	15	2.200	1"	1,4	BM54	AMG-EL450
AMG550C-F10D	SMC	22	3.500	1"	2,1	BM55	AMG-EL550
AMG650-F14D	SMC	37	6.000	1½"	4,2	BM56	AMG-EL650
AMG850-F20D	SMC	75	12.000	2"	10,5	BM57	AMG-EL850

Working pressure: 1.5 - 10 bar / Temperature working area: -5 to 60°C.
Accessories like mounting brackets and filter elements available on request.



AMG

With the SMC water separators you can remove easy and cheaply 99% of water droplets. The water separators are compact and light weight. Available port sizes from 1/8" up to 2", therefore suitable for compressors (1-75 kW). Standard equipped with automatic drain for long term jobs. Long life due to the special resin with large mesh to reduce clogging.

You can use a water separator when:

1. air does not have to be dry for 100%
2. air dryer cannot be used
3. air dryer is expensive for needs

Note Mount filter as far as possible from the compressor for optimal functioning.

AC-series - filter-regulator-lubricator (modular)

AC-series - combination of AF (filter), AR (regulator), AL (lubricator) and pressure gauge

Type	Brand	Port size	NI/min	Filter micron	Working pres. (bar)	Bowl	Bowl with bajonet connection
AC20-F02E	SMC	1/4"	500	5	0,05 - 0,85	Polycarbonate	o
AC30-F03E	SMC	3/8"	2.000	5	0,05 - 0,85	Polycarbonate	s
AC40-F03E	SMC	3/8"	4.000	5	0,05 - 0,85	Polycarbonate	s
AC40-F04E	SMC	1/2"	4.000	5	0,05 - 0,85	Polycarbonate	s
AC40-F06E	SMC	3/4"	4.500	5	0,05 - 0,85	Polycarbonate	s
AC50-F06E	SMC	3/4"	5.000	5	0,05 - 0,85	Polycarbonate	s
AC50-F10E	SMC	1"	5.000	5	0,05 - 0,85	Polycarbonate	s
AC60-F10E	SMC	1"	7.000	5	0,05 - 0,85	Polycarbonate	s

o = optional, s = standard / Max. supply pressure: 1,0 MPa / Max. working pressure: 0,7 MPa / Temperature working area: -5 to 60° C.



AC

AC-Reihe - Kombination von AF (Filter/Regler Kombination), AL (Öler) und Manometer

Type	Brand	Port size	NI/min	Filter micron	Working pres. (bar)	Bowl	Bowl with bajonet connection
AC20A-F02E	SMC	1/4"	500	5	0,05 - 0,85	Polycarbonate	o
AC30A-F03E	SMC	3/8"	1.700	5	0,05 - 0,85	Polycarbonate	s
AC40A-F04E	SMC	1/2"	3.000	5	0,05 - 0,85	Polycarbonate	s
AC50A-F04E	SMC	1/2"	3.000	5	0,05 - 0,85	Polycarbonate	s

o = optional, s = standard / Max. supply pressure: 1,0 MPa / Max. working pressure: 0,7 MPa / Temperature working area: -5 to 60° C.



AC30A

On request

- Other combinations
- Automatic drain, normally opened (add CE for E in order number). For good functioning, the drain line should have min. 8 mm diam. and should not be longer than 5 m
- Filtration 2, 10, 20, 40, 70, 100 μ
- Metal- or nylon bowls

Polycarbonate bowls may be damaged and could possibly fail if they are exposed to synthetic oils, thinner solvents, trichloorethylene, kerosene and other aromatics hydrocarbons. If used in above atmosphere, please use a metal bowl (p.85).

AF-series (modular)

AF-series - Filters

Type	Brand	Port size	NI/min	Filter micron	Bowl	Bowl with bajonet connection	Mounting brackets
AF20-F02-A	SMC	1/4"	750	5	Polycarbonate	o	AF22P-050AS
AF30-F02-A	SMC	1/4"	1.450	5	Polycarbonate	s	AF32P-050AS
AF30-F03-A	SMC	3/8"	3.900	5	Polycarbonate	s	AF32P-050AS
AF40-F03-A	SMC	3/8"	3.900	5	Polycarbonate	s	AF42P-050AS
AF40-F04-A	SMC	1/2"	3.900	5	Polycarbonate	s	AF42P-050AS
AF40-F06-A	SMC	3/4"	3.900	5	Polycarbonate	s	AF42P-070AS
AF50-F06	SMC	3/4"	6.500	5	Polycarbonate	s	AF50P-050AS
AF50-F10	SMC	1"	6.500	5	Polycarbonate	s	AF50P-050AS
AF60-F10	SMC	1"	9.800	5	Polycarbonate	s	AF50P-050AS
AF800-12	SMC	1¼"	12.000	5	Polycarbonate	s	-
AF800-14	SMC	1½"	12.000	5	Polycarbonate	s	-
AF900-20	SMC	2"	20.000	5	Polycarbonate	s	-

Max. supply pressure: 1,0 MPa / Max. working pressure: 0,7 MPa / Temperature working area: -5 to 60° C.

On request

- Other combinations
- Automatic drain, normally opened (add C to order number). For good functioning, the drain line should have min. 8 mm diam. and can not be longer than 5 m
- Filtration 2, 10, 20, 40, 70, 100 μ
- Metal- or nylon bowls.

Polycarbonate bowls may be damaged and could possibly fail if they are exposed to synthetic oils, thinner solvents, trichloorethylene, kerosene and other aromatics hydrocarbons. If used in above atmosphere, please use a metal bowl (p.85).



AF

AFM- and AFD-series (modular)

AFM-series - microfilters

Type	Brand	Port size	NI/min	Filter micron	Bowl	Bowl with bajonet connection	Mounting brackets
AFM20-F02-A	SMC	1/4"	200	0,3	Polycarbonate	o	AF22P-050AS
AFM30-F02-A	SMC	1/4"	450	0,3	Polycarbonate	s	AF32P-050AS
AFM30-F03-A	SMC	3/8"	450	0,3	Polycarbonate	s	AF32P-050AS
AFM40-F03-A	SMC	3/8"	1.100	0,3	Polycarbonate	s	AF42P-050AS
AFM40-F04-A	SMC	1/2"	1.100	0,3	Polycarbonate	s	AF42P-050AS
AFM40-F06-A	SMC	3/4"	1.100	0,3	Polycarbonate	s	AF42P-070AS

Max. supply pressure: 1,0 MPa / Max. working pressure: 0,7 MPa / Temperature working area: -5 to 60° C.

AFD-series - submicrofilters

Type	Brand	Port size	NI/min	Filter micron	Bowl	Bowl with bajonet connection	Mounting brackets
AFD20-F02-A	SMC	1/4"	120	0,01	Polycarbonate	o	AF22P-050AS
AFD30-F02-A	SMC	1/4"	240	0,01	Polycarbonate	s	AF32P-050AS
AFD30-F03-A	SMC	3/8"	240	0,01	Polycarbonate	s	AF32P-050AS
AFD40-F03-A	SMC	3/8"	600	0,01	Polycarbonate	s	AF42P-050AS
AFD40-F04-A	SMC	1/2"	600	0,01	Polycarbonate	s	AF42P-050AS
AFD40-F06-A	SMC	3/4"	600	0,01	Polycarbonate	s	AF42P-070AS

Max. supply pressure: 1,0 MPa / Max. working pressure: 0,7 MPa / Temperature working area: -5 to 60° C.

On request

- Automatic drain, normally opened (add C to order number). For good functioning, the drain line should have min. 8 mm diam. and should not be longer than 5 m.
- Metal- or nylon bowls.

The microfilters do have an exceptional large air flow and a high rate of filtration. They remove more than 99,9% oil. The filter should be replaced if the decrease of air pressure is 1 bar or more.



AFM / AFD

Filter/Regulators

AW-series (modular)

AW-series - filter/regulators

Type	Brand	Port size	NI/min	Port size press. gauge	Working press. (Bar)	Filter micron	Bowl	Mounting nut	Bowl with bajonet connection	Mounting brackets
AW20-F02E	SMC	1/4"	500	Integrated	0,05 - 0,85	5	Polycarbonate	AR20P-260S	o	AW20P-270AS ¹⁾
AW30-F03E	SMC	3/8"	1.550	Integrated	0,05 - 0,85	5	Polycarbonate	AR30P-260S	s	AR30P-270AS ¹⁾
AW40-F04E	SMC	1/2"	2.800	Integrated	0,05 - 0,85	5	Polycarbonate	AR40P-260S	s	AR40P-270AS ¹⁾
AW40-F06E	SMC	3/4"	4.000	Integrated	0,05 - 0,85	5	Polycarbonate	AR40P-260S	s	AR40P-270AS ¹⁾
AW60-F10E	SMC	1"	9.000	Integrated	0,05 - 0,85	5	Polycarbonate	-	s	AW60P-270 AS ²⁾

¹⁾ Supplied with mounting nuts / ²⁾ Supplied with mounting screws / ³⁾ o = optional, s = standard
Max. supply pressure: 1,0 MPa / Max. working pressure: 0,7 MPa / Temperature working area: -5 to 60° C.



AW30 AW20

On request

- Automatic drain, normally opened (add CE for E in order number). For good functioning, the drain line should have min. 8 mm diam. and should not be longer than 5 m.
- Filtration 2, 10, 20, 40, 70, 100 μ.
- Metal- or nylon bowls.

Lubricators

AL-series (modular)

AL-series - lubricators

Type	Brand	Port size	NI/min	Lubricating from NI/min	Sight dome	Bowl	Bowl with bajonet-connection	Mounting brackets
AL20-F02-A	SMC	1/4"	1.550	15	AL20P-080AS	Polycarbonate	s	AF22P-050AS
AL30-F03-A	SMC	3/8"	3.100	30	AL20P-080AS	Polycarbonate	s	AF32P-050AS
AL40-F03-A	SMC	3/8"	7.800	40	AL20P-080AS	Polycarbonate	s	AF42P-050AS
AL40-F04-A	SMC	1/2"	7.800	40	AL20P-080AS	Polycarbonate	s	AF42P-050AS
AL40-F06-A	SMC	3/4"	7.800	40	AL20P-080AS	Polycarbonate	s	AF42P-070AS
AL50-F06	SMC	3/4"	10.000	190	AL20P-080AS	Polycarbonate	s	AF50P-050AS
AL50-F10	SMC	1"	10.000	190	AL20P-080AS	Polycarbonate	s	AF50P-050AS
AL60-F10	SMC	1"	14.000	220	AL20P-080AS	Polycarbonate	s	AF50P-050AS
AL800-12	SMC	1 1/4"	18.000	460	12316	Polycarbonate	s	-
AL800-14	SMC	1 1/2"	20.000	650	12316	Polycarbonate	s	-
AL900-20	SMC	2"	25.000	1.800	12316	Polycarbonate	s	-

o = optional, s = standard
Max. supply pressure: 1,0 MPa / Max. working pressure: 0,7 MPa / Temperature working area: -5 to 60°C / Recommended oil norm: ISO VG32



AL

AR-series (modular)

AR-series - regulators

Type	Brand	Port size	NI/min	Port size pressure gauge	Working pressure (bar)	Mounting nut	Mounting brackets
AR20-F02E	SMC	1/4"	500	Integrated	0,05 - 0,85	AR20P-260S	AR20P-270AS*
AR30-F03E	SMC	3/8"	2.800	Integrated	0,05 - 0,85	AR30P-260S	AR30P-270AS*
AR40-F03E	SMC	3/8"	4.300	Integrated	0,05 - 0,85	AR40P-260S	AR40P-270AS*
AR40-F04E	SMC	1/2"	4.300	Integrated	0,05 - 0,85	AR40P-260S	AR40P-270AS*
AR40-F06E	SMC	3/4"	4.300	Integrated	0,05 - 0,85	AR40P-260S	AR40P-270AS*
AR50-F06E	SMC	3/4"	7.000	Integrated	0,05 - 0,85	-	AR50P-270AS**
AR50-F10E	SMC	1"	7.000	Integrated	0,05 - 0,85	-	AR50P-270AS**
AR60-F10E	SMC	1"	9.000	Integrated	0,05 - 0,85	-	AR50P-270AS**
AR825-12	SMC	1 1/4"	14.000	R1/4	0,05 - 0,85	-	-
AR825-14	SMC	1 1/2"	14.000	R1/4	0,05 - 0,85	-	-
AR925-20	SMC	2"	18.000	R1/4	0,05 - 0,85	-	-

¹⁾ Supplied with mounting nuts / ^{**} Supplied with mounting screws
Max. supply pressure: 1,0 MPa / Max. working pressure: 0,7 MPa / Temperature working area: -5 to 60° C.



AR

AR-series - high pressure regulators

Type	Brand	Port size	NI/min	Port size pressure gauge	Working pressure (bar)	Mounting nut	Mounting brackets
AR40-F03-X425	SMC	3/8"	4.500	R1/4	0,05 - 1,50	AR40P-260S	AR40P-270AS*
AR40-F04-X425	SMC	1/2"	5.000	R1/4	0,05 - 1,50	AR40P-260S	AR40P-270AS*
AR60-F10-X425	SMC	1"	8.000	R1/4	0,05 - 1,50	-	AR50P-270AS**

¹⁾ Supplied with mounting nuts / ^{**} Supplied with mounting screws
Max. supply pressure: 1,0 MPa / Max. working pressure: 0,7 MPa / Temperature working area: -5 to 60° C.

Accessories spacers / brackets



Y100 spacer



Y100 spacer with bracket

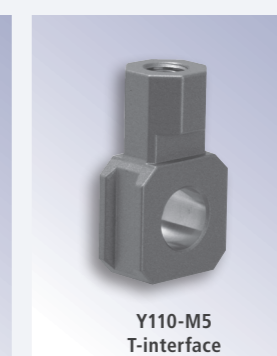

Y110-M5 T-interface

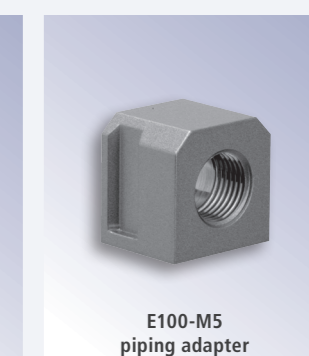

E100-M5 piping adapter

For series	Band	Port size	Piping adaptors	Spacer	Spacer with bracket	T-interface	Piping adapter
20	SMC	1/4"	E200-F02-A	Y200-A	Y200T-A	Y210-02-A	E200-F02-A
30	SMC	3/8"	E300-F03-A	Y300-A	Y300T-A	Y310-02-A	E300-F03-A
40	SMC	1/2"	E400-F04-A	Y400-A	Y400T-A	Y410-03-A	E400-F04-A
40	SMC	3/4"	E500-F06-A	Y500-A	Y500T-A	Y510-03-A	E500-F06-A
50	SMC	3/4"	E500-F06	Y500	Y500T	Y510-04	E500-F06
50	SMC	1"	E500-F10	Y500	Y500T	Y510	E500-F10
60	SMC	3/4"	E600-F06	Y600	Y600T	Y610-04	E600-F06
60	SMC	1"	E600-F10	Y600	Y600T	Y610	E600-F10

Piping adaptors for easy installation and maintenance

Spacers for mounting the combination without wall connection.

Spacers with T-type bracket for wall mounting the modular unit, equipped with T-type bracket.

Mounting brackets for mounting separate components.



Type	Brand	For series	Port size	Operation	NI/min	Silencer	Working pressure (bar)	Diameter mm
------	-------	------------	-----------	-----------	--------	----------	------------------------	-------------

EAD-series - automatic condensate drains

EAD202-F02	SMC	-	1/4"	Pneumatic	-	-	-	-
EAD202-F03	SMC	-	3/8"	Pneumatic	-	-	-	-
EAD402-F04	SMC	-	1/2"	Pneumatic	-	-	-	-
EAD600-F10	SMC	-	1"	Pneumatic	-	-	-	-
ADH4000-F04	SMC	-	1/2"	Pneumatic	-	-	-	-
ADM200-045	SMC	-	1/2"	Electric (220V)	-	-	-	-

AKM-series - T-type spacers with check valve

AKM2000-F02-A	SMC	20	1/4"	-	750	-	-	-
AKM3000-F02-A	SMC	30	3/8"	-	1.700	-	-	-
AKM4000-F03-A	SMC	40	1/2"	-	3.150	-	-	-

VHS-series - shut-off valves

VHS20-F02-A	SMC	20	1/4"	-	750	AN103-01	-	-
VHS30-F03-A	SMC	30	3/8"	-	1.700	AN200-02	-	-
VHS40-F04-A	SMC	40	1/2"	-	3.150	AN300-03	-	-

K-series - pressure gauges external

G27-10-R1	SMC	10	1/16"	-	-	-	0 - 1,0	26
K8-10-40	SMC	20/30	1/8"	-	-	-	0 - 1,0	40
K4-10-50	SMC	40/50/60	1/4"	-	-	-	0 - 1,0	50

GC-series - pressure gauges internal

GC3-10AS	SMC	20/30/40/50/60	1/16"	-	-	-	0 - 1,0 MPa	24
----------	-----	----------------	-------	---	---	---	-------------	----

ISE35-series - integrated pressure gauges with pressure switch and cable

Type	Brand	For series	Power supply	Cable length m	Protection degree	Display	Set pressure range	Output
ISE35-N-65-LA	SMC	20/30/40/50/60	12 - 24V DC	2	IP40	LED 2-colors	-0,01 - 1,0	NPN
ISE35-N-25-LA	SMC	20/30/40/50/60	12 - 24V DC	2	IP40	LED 2-colors	-0,01 - 1,0	PNP



For series	Brand	For lubricator	For filter	Polycarbonate	Nylon	Metal	Automatic drain	O-Rings
20	SMC	C2SL-A	C2SF-A C2SF-6-A C2SF-2-A AD27-A	*	*	*	*	C2SFP-260S
30	SMC	C3SL-A	C3SF-A C3SF-6-A C3SF-2-A AD37-A	*	*	*	*	C32FP-260S
40	SMC	C4SL-A	C4SF-A C4SF-6-A C4SF-2-A AD47-A	*	*	*	*	C4SFP-260S
50	SMC	C4SL	C4SF C4SF-6 C4SF-2 AD47	*	*	*	*	C42FP-260S
60	SMC	C4SL	C4SF C4SF-6 C4SF-2 AD47	*	*	*	*	C4SFP-260S

Polycarbonate bowls may be damaged and could possibly fail if they are exposed to synthetic oils, thinner solvents, trichloro-

ethylene, kerosene and other aromatic hydrocarbons. If used in above atmosphere, please use a metal bowl.

Refrigated air dryer

IDFA-series

The new SMC IDFA series of refrigerated air dryers are the result of over 40 years of experience combined with the latest compressed air and refrigeration technology. Built to international standards and backed by SMC's BS and ISO 9001 quality certification. The new IDFA series has ten standard models with nominal capacities ranging from 12 - 1.340 m³/h.

Series IDFA Refrigerated Air Dryer

- State of the art design ensures a constant +3°C pressure dew point
- High efficiency heat exchanger
- Environmentally ozone friendly refrigerants
- Conforms to stringent ISO8573-1 standards
- Simple control system with easy to read evaporator gauge
- Compact design for easy installation
- High performance, reliable and trouble free



IDFA series - standard specifications

Type	Brand	Inlet air-pressure (bar)	Inlet air-temp. (°C)	Ambient temp. (°C)	Power supply voltage	Power cons. W	Air port connections	Refrigerant	Weight kg
IDFA3E-23	SMC	0,15 - 1,0	5 - 50	2 - 40	1 Phase 230V AC 50Hz/60Hz	180	Rc 3/8	R134a	18
IDFA4E-23	SMC	0,15 - 1,0	5 - 50	2 - 40	1 Phase 230V AC 50Hz/60Hz	180	Rc 1/2	R134a	22
IDFA6E-23-K	SMC	0,15 - 1,6	5 - 50	2 - 40	1 Phase 230V AC 50Hz/60Hz	180	Rc 3/4	R134a	23
IDFA8E-23-K	SMC	0,15 - 1,6	5 - 50	2 - 40	1 Phase 230V AC 50Hz/60Hz	208	Rc 3/4	R134a	27
IDFA11E-23-K	SMC	0,15 - 1,6	5 - 50	2 - 40	1 Phase 230V AC 50Hz/60Hz	385	Rc 3/4	R134a	28
IDFA15E-23-K	SMC	0,15 - 1,6	5 - 50	2 - 40	1 Phase 230V AC 50Hz	470	Rc 1	R134a	46
IDFA22E-23-K	SMC	0,15 - 1,6	5 - 50	2 - 40	1 Phase 230V AC 50Hz	760	R 1	R407C	54
IDFA37E-23-K	SMC	0,15 - 1,6	5 - 50	2 - 40	1 Phase 230V AC 50Hz	760	R 1½	R407C	62
IDFA55E-23-L	SMC	0,15 - 1,6	5 - 50	2 - 40	1 Phase 230V AC 50Hz	1.130	R 2	R407C	100
IDFA75E-23-L	SMC	0,15 - 1,6	5 - 50	2 - 40	1 Phase 230V AC 50Hz	1.700	R 2	R407C	116
IDFA100F-40	SMC	0,15 - 1,0*	5 - 60	2 - 45	3 Phase 400V AC 50Hz	2.500	R 2	R407C	245
IDFA125F-40	SMC	0,15 - 1,0*	5 - 60	2 - 45	3 Phase 400V AC 50Hz	2.700	R 2½	R407C	270
IDFA150F-40	SMC	0,15 - 1,0*	5 - 60	2 - 45	3 Phase 400V AC 50Hz	2.700	DIN 80	R407C	350

* Also available with 0,15-1,6 MPa
Note: Thread adapters to convert Rc thread to R thread are included with IDFA3E to IDFA15E.

IDFA series nominal air flow rate [m³/h (ANR)]*

Type	Brand	3°C Pressure dew point	7°C Pressure dew point	10°C Pressure dew point
IDFA3E-23	SMC	12	15	17
IDFA4E-23	SMC	24	31	34
IDFA6E-23-K	SMC	36	46	50
IDFA8E-23-K	SMC	65	83	91
IDFA11E-23-K	SMC	80	101	112
IDFA15E-23-K	SMC	120	152	168
IDFA22E-23-K	SMC	182	231	254
IDFA37E-23-K	SMC	273	347	382
IDFA55E-23-L	SMC	390	432	510
IDFA75E-23-L	SMC	660	720	822
IDFA100F-40	SMC	860	-	-
IDFA125F-40	SMC	1.100	-	-
IDFA150F-40	SMC	1.340	-	-

* Standard condition (ANR) with 20°C ambient temperature, atmospheric pressure and relative humidity of 65%. Performance data for pressure dew point in accordance with operating conditions from ISO7183 (P1 = 7 bar, T1 = 35°C (saturated), cooling air temp. 25°C).

Dimensions IDFA-series

Type	A	B	C
IDFA3E-23	226	410	437
IDFA4E-23	270	453	498
IDFA6E-23-K	270	455	498
IDFA8E-23-K	270	485	568
IDFA11E-23-K	270	485	568
IDFA15E-23-K	300	603	578
IDFA22E-23-K	290	775	623
IDFA37E-23-K	290	855	623
IDFA55E-23-L	470	855	800
IDFA75E-23-L	470	855	900
IDFA100F-40	670	1.120	1.276
IDFA125F-40	700	1.120	1.276
IDFA150F-40	950	1.290	1.332

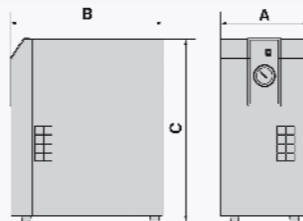

Refrigated air dryer

Funktionsprinzip

Operation principle IDFA refrigerated air dryer

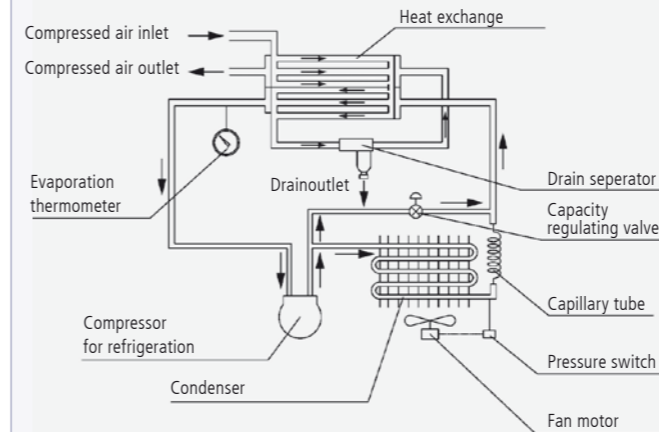

Saturated compressed air enters the air-to-air heat exchanger. The incoming air is then pre-cooled by the cold air exiting the dryer. The air then passes through the evaporator, where it is further cooled to 3°C dew point. As the air cools, the water condenses to liquid which is removed by the automatic drain. The dry air is then passed back through the air-to-air heat exchanger where it is reheated before leaving the dryer.

Banish moisture in your compressed air

Tests carried out by SMC, world leaders in pneumatic technology, have indicated that in certain atmospheric conditions the moisture contained in compressed air from a 75 kW compressor after one days operation could be equivalent to 113 litres of water.

Obviously any compressed air system containing this volume of air moisture will suffer from dramatically reduced valve and air cylinder performance. Therefore armed with this knowledge, SMC's R&D engineers have now produced the perfect answer with their new range of Refrigerated Air Dryers - Series IDFA.

Designed specifically for the European market, with both CE accreditation and 230V AC (50Hz) voltage requirements, Series IDFA effectively removes water vapour through a highly efficient stainless steel, improved corrosion resistant, heat exchanger. With 13 flow rate size options. 12 to 1.340 m³/h (ANR), these new air dryers use ozone friendly HFC refrigerants - R134a/R407C and emit outlet air at 3°C point as per ISO8573-1 standard.

Incorporating an easy to see evaporation temperature gauge, to confirm correct operation, Series IDFA is highly efficient with a low pressure drop when operating for improved energy savings.

IDFA3E-23 up to IDFA75E-23-L - correction factors

Inlet air temp. (°C)	Correction factor A	Ambient temp. (°C)				
		20°	25°	30°	35°	40°
5-25°	1,30	1,25	1,00	0,83	0,70	0,60
30°	1,10	1,00	0,91	0,83	0,79	
35°	1,10	1	0,97	0,89	0,77	
40°	0,80	0,87	0,92	0,96	1,00	1,04
45°	0,72	0,81	0,88	0,95	1,00	1,06
50°					1,11	1,16
					1,19	1,21
					1,21	1,23
					1,25	1,26
					1,27	

Corrected air flow rate [m³/h] = Customers air flow rate / (factor A x factor B x factor C)

IDFA100F-40 up to IDFA150F-40 correction factors

Correction factor A		Correction factor B		Correction factor C		Correction factor D		Air flow rate			
Inlet air temp. (°C)	Correction factor	Ambient temp. (°C)	Correction factor	Pressure dew point (°C)	Correction factor	Lufteinlasspunkt (MPa)	Correction factor	Model	IDFA100F	IDFA120F	IDFA150F
5 up to 30	1,41	2 up to 25	-	3	0,7	0,2	0,84	Air flow rate [m ³ /h(ANR)]	960	1.210	1.500
35	1,21	30	-	5	0,75	0,3	0,87				
40	1	32	1	10	1	0,4	0,9				
45	0,92	35	1	15	1,4	0,5	0,93				
50	0,75	40	0,99			0,6	0,96				
55	0,63	45	0,92			0,7	1				
60	0,53					0,8	1,03				
						0,9	1,06				
						1 bis 1,6	1,09				

Correction air flow rate [m³/h] = Air flow rate of the customer / Faktor A x Faktor B x Faktor C x Faktor D

Index

7VC-6500FS	38
7VC-8500FS	38
10RDS-2500	33
10RDS-4000	33
8130-1001-00-00	78
8130-1002-00-00	78

A

AA-OBR(H)	47
AA-1.3BR(H)17,5	47
AA-1.3BR(H)19x50	47
ATLUB	78

B

BRH-6	47
-------	----

E

EK-0	76
EK-00	76
ELB-30 (ELF-30)	76
ELF-3	76
ELF-5	76
ELF-9	76
ELF-15	76
ELF-22	76
ELF-40	76
ELF-50	76
ELF-60	76
ELF-70	76
ETP-14	76
ETP-15	76
ETP-16	76

F

F-25	47
F-25N	59

G

G-40EF	39
G-40RF	39
G-40SRF	39
G-50EF	39
G-50RF	39
G-70EF	39
GS-2EFS	38

H

HS-4	43
HTB-0	76
HTB-1	76

HTB-2	76
-------	----

K

KIT-100-KIT	77
-------------	----

M

MBC-30S	11
MD-10L	33
MD-3312B	33
MG-OA	37
MG-OC	37
MG-1B	37
MG-7206B	37
MG-7236B	36

MI-12	9
MI-16	9
MI-17HEG	9
MI-17HE/SETSTD	10
MI-17HE/SETLNG	10
MI-20P	9
MI-38ESR	11
MI-38ELR	11
MI-42ESR	11
MI-42ELR	11
MI-590TR	11
MI-1600	9
MI-3800PLR	9
MI-3800PR	9
MI-3800ELR	11
MI-3800ESR	11
MI-4500ELR	11
MI-4500ESR	11
MI-5500ES	11

MID-600	27
---------	----

MR-2207C	26
MR-2209C	26
MR-2310B	26
MR-2410B	26
MS-4125B	43

N

NOBP	78
------	----

P

PT-serie	77
----------	----

R

RR-025C	29
RR-025P	29
RR-065C	29
RR-065P	29
RR-0315	47
RR-0315NS	59
RR-10DP	33
RR-13DP	33
RR-15P	9
RR-20PN	9
RR-160H	9
RR-476	74
RR-0800DD	27
RR-1800DD	27
RR-2110NS	59
RRB-280	43

RRG-200RE	37
RRG-200REL	37
RRG-202T	37
RRG-500RE	37
RRG-500REL	37
RRG-1040AL	39
RRG-2034	39
RRG-2044	39
RRG-2055	39
RRG-2090	36
RRG-3611	45
RRG-3617K	45
RRG-3621	45
RRG-3630	45

RRH-2000	47
RRH-4210	47
RRH-4210K	47

RRI-BI217E	13
RRI-BI474E	13

RRI-BS3	32
RRI-BS6	32
RRI-BS9	32
RRI-BS12	32

RRI-G50	39
RRI-GT50F	39

RRI-SA10902	30
RRI-SA11602	30
RRI-SA20705	30

RRI-SA21104	30
RRI-SA21704	30
RRI-SA30511	30
RRI-SA30710	30
RRI-SA31108	30
RRI-SA30511W	30
RRI-SA30710W	30
RRI-SA31108W	30

RRI-SD10902	31
RRI-SD11602	31
RRI-SD20705	31
RRI-SD21104	31
RRI-SD21704	31
RRI-SD30511	31
RRI-SD30710	31
RRI-SD31108	31
RRI-SD31706	31

RRI-SL10902	31
RRI-SL11602	31
RRI-SL20705	31
RRI-SL21104	31
RRI-SL21704	31
RRI-SL30511	31
RRI-SL30710	31
RRI-SL31108	31
RRI-SL31706	31

RRI-SP10902	30
RRI-SP11602	30
RRI-SP20705	30
RRI-SP21104	30
RRI-SP21704	30
RRI-SP30511	30
RRI-SP30710	30
RRI-SP31108	30
RRI-SP31706	30

RRI-T1135	36
RRI-T1550	36
RRI-T1565	36
RRI-T3335	36
RRI-T3440	36
RRI-T3750	36
RRI-T4065	36
RRI-T5625	36
RRI-T6250-5NV	43
RRI-T6250-5CV	43

RRI-16N	9
RRI-18N	9

Index

RRI-18N/SETSTD	10
RRI-18N/SETLNG	10
RRI-18NT	9
RRI-21	9
RRI-24N	9
RRI-27P	9
RRI-36E	11
RRI-36P	9
RRI-1060	11
RRI-2006	33
RRI-2116P	33
RRI-2206/28	33
RRI-2206/40	33
RRI-3006	36
RRI-3007	36
RRI-3407	37
RRI-3425	37
RRI-3425L	37
RRI-3425EL	37
RRI-3430	37
RRI-3445	37
RRI-3506	36
RRI-4006	59
RRI-4006VL	59
RRI-4007	59
RRI-4007VL	59
RRI-4008	59
RRI-4010	73
RRI-4011	73
RRI-4596/1	47
RRI-4596R	47
RRI-4612K VL	47
RRI-4612R VL	47
RRI-5125-2NV	43
RRI-5125-2CV	43
RRI-5125-2SV	43
RRI-5125-5NV	43
RRI-5125-5CV	43
RRI-5125-5SV	43
RRI-6150-2NV	43
RRI-6150-2CV	43
RRI-6150-2SV	43
RRI-6150-5NV	43
RRI-6150-5CV	43
RRI-6150-5SV	43
RRI-8002	61
RRI-8003	61
RRI-8004	61
RRI-8011	61
RRI-8031	61
RRI-8032	61
RRI-8350	63

RRI-8460	62
RRI-8560	62
RRI-9001/1	76
RRI-9003/1	76
RRI-9005/1	76
RRI-9010	73
RRI-21930	73
RRI-34100	37

RRJ-8205	63
RRJ-8210	63

RRP-203	73
---------	----

RRS-60152	45
RRS-60153	45
RRS-60323	45

RRW-121	26
RRW-2202	26
RRW-2203	26
RRW-2403	26
RRW-2404	26
RRW-3403	26
RRW-3404	26

T

TAG-40FLH	39
TAG-45MLH	39
TAG-50MLH	39
TAG-700QJL	39
TAG-900QJL	39

TCD-20	47
TCR-125C	66
TCR-125DPE	66
TCR-250C	66
TCR-250DPE	66
TCR-250ME	66
TCR-500/2C	66
TCR-500/2DPE	66
TCR-600250 C/P	66
TCR-500 C/P	66
TCR-1000/2 C/P	66
TCR-1000 C/P	66
TCR-2000/2 C/P	66
TCR-3000 C/P	66
TCR-6000/2 C/P	66
TCS-500 C/PE	66
TCS-980/2 C/PE	66

V-160P	9
VMG11WF02	73
VOKIT-100	78

TDN-5D	69
TDN-6	69
TFC-200F	47
TFC-257H	47
TFC-N200	59

TH-5S	49
THA-2BRH19x50	47
THA-3BRH19x50	47
THA-4BRH19x50	47

TJ-15SBS	49
TJ-15SV LBS	49
TJ-15SV SBS	49
TJ-20SV LBS	49
TJ-20SV SBS	49

TMM-140AE	66
TPB-40	49
TPB-40SV	49
TPB-501SV	49
TPB-60	49

TSG-3L	38
TSG-4L	38
TSG-5L	38
TSG-6L	38

TW-3	76
TW-5	76
TW-9	76
TW-15	76
TW-22	76
TW-30	76
TW-40	76
TW-50	76
TW-60	76
TW-70	76

V

YD-3A	27
YD-4A	27
YD-5A	27
YD-5PHCA	29
YD-40PZ	27

Y

YD-400SCA	29
YD-600SZ	27
YD-670A-RF	27
YDP-13	35
YDP-20	35
YHR-33	69
YHR-33L	69
YK-2	59
YLa70A	15
YLa70E	15
YLa80A	15
YLa80E	15
YLa90E	15
YLa110E	15
YLa120E	15
YLa140E	15
YLT50A	15
YLT50E	15
YLT60A	15
YLT60E	15
YLT70A	15
YLT70E	15
YLT80E	15
YLT110E	15
YLT120E	15
YLT140E	15
YLT150	15
YNR-8F	69
YP-18	72
YP-35	72
YPP-1	72
YRD-6NBK	33
YRD-8NBK	33
YRD-10NBK	33
YRD-13NBK	33
YRW-6	26
YRW-8NS	26
YRW-10N	26
YW-6CL	9
YW-50C	10
YW-65C	10
YW-90C	10
YW-120C	10

This catalogue is a snapshot of our assortment. On

www.rami-yokota.com

we would like to inform you about the latest developments!