



PLARAD



Products & Services



Everything from a single source!

TiD-extra
Industrial Technologies d.o.o.

PLARAD

www.tid-extra.hr

Subject to amendment. We take no responsibility for printing errors or inaccurate information. Pictures similar to products.

Bolting Technology		4
Electric Nutrunners DE		6
Battery Nutrunners DA1		10
Pneumatic Nutrunners DP		12
Hydraulic Torque Wrenches MSX · MX-EC		16
Hydraulic Torque Wrenches FSX		22
Electric Hydraulic Power Packs XB · IQ · Dual Power · TAX		28
Hydraulic Tensioners		42
Manual Hydraulic Pumps		44
Hydraulic Torque Wrenches K		46
Hydraulic Torque Wrenches HPR		48
Pneumatic Hydraulic Power Packs X · IQ		50
ATEX Products		53
Plarad Measurement Instrumentation		56
Manual Torque Multipliers XVR · XVK		58
Bespoke models		60
Accessories		62
Services		64

Type of bolting case

Many physical characteristics affect the bolting joint. Furthermore these physical characteristics also influence the final resulting bolting joint.

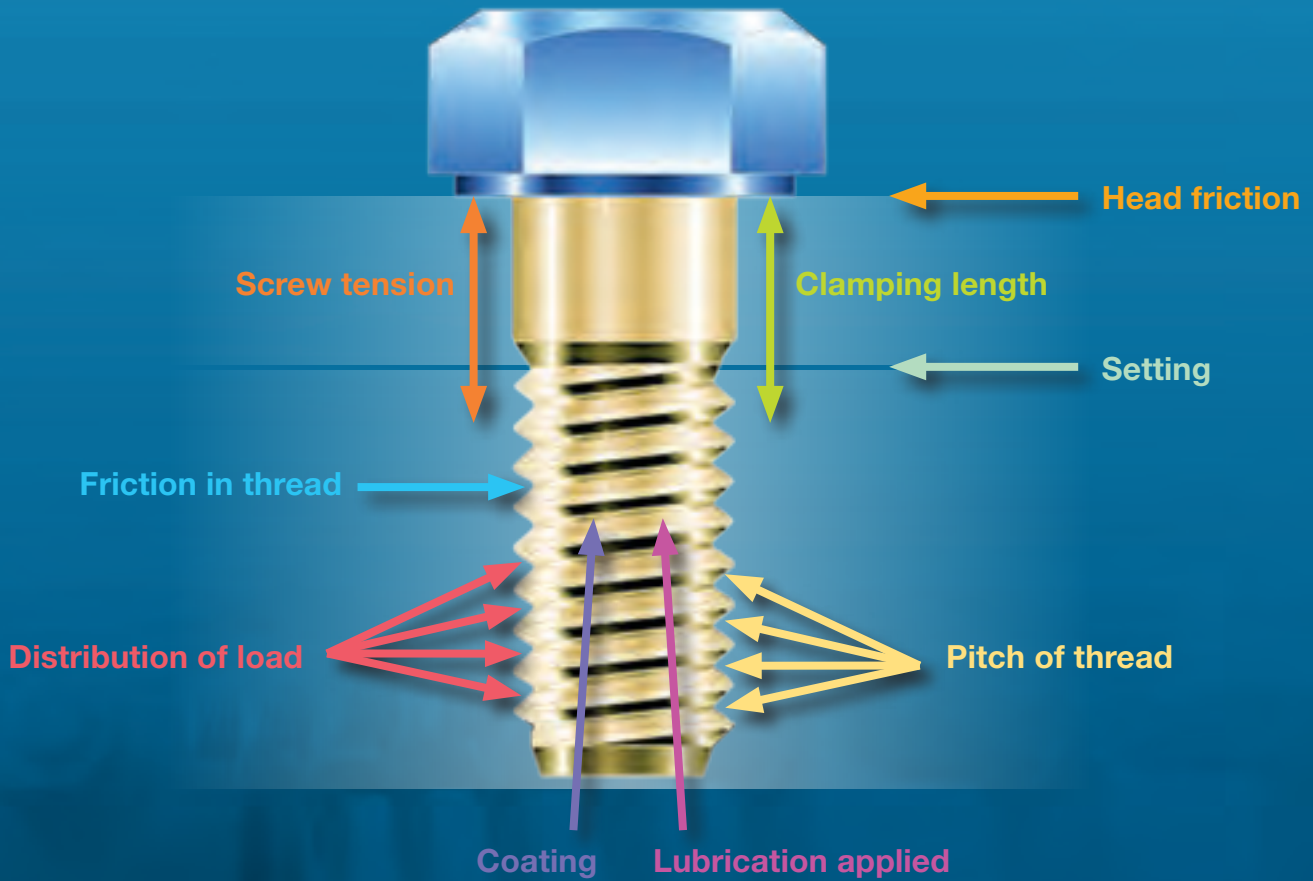

TiD-extra
Industrial Technologies d.o.o.



Our solutions

Only with precise processes and tools can safe bolting connections be achieved.

1

Torque-controlled tightening

- In the majority of cases where bolts are used, torque-controlled tightening is the method used to tighten.
- With this method the friction on the thread and head of the bolt act as a precise pre-tensioning force, therefore the use of accurate tools is imperative.
- Effectively the bolt can be tightened quicker.
- This method is more practical and easy.
- Light, compact tools can be used where space is limited.



2

Hydraulic pre-tensioning

- As the nut is not rotated under load, there is no torsional load on the bolt.
- After achieving the desired pre-tension, the nut can be tightened without causing stresses on it. The correct bolt pre-tensioning load is achieved.
- Even different co-efficient (levels) of friction have no effect on the tensioning process.



Via the hydraulic cylinder tensioning force is exerted on the bolt causing it to elongate.

3

Torque/torque-angle-controlled tightening

- Torque/torque-angle-controlled tightening is more precise than purely torque-controlled tightening.
- The defined amount of rotation of the bolt (torque angle) provides automatically and accurately the required pretension.
- Control is achieved directly from the power pack, by means of microprocessor technology within the pump.
- Higher quality bolting joints are achieved.
- Results can be stored and used at a later date for documentation required in quality assurance processes.
- The whole control process is achieved without the need of external sensors, hence no need for extra cables from the tool.

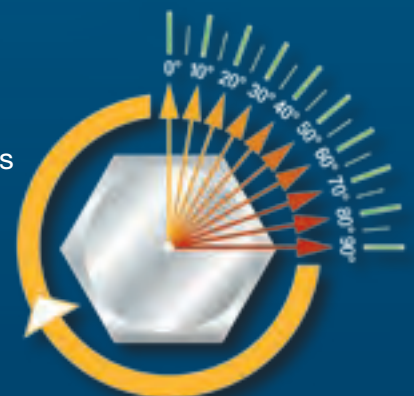



TiD-extra
Industrial Technology d.o.o.

PLARAD

DE – electric



Torque ranges up to 12,000 Nm

- For continuous use in assembly, maintenance and production.
- Electric nutrunner technology developed by Plarad has led to the creation of innovative top-quality products, including the Plarad DEM with a manual 2-speed gearbox and the Plarad DEA with an automatic two-speed gearbox.
- The low-vibration technology protects the operator's muscles and joints, effectively preventing the development of HAVS (Hand-Arm Vibration Syndrome).
- The extremely light weight and sophisticated ergonomic profile ensure ease of use.

DE Accessories

DE with angle drive: easy to use even in otherwise inaccessible places thanks to its low height. The electric motor and handle freely rotate on the gearbox.

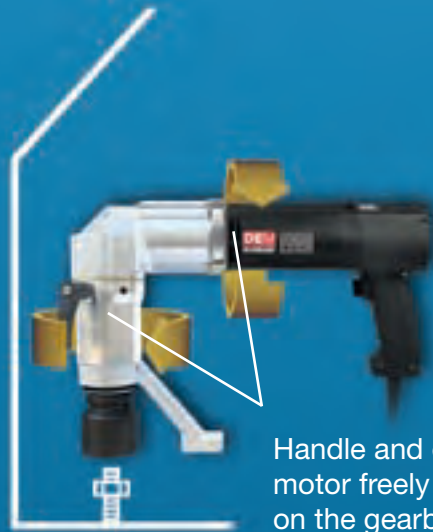

Handle and electric motor freely rotate on the gearbox (greater than 360°)

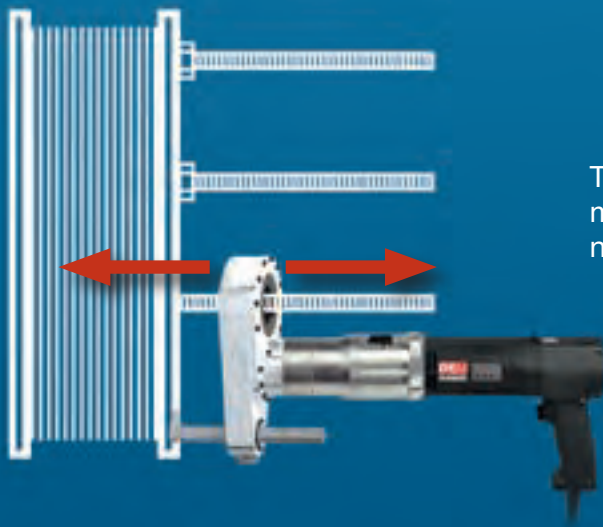

The offset gear makes it possible to move the wrench down long threads for nut sizes up to AF 150 mm.



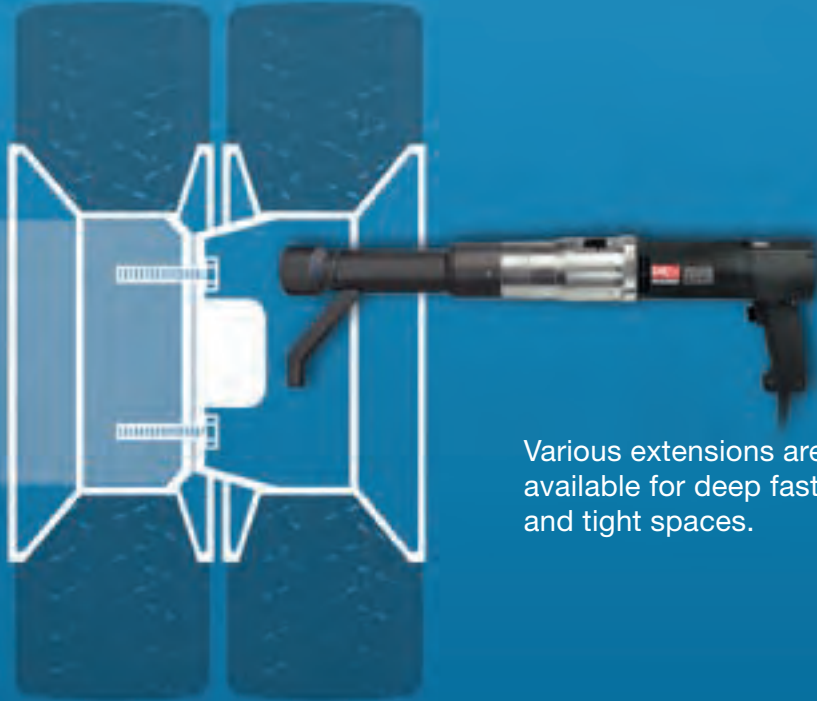

Various extensions are available for deep fastenings and tight spaces.

Type	Performance range (Nm)
------	------------------------

DEA/DEM 08	up to 800
DEA/DEM 12	up to 1,200
DEA/DEM 17	up to 1,700
DEA/DEM 28	up to 2,800
DEA/DEM 47	up to 4,700
DEA/DEM 65	up to 6,500
DEA/DEM 80	up to 8,000
DEA/DEM 120	up to 12,000



DA1 – Battery Nutrunner



Type	Performance range (Nm)
DA1-05	100 - 550
DA1-10	160 - 1,000
DA1-13	160 - 1,300
DA1-30	170 - 3,000
DA1-47	500 - 4,700

TiD-extra
Industrial Technologies d.o.o.



Torque range up to 4,700 Nm

- The range topping (most powerful) model DA1-47 can achieve up to 4,700 Nm
- 60 different torque settings
- Four different extrapowerful loosening settings
- Linear torque characteristics
- Two step active charge indicator
- On/Off operation trigger with delayed action – 0/1 binary logic
- Automatic release of forces on reaction arm once controlled tightening is achieved, no jamming



Predetermined torques can be set via changing the gear and setting the power setting step



Includes two 4,0 Ah lithium ion battery packs

High speed combined with enormous safety

As soon as the desired set torque value is acquired the unit automatically stops, it is also immediately ready for the next bolt tightening etc.

The continually active 2 step LED display of the battery charge prevents inaccurate torque tightening's when the capacity of the battery is too low.

The operation trigger is not variable but binary – thus preventing an inaccurate torque being applied, especially useful during extended operation or when wearing gloves.



Fast Charger





TiD-extra
Industrial Technologies d.o.o.

PLARAD

DP – pneumatic

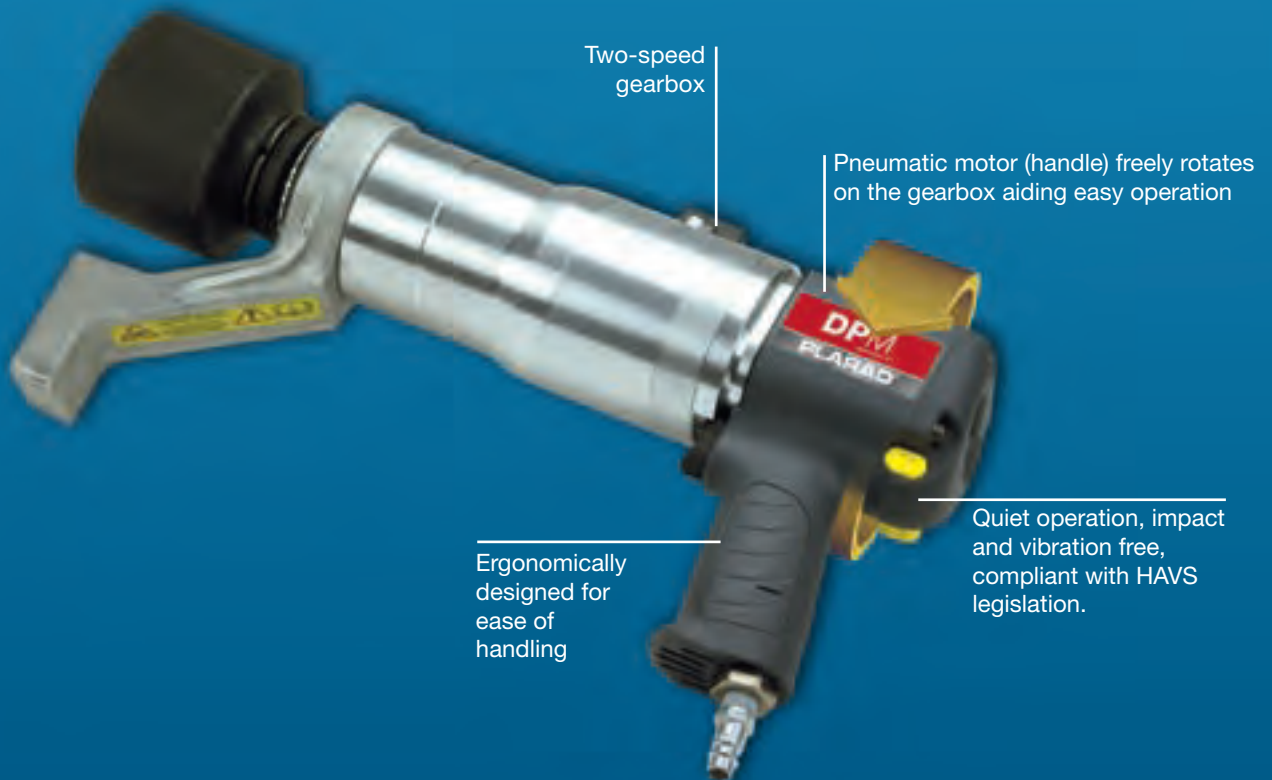

Torques of up to 12,000 Nm

- For continuous use in assembly, maintenance and production.
- Plarad pneumatic nutrunners are specifically designed for a variety of tasks, including “Ex” environments prevalent in the oil, gas, mining industry.
- Plarad DPM with manual 2-speed gearbox and Plarad DPA with automatic two-speed gearbox.
- The low-vibration technology protects the operator’s muscles and joints, effectively preventing the development of HAVS (Hand-Arm Vibration Syndrome).
- Their extremely light weight and sophisticated ergonomic profile enables ease of use.

DP Accessories

DP with angle drive: easy to use even in otherwise inaccessible places thanks to its low height. The pneumatic motor and handle freely rotate on the gearbox.



Handle and pneumatic motor freely rotate on the gearbox (greater than 360°)

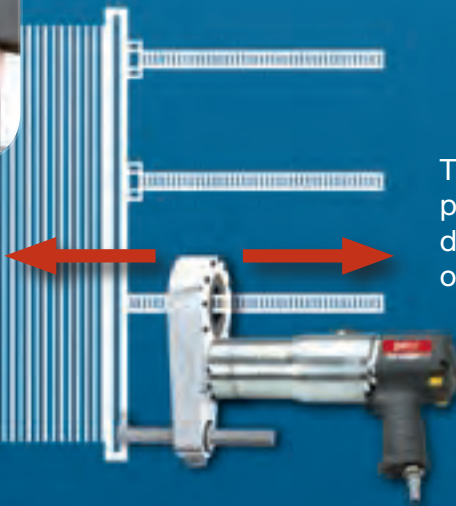

The offset gear makes it possible to move the wrench down long threads for nut sizes of up to AF 150 mm.



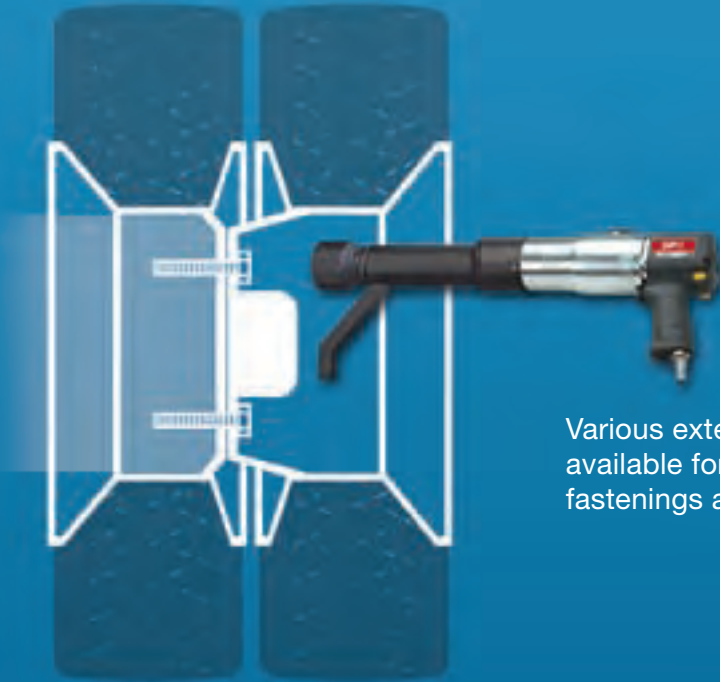

Various extensions are available for deep fastenings and tight spaces.

Fine adjustment is achieved via a pressure regulation unit



Type	Performance range (Nm)
DPA/DPM 08	up to 825
DPA/DPM 12	up to 1,220
DPA/DPM 17	up to 1,750
DPA/DPM 28	up to 2,850
DPA/DPM 47	up to 4,700
DPA/DPM 65	up to 6,500
DPA/DPM 80	up to 8,000

Up to 12,000 Nm available on request.





MSX, MX-EC – powerful and variable!



Continuous rotation in
every stroke position!
No jamming!

- Long-lasting Plarad quality.
- Fast operation thanks to optimum harmonisation with Plarad power packs.
- Safety relief valve.
- SQS-high-pressure safety cylinder – in case of housing fraction no leakage.
- Easy servicing.
- Compact dimensions.
- Fine-toothed ratchet system offers high torque precision and prevents jamming.
- Also available in an ATEX version (II 2 G ck II B T4) for Zone 1G.
- Internationally patented technology.

Precision and safety for each bolting case



The fast-locking device allows quick and simple reversing of the tool and socket



Available with adjustable handle



360° rotatable hose connection, with swivel option



Also available in a singlehose version – for even easier handling and positioning

Type	Square socket adapters	Torque range (Nm)
MX-EC 20 TS	1" and 3/4"	210 - 2,100
MX-EC 45 TS	1"	450 - 4,500
MX-EC 75 TS	1 1/2"	750 - 7,500
MX-EC 95 TS	1 1/2"	950 - 9,500
MX-EC 120 TS	1 1/2"	1,200 - 12,000
MX-EC 155 TS	1 1/2"	1,550 - 15,500
MX-EC 200 TS	2 1/2"	2,000 - 20,000
MSX 250 TS	2 1/2"	2,500 - 25,000
MSX 400 TS	2 1/2"	4,000 - 40,000
MSX 650 TS	3 1/2"	6,500 - 65,000



The reaction arm can be rotated quickly and easily through 360°. The safety latch reliably prevents inadvertent unlocking and potential fall to the ground.

Lever piston system – in the case of sudden loosening, the piston separates from the lever and reconnects automatically. No part is therefore in danger of being broken.

Extremely slim, lightweight and high-strength aluminium housing.

Pressure safety valve.

Safety ratchet – prevents unintended unlocking of the reaction arm.

Integrated release shock absorber protects the housing from sudden loosening impact damage.

Long-lasting fine-toothed ratchet system. Full stroke movement is not always essential.

The connection between lever and ratchet guarantees optimum transfer of the torque generated.

SQS safety cylinder made of high-strength material allows high pressures in a lightweight housing.

TiD-extra
Industrial Technologies d.o.o.



PLARAD

A comprehensive range of accessories allows for a large number of different applications

Standard square-drive sockets are available in all dimensions and for all across flats sizes.



Double hexagonal socket

Long socket

Reduction of height and weight through the use of one-piece splined safety sockets.



Splined safety hex inserts in a variety of sizes.





TiD-extra
Industrial Technologies d.o.o.



PLARAD



FSX – slim and precise!



Continuous rotation in
every stroke position!
No jamming!

- Long-lasting Plarad quality.
- Fast operation thanks to optimum harmonisation with Plarad power packs.
- Safety relief valve.
- SQS-high-pressure safety cylinder – in case of housing fracture no leakage.
- Easy servicing.
- Compact dimensions.
- Fine-toothed ratchet system offers high torque precision and prevents jamming.
- Also available in an ATEX version (II 2 G ck II B T4) for Zone 1G.
- ANSI/API-compatible version available.
- Internationally patented technology.

For tight spaces and inaccessible surroundings



Available with adjustable handle



360° rotatable hose connection, with swivel option



ANSI

Also available in an ANSI version for the oil & gas industry

FSX combination	Ratchet heads (AF)	Torque range (Nm)
SX-EC 1 / HSX	27 - 41	100 - 1,000
SX-EC 2 / HSX	20 - 70	250 - 2,500
SX-EC 5 / HSX	27 - 85	500 - 5,500
SX-EC 8 / HSX	46 - 80	800 - 8,500
SX-EC 12 / HSX	50 - 120	1,200 - 12,000
SX-EC 20 / HSX	55 - 145	2,000 - 20,000
SX 30 TST / HSX	95 - 145	3,000 - 30,000
SX 45 TST / HSX	120 - 185	4,500 - 45,000



SX drive unit

HSX ratchet head



Lever piston system – in the case of sudden loosening, the piston separates from the lever and reconnects automatically. No part is therefore in danger of being broken.

Extremely slim profile, lightweight high-strength aluminium housing.

Pressure safety valve.

Integrated release shock absorber protects the housing from sudden loosening impact damage.

SQS safety cylinder made of high-strength material allows high pressures in a lightweight housing

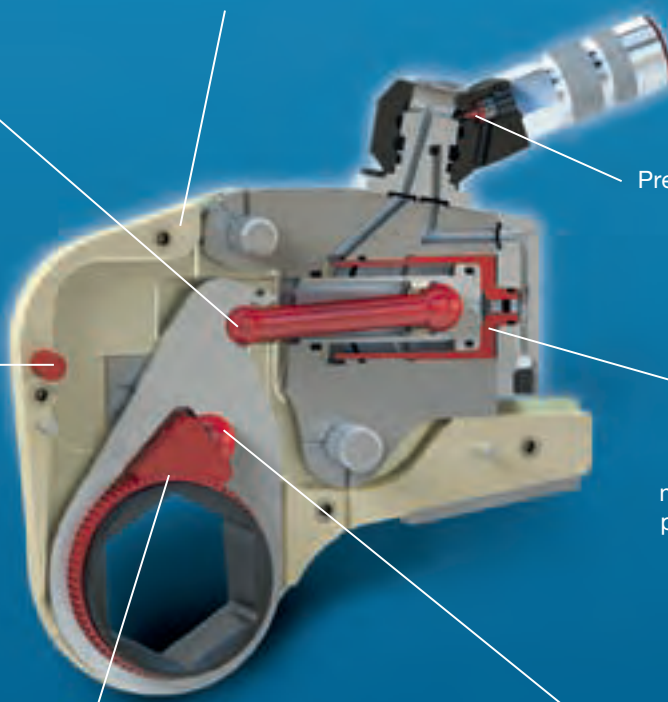

Long-lasting fine-toothed ratchet system. Full stroke movement is not essential.

The connection between lever and ratchet guarantees optimum transfer of the torque generated.

TiD-extra
Industrial Technologies d.o.o.



Also available in single hose version - for even easier handling



PLARAD

A comprehensive range of accessories enables many different applications

Interchangeable sockets in different sizes can be quickly changed.



In/out sockets are available in all dimensions and for all wrench sizes.



In exceptional cases, bespoke reaction arms can be designed to match your particular application, ensuring safe and optimum use of the reaction arm against a surface.



PLARAD



TiD-extra
d.o.o.



PLARAD

Electric Power Packs

TiD-extra
Industrial Technologies d.o.o.



Fast

- More bolts can be tightened in the same amount of time: Plarad products are up to 3 times faster than other products.

Reliable

- Accurate, safe results as the application is controlled and monitored completely automatically by an internal microprocessor.

Safe

- The Plarad documentation system makes it possible to record and illustrate the results of every bolting joint. For this reason the documentation is very useful in the field of product liability.

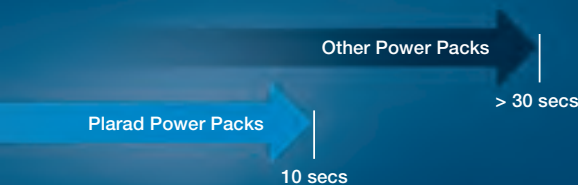

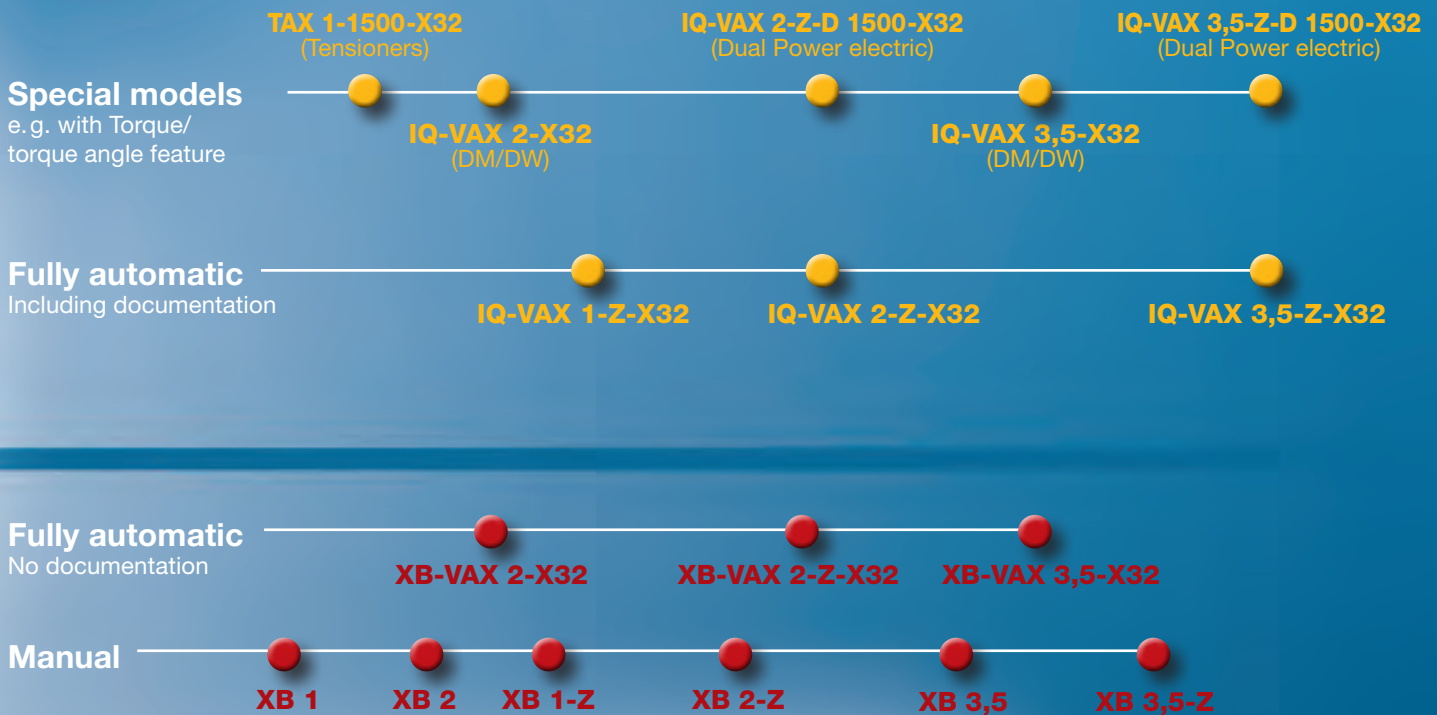

Fast operation

Lightweight

- Optimal power to weight ratio. The oil-filled electrical motor technology guarantees optimum weight and maximum output.



Can be operated almost continuously

- The power packs do not over-heat thanks to their special oil-filled motor design. The oil tank is part of the motor itself and no other tank is necessary. The motor, the pump unit and the oil are all cooled at the same time.



It runs and runs and runs!

- Innovative, patented technologies and design features, plus the use of high-quality materials ensure the pump has an extremely long lifespan.



For example, the equipment has been used in wind power construction/ service for more than 9 years.



TiD-extra
d.o.o.

PLARAD

XB Power Packs – setting high standards



XB 1

- The lightweight design of the XB 1 makes this powerhouse of a power pack ideal for mobile service applications.

XB 2

- The all-rounder in the XB range is the XB 2, famous for its high speed.

XB 3,5

- As the quickest power pack the XB 3.5 is a powerful package particularly suitable for complex bolting jobs.

Guide to wind the cables around

Rugged industrial cage for tough environments

800 bars

The Main Valve is within a protected non exposed area on the pump

Outward-facing oil filters (on XB 1 and XB 3.5) and maintenance friendly design, for easier maintenance

Improved valve technology

One or more hydraulic tools can be used with one or twin hose technology



PLARAD

Power Pack	Flow rate	Weight *
XB 1	0.8 l/min	20 kg
XB 2	1.2 l/min	29 kg
XB 3,5	3.5 l/min	33 kg
XB 1-Z	5.4 / 0.8 l/min	24 kg
XB 2-Z	8.0 / 1.2 l/min	31 kg
XB 3,5-Z	13.2 / 3.0 l/min	35 kg
XB-VAX 2	1.2 l/min	32 kg
XB-VAX 2-Z X32	8.0 / 1.2 l/min	32 kg
XB-VAX 3,5	3.5 l/min	35 kg

Extract from technical data (values apply to 230 V/50 Hz or 400 V/50 Hz versions. (Other voltages are available), e. g. 110 V.

* ready for use



XB 1

for mobile service work

XB 2

for universal use

XB 3,5

for use in manufacturing plants





TiD-extra
Industrial Technologies d.o.o.

PLARAD

Power Packs – high-tech models



Our rugged and durable power packs are characterised by the constant volume they output right up to their pressure limits, and have proved themselves through their long life in the toughest applications. The oil-filled motors prevents overheating. The design also ensures optimum performance to weight ratio.

IQ-VAX

- Fully automatic for accurate, reliable bolting joints.
- Documentation
- Instrumentation and control systems
- Torque-angle method

Each individual Bolting case (tightening – loosening) is controlled via the pumps microprocessor control unit utilising different processes

Fully automatic VAX technology keeps users perfectly safe

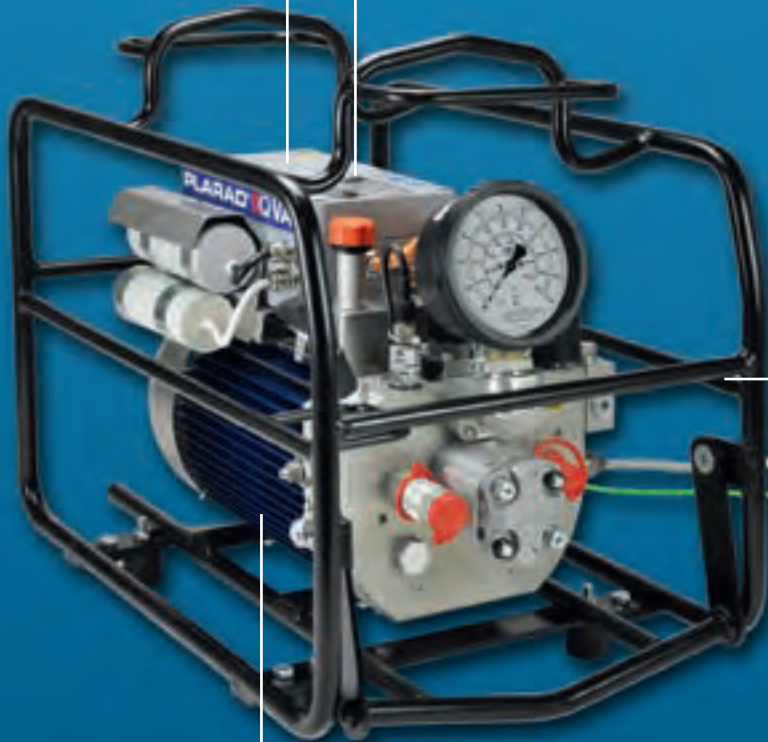

Rugged cage which protects the unit, even on building sites

Pressure indication displayed, assessment of the bolting case via a status indicators

Low noise whilst operating

Power Pack	Flow rate	Weight *
IQ-VAX 3,5-X32	3.5 l/min	35 kg
IQ-VAX 1-Z-X32	5.3 / 0.75 l/min	26 kg
IQ-VAX 2-Z-X32	8.0 / 1.2 l/min	32 kg
IQ-VAX 3,5-Z-X32	13.2 / 3.0 l/min	36 kg

Extracts of the specifications.

* ready for use



VAX – Genuine full automation function

- Straight to work at the touch of a button: the VAX Automatic controls and finishes the bolting joint automatically and accurately, even when handling multiple bolts, as well as indicating progress to the operator via the remote-control.
- Pressure is taken off the operator, hence errors are eliminated.



Documentation

- The Plarad “Documentation” add-on saves all torque or torque angles conducted into the control unit.
- Once uploaded to a computer, the bolting data can be used for traceability purposes on each bolt joint.



Multiple bolting technology's

- The Torque-Angle function, for example, means that differing friction coefficients of bolts no longer play a role. The required tightening torque will always be achieved.

Synchronised operation

- Synchronised operation using two or more units (MX-EC or FSX).
- The Automatic function ensures that synchronised bolting joints are handled quickly and reliably, ensuring an optimal seal.

Optional accessories



Examples include digital remote control, pressure and status indication



There is an extensive range of accessories, e.g. auxiliary oil tanks, to extend the unit's range of applications

TiD-extra
Inovativna Tehnologija



PLARAD

iQ[®] - Dual Power

The IQ Dual Power Pack can power both hydraulic torque tools and hydraulic tensioners.



Hydraulic Torque Tool

Power Pack	Flow rate	Weight *
IQ-VAX 2-Z-D 1500-X32	8.0 / 1.2 l/min (at 800 bar) 8.0 / 0.4 l/min (at 1500 bar)	40 kg
IQ-VAX 3,5-Z-D 1500-X32	13.2 / 3.0 l/min (at 800 bar) 13.2 / 1.0 l/min (at 1500 bar)	42 kg

Extracts of the specifications.

* ready for use

800 bars



1500 bars
(optional up to 2100 bars)



Tensioner

2-in-1

As well as a variety of bolting techniques and lifting processes in 800-bar mode, the Dual Power VAX unit can also be used for tensioning applications up to 1500 bars (optional up to 2100 bars). This universal hydraulic Power Pack saves you having to invest in additional high-pressure units.

- 2-in-1, one less unit to buy.
- Fully automatic pumping of hydraulic tensioners.
- Automatic limit-stop.
- Pumping performance accross the range.
- User-friendly – a remote control with identical functions. Users can easily familiarise themselves with the operation of the units easily.
- All of the upgrade's and enhancement's on conventional IQ Power Packs are also available for the Dual Power.

Controlled tensioning force in tensioner mode

When initially tensioning, there is a risk that oil pressure decreases due to the settling of the object during the actual stretching process or due to stretching of the attached hydraulic hoses.

Plarad IQ Power Packs Tensioner mode monitors the pressure and pump as required, ensuring that the required tension is achieved.

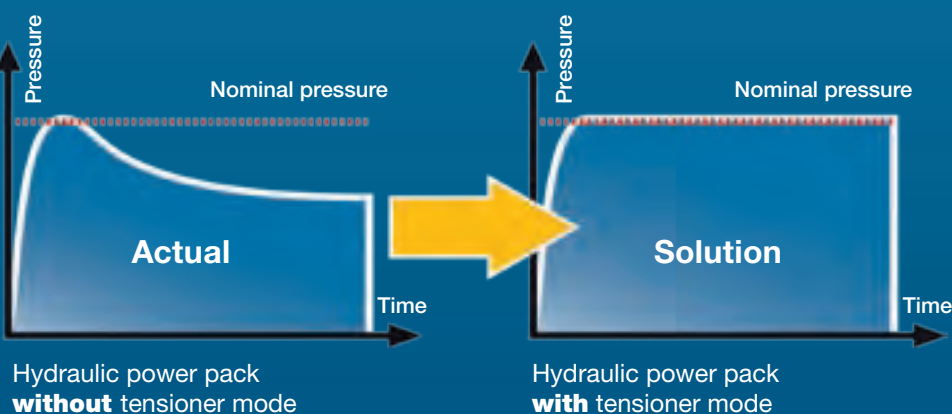

TAX – the pump for tensioners

Guide to wind the cables around



Power Pack	Flow rate	Weight *
TAX 1-1500-X32	0.4 l/min (1500 bar)	31 kg
TAX 3,5-1500-X32	1.0 l/min (1500 bar)	40 kg

Extracts of the specifications.

* ready for use

- Dedicated pump specially for tensioning applications up to 1500 bar (optional to 2100 bar)
- Pressure indication in the display screen
- Compactly built with special principles being utilised to build up the pressure



- Frictionless installation and disassembly from bolts/studs without exerting any torsional load on the bolt/stud
- Pre-tensioning force can be precisely set
- Individually adaptable to perfectly fit your specific joint/flange
- Available in single-stage and multi-stage configurations
- 1,500 bar maximum operating pressure
- Available in a variety of sizes



Single stage design for situations whereby the area around the axis is cramped

Hydraulic Tensioners

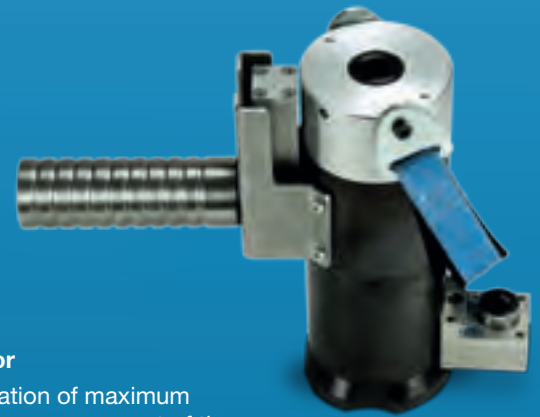

Safety indicator – green (optional)

Safe controlled operation: Verification of sufficient engagement of the bolt/stud.

Maximum stroke indicator

Optical safety: Visual indication of maximum stroke (max distance piston can move out of the tensioner body).

Cycle counter

The cycle counter indicates number of cycles performed and will consequently indicate the maximum cycle service point, thus avoiding damage and failures via preventive maintenance.

Automatic piston return

Swift operation: The puller is automatically returned to its original position once the pressure has been released.

Stroke limiter – mechanical

Ultimate safety: The mechanical end stop prevents the over extension of the piston (even under maximum load).

Rotating socket – spring-loaded

Prevention of installation damage during the positioning of the tensioner: The spring affords the rotating socket axial flexibility.

Stainless steel handle

Safety: Protection of the hose couplings against damage. Optimal grip and dexterity provided by the detachable handle of the tensioner.

Free Rotating Bridge

Exceptional handling: Straightforward alignment, independent of the bolt configuration.

Gearbox

Unique ease of use: The nut can be turned swiftly and with perfect ease using a ratchet or a torque wrench that is driven by a gear drive (maximum input torque: < M36=40 Nm, > M36=80 Nm).

Supporting surface – optimized

Outstanding versatility in any environment: The tensioner is especially well suited for use in tight spaces thanks to its optimal shape.



PLARAD

Hydraulic Pump – extremely light



Plarad's manual hydraulic Power Packs are characterised by their high performance and low weight.

The use of very rigid light metal saves more than 50% in weight compared to conventional steel pumps. 35 % less power required to achieve mechanical leverage, extremely low weight, and considerably higher pumping performance than conventional products, means that PH Power Packs are a welcome tool for everyday use in the workplace. Plarad PH Power Packs are also available in a variety of sizes.

- For occasional use
- Ideal for tensioners
- Extremely light
- High throughput
- More than 50% lighter than conventional steel pumps
- High throughput thanks to clever design
- Low setting down to 385 N
- Pressure limiting valve adjustable from the outside
- Carrying handle and stabilising feet
- Available with two sizes of tank, 2 l and 4 l
- Available in 800-bar and 1600-bar models



PLARAD

K – universal



- Universal torque tool for extremely cramped spaces

Ratchet heads (up to 105 mm) with exchangeable inserts

Socket fittings up to 150 mm, also available open and open-able versions



TiD-extra
 Industrial Technologies d.o.o.

Type	Head sizes (mm)	Performance range (Nm)
K 30 TF	24 - 95	300 - 3,000
K 60 TF	24 - 95	660 - 6,600
K 150 TF	27 - 110	1,100 - 11,000
K 200 TF	60 - 135	2,000 - 20,000
K 300 TF	80 - 150	3,000 - 30,000



PLARAD



HPR – 150,000 Nm!

- For doing up and undoing large, heavy bolting joints.
- Optimised for use in confined spaces where conventional hydraulic wrenches do not fit.
- The space required by a ring spanner is enough room for the HPR to operate.



Various ring spanner attachments, and the ratchet heads, can be changed quickly and easily.



CTK 3.5 EFS
Hydraulic Power Pack

Power unit	Performance range	Max. size, metric (SW)	Max. size, imperial (AF)	Weight
RE 500	5,000 to 50,000 Nm	185 mm	7 1/4"	34 kg
RE 1000	10,000 to 100,000 Nm	230 mm	9 1/8"	45 kg
RE 1500	15,000 to 150,000 Nm	320 mm	12"	76 kg



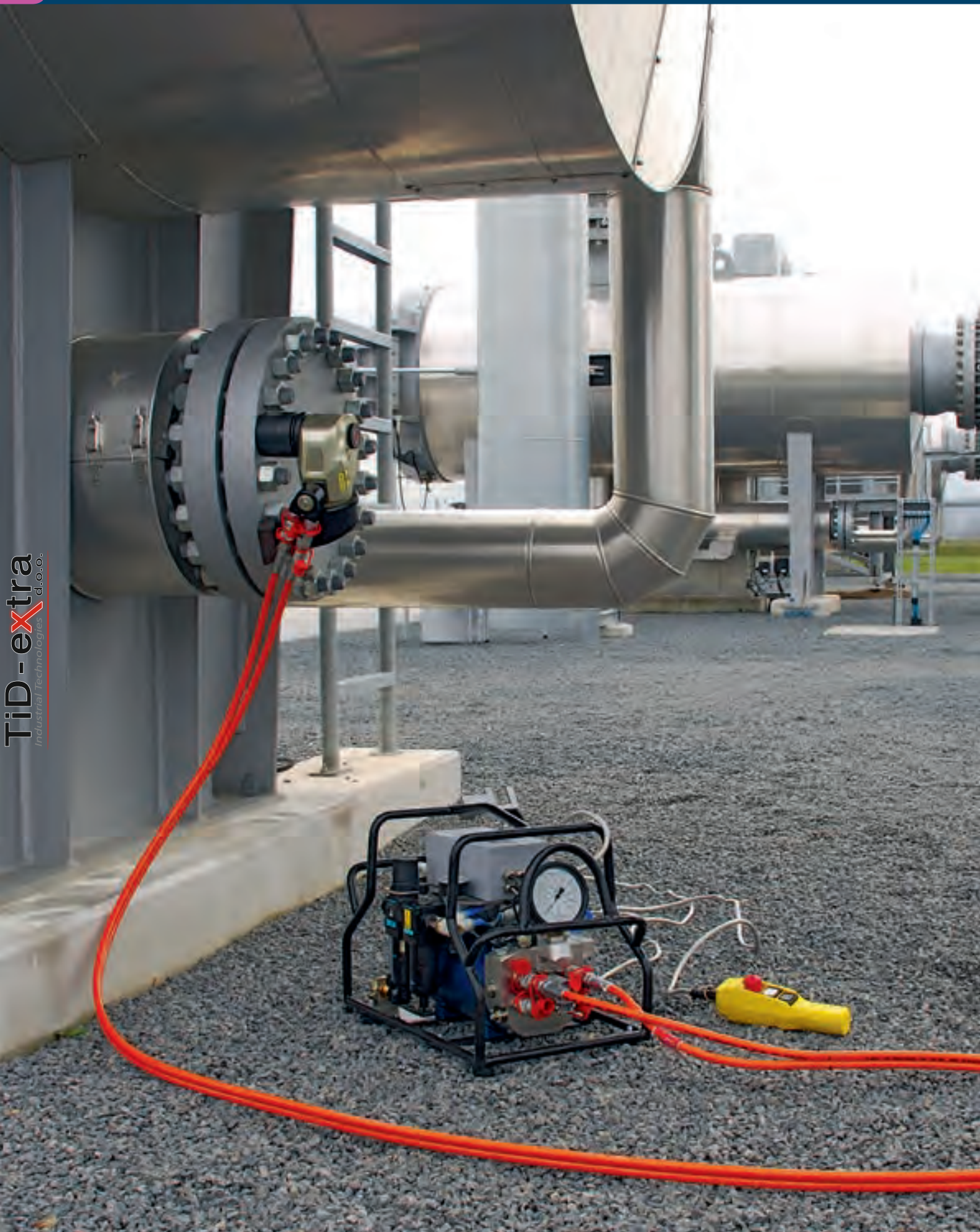

Pneumatic Power Packs



Just like our electrically powered hydraulic units, our pneumatic hydraulic power packs are characterised by their ruggedness, long life and their constant throughput right up to their pressure limits. The pneumatic motor is integrated into the oil tank, preventing seizure while simultaneously cooling the hydraulic fluid.

IQ VAX pneumatic

Only from Plarad!

The first pneumatic VAX unit: The new, fully automatic pneumatic power pack uses the latest microprocessor technology. This eliminates user errors since operators simply start a fully automatic, controlled procedure at the push of a button. The machinery shuts off automatically when the required torque is achieved and informs the operator via the remote control.



TiD-extra
Industrial Technologies d.o.o.



IQ-VAX 2 P-Z



For the full
functionality of
IQ technology

Power Pack	Flow rate	Weight *
X 1-P	0.8 l/min	24 kg
X 2-P	1.6 l/min	31 kg
X 2-P-Z	7.0 / 1.6 l/min	31 kg
X 2-P-Z ATEX	7.0 / 1.6 l/min	32 kg
IQ-VAX 2-P-Z	7.0 / 1.6 l/min	35 kg

Extracts of the specifications.

* ready for use

ATEX approved

Only from Plarad!

Pneumatic Hydraulic pump which is ATEX compliant

X 2 P-Z ATEX: Approved for operation in Zone 1G
Certified for use in areas containing materials with a
minimum flame point of 0,082 mJ



X 2 P-Z

Also available
in an
ATEX version!





PLARAD

ATEX products

Terminology conforms to EU machine guidelines 98/37/EU and 94/9 EU



X 2 P-Z
Pneumatic Power Pack

II 2G ck IIB T4
-10°C ≤ Ta ≤ +50°C



FSX
Hydraulic Torque Wrench

II 2G ck IIB T4
-10°C ≤ Ta ≤ +50°C



MX-EC
Hydraulic Torque Wrench

II 2G ck IIB T4
-10°C ≤ Ta ≤ +50°C



DP
Nutrunner (pneumatic)
for oil and gas industries

II 2GD c IIB T5
-10°C ≤ Ta ≤ +50°C



DP
Nutrunner (pneumatic)
for mining

I M2 c
-10°C ≤ Ta ≤ +50°C

PLARAD

Checking bolting joints

The microprocessor controlled GMV 2 unit is our key test instrument. Used in conjunction with a transducer, it enables precision measurement of torque while bolts are being done up. The values can be saved, along with the date and time, and can then be printed out by the instrument itself or uploaded to a PC for further evaluation.



TiD-extra
Industrial Technologies d.o.o.



Vezredungazna	Drum	Tet	Skrivitel	Merna	Sistim	Mikser	Maksimal	Sob	Evidencija	Vrijeme
1	10.2000	10.2000	10.2000	10.2000	10.2000	10.2000	10.2000	10.2000	10.2000	10.2000
2	10.2000	10.2000	10.2000	10.2000	10.2000	10.2000	10.2000	10.2000	10.2000	10.2000
3	10.2000	10.2000	10.2000	10.2000	10.2000	10.2000	10.2000	10.2000	10.2000	10.2000
4	10.2000	10.2000	10.2000	10.2000	10.2000	10.2000	10.2000	10.2000	10.2000	10.2000
5	10.2000	10.2000	10.2000	10.2000	10.2000	10.2000	10.2000	10.2000	10.2000	10.2000
6	10.2000	10.2000	10.2000	10.2000	10.2000	10.2000	10.2000	10.2000	10.2000	10.2000
7	10.2000	10.2000	10.2000	10.2000	10.2000	10.2000	10.2000	10.2000	10.2000	10.2000
8	10.2000	10.2000	10.2000	10.2000	10.2000	10.2000	10.2000	10.2000	10.2000	10.2000
9	10.2000	10.2000	10.2000	10.2000	10.2000	10.2000	10.2000	10.2000	10.2000	10.2000
10	10.2000	10.2000	10.2000	10.2000	10.2000	10.2000	10.2000	10.2000	10.2000	10.2000

Bolting joints can be evaluated on a PC



- KBW sensor for nutrunner – Measuring range: up to 6,000 Nm (higher power ranges available on request)



- Test adapter for hydraulic torque wrenches – Measuring range: up to 25,000 Nm (higher power ranges available on request)

Equipment testing



The PH test system, used with the GMV 2, is the ideal combination for testing and setting up hydraulic tools.

- PH test system –
Measuring range: up to 20,000 Nm
(higher power ranges available on request)



Combining the DRT reaction torque sensor with the GMV 2 enables static testing of impact tools, electric torque tools and other equipment of various designs.

- DRT reaction torque sensor –
Measuring range: up to 6,000 Nm
(higher power ranges available on request)



PTB

Our test fittings are checked and accredited by the calibration service at Germany's Federal Physical and Technical Institute



PLARAD



PLARAD

XVR/XVK – usable anywhere!

- Manually operated torque multiplier
- Ideal for use with no external power supply
- Available for use anywhere and at any time

Torque multiplier	Height (mm)	Ø (mm)	Performance range (Nm)	Weight (kg)
XVK 15	172	81	220 - 1,700	2.6
XVR 25	302	81	440 - 2,300	5.2
XVR 35	273	81	510 - 3,600	5.0
XVR 40	238	95	560 - 4,000	6.1
XVR 65	244	114	820 - 6,200	8.4
XVR 70	302	128	980 - 6,800	11.4
XVR 90	300	172	1,780 - 8,600	21.8
XVR D 45	310	128	1,000 - 10,100	16.0

All weights are without reaction arm/subject to amendment.

Compatible torque wrenches



PH 36 Z (60 - 360 Nm),
PH 50 Z (200 - 500 Nm)

XVK
Single-stage torque multiplier

XVR
Multi-stage torque multiplier with reversing safety mechanism ensures extra safety for users

Flexibility thanks to height-adjustable reaction arm



Special solutions



Speedy

Pneumatic speedy nutrunner:
fast operation in low
torque applications



Offset drive

For nutrunner when space
is limited (e.g. plate heat
exchangers)



XB 1

Hydraulic power pack with protective
shields and an extra manometer



Threaded column connection mechanism
for pre-stressed concrete reinforcement



DE
Double nutrunner for production
line cylinder head assembly



PLARAD

Overview

Trolley for hydraulic power packs – for mobility in plants and workshops

Aluminium frame, 2 integrated handles, lockable-quick lock, rollers with solid rubber tyres and roller bearings, brake and caster wheels



Assortment of tubes/hoses and adapters

Plarad hoses with a fourfold safety factor upto 800 bars (bursting pressure 3200 bars)





Lubricants



Various reaction arms



Valve wheel driver for valves

Various sockets and fittings



PLARAD

Customer focus



Consultation and assistance for use of equipment in Russia



Test equipment and product demonstrations available



Product advice from our specialists onsite

Plarad support during the construction of a wind plant in China



TiD-extra
Industrial Technology s.p.a.

Demonstration of equipment by Plarad employees in Italy



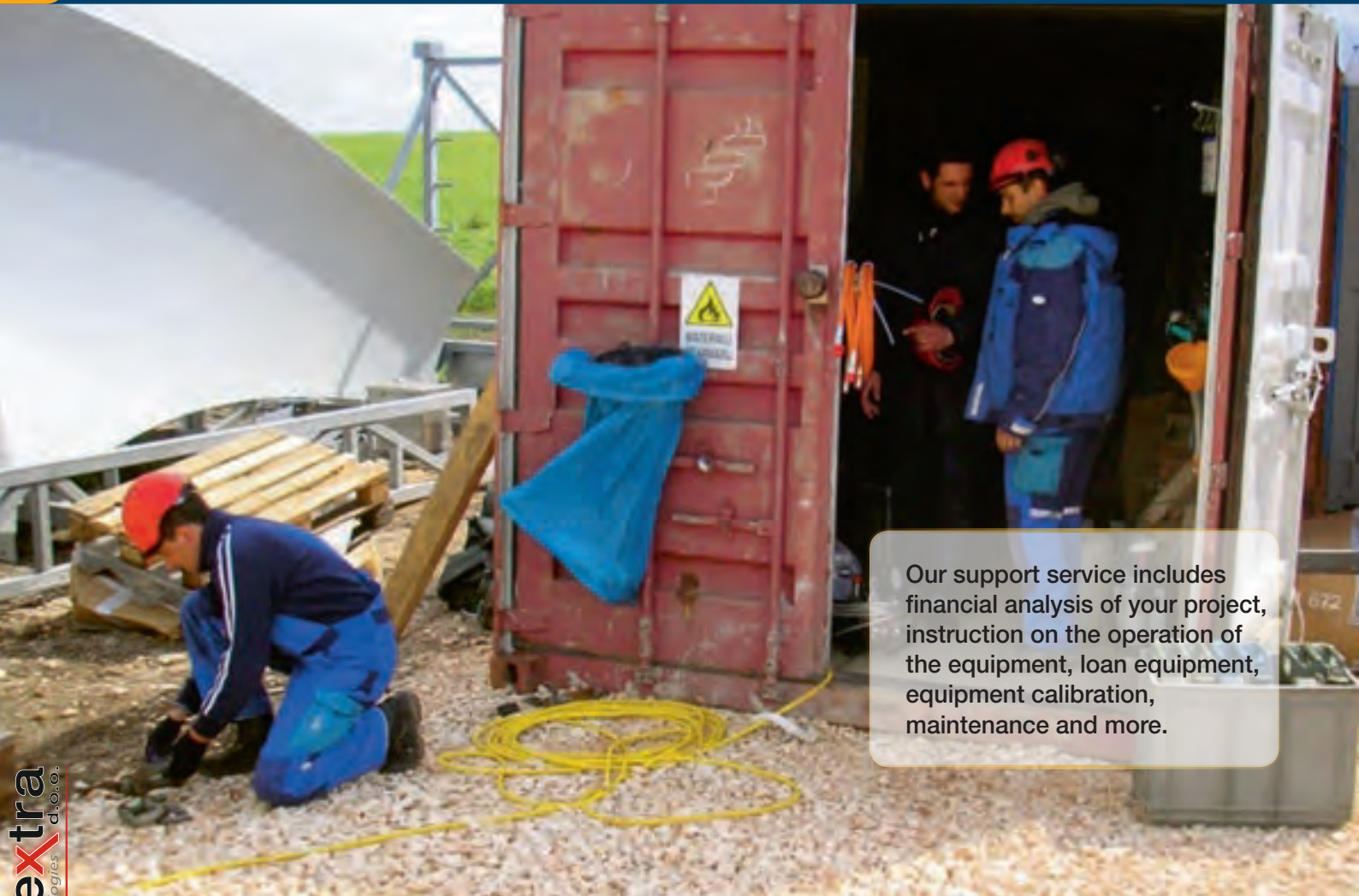

Our support service includes financial analysis of your project, instruction on the operation of the equipment, loan equipment, equipment calibration, maintenance and more.



We check your bolting needs by means of precise measurement of torque while bolts are being tightened.

3D CAD analysis

Give us the data on your bolting joints in whatever format you want:



E.g. Hand-drawn sketch



E.g. Bolting scenario questionnaire



E.g. CAD files



We will use your information to create a 3D model on our own CAD system. This enables us to recommend the optimum tools for your needs. Where appropriate we can customise a bolting system for your individual needs.

You will receive our recommended solution in the form of a printout and a 3D animation (use "Autodesk" dwf viewer).

Our wide range of products enables us to find the most economical solution for you.



PLARAD

We pass on our know-how!

We continually offer advanced training within the organisation to enhance the knowledge of our employees.

We cooperate with PSA Sicherheitstechnik GmbH & Co. KG in operations worldwide, providing detailed support for training and safety instruction (for example, working at height, where this is a risk of falling), both for our own employees and for yours.

Training and seminars for your employees

- **Maintenance and repair of torque tools:**
 - Relevant maintenance
 - Fault diagnosis
 - Repairs
 - Adjustment, calibration and testing
- **User training:**
 - Basic bolt fitting and technology
 - Safety aspects
 - Handling and positioning torque tools
 - Equipment settings
- **Training courses in colleges and academies:**
 - e.g. Basic bolting techniques







TiD-extra
Industrial Technologies d.o.o.

24/7 service

Competent expert help available throughout the world, at any time

- Economic and technical security, thanks to expert consultation anywhere in the world.
- We offer provision for service and maintenance, a reliable supply of spares as well as calibration services.
- One call is enough!
Our 24/7-service team will provide clear quick no-nonsense support.

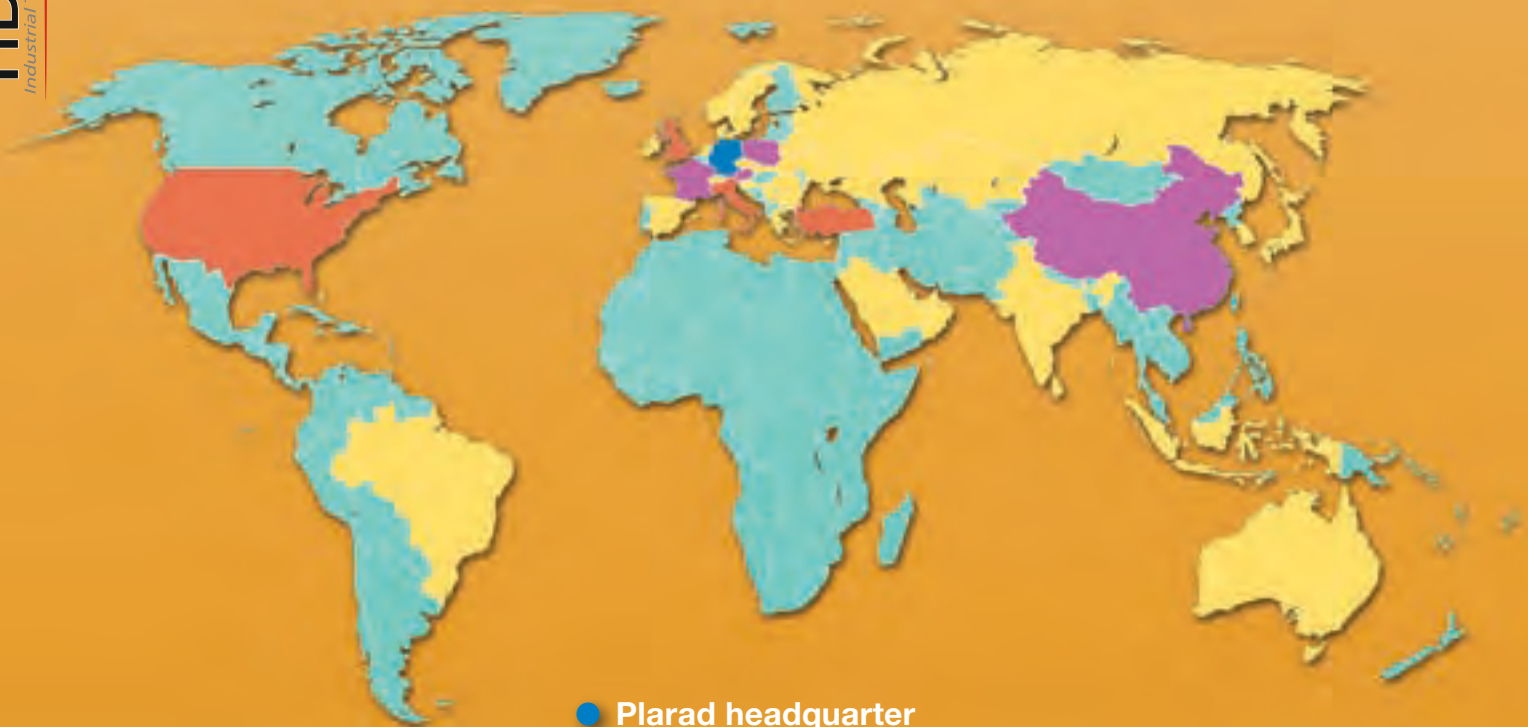

- Plarad headquarter
- Plarad's foreign subsidiaries
- Plarad staff
- Plarad distributors



Maschinenfabrik Wagner GmbH & Co. KG
Birrenbachshöhe · 53804 Much · Germany

Phone national: (02245) 62-0
Fax national: (02245) 62-66
Phone international: +49 (0)2245 62-10
Fax international: +49 (0)2245 62-22

info@plarad.com · www.plarad.com



China

Maschinenfabrik Wagner
Representative Office Beijing

Room 1409 Huashang Building,
No 2 Yan Jing Xi Li Chaoyang District
Beijing 100025

Phone: +86 (0)10 872 160 01-0
Fax: +86 (0)10 872 160 02
E-Mail: info-china@plarad.com

Italy

Plarad Italy Srl

Via della Vecchia Chimica, 10
20070 Cerro al Lambro (MI)

Phone: +39 02 983 29 54
Fax: +39 02 98 11 91 73
E-Mail: italia@plarad.com

Turkey

Plarad - Tork Anahtarları ve Gerdirme
Sistemleri San. Dış. Tic. Ltd. Şti.

Tekstilcent Ticaret Merkezi
A2 Blok, Kat: Giriş D: 22, Oruçreis
Mah. Barbaros Cad.
34220 Esenler · Istanbul

Phone: +90 (0)212 659 77 76
Fax: +90 (0)212 659 77 81
E-Mail: plarad-tork@plarad.com

UK

Plarad UK Ltd.

Parkside Business centre, Unit 4
58/62 Walpole Road,
Bromley, BR2 9SF, London

Phone: +44 (0) 845 643 69 78
Phone: +44 (0) 1294 27 98 43
Fax: +44 (0) 1294 44 30 60
E-Mail: UK@plarad.com

USA

Plarad Bolting
Technologies LLC

1517 W. North Carrier Parkway, Suite 112
Grand Prairie, TX 75050-1251

Phone: +1 (0)469 865 16 49
Fax: +1 (0)469 865 16 53
E-Mail: info@plarad-americas.com