



# Engine Starting Systems



TiD-extra  
d.o.o.

# It All Starts with Ingersoll Rand

For over a half century, Ingersoll Rand has delivered the most reliable air starters for use in the world's most demanding industries and environments. With over 200 models, we have more installations in more applications around the world than any other manufacturer.

- **Leader in Air Starting**  
*broad line of turbine starters, vane starters and barring motors*
- **Best-in-class Performance**  
*horsepower, torque and efficiency*
- **Culture of Innovation**  
*latest technology and superior engineering*
- **Lab Tested, Field Proven**  
*rugged components ensure reliability in harsh conditions*
- **Global Support**  
*worldwide sales, service and engineering*

We invite you to peruse our catalog, learn more about our wide range of products and discover for yourself why the biggest names in the business trust Ingersoll Rand air starters.



Catalog pages with this symbol describe Ingersoll Rand products specified as "original equipment" by global engine manufacturers.

## International Certifications

ISO 9001:2000 — ABS (American Bureau of Shipping) — Lloyd's Register  
Germanischer Lloyd ([www.germanlloyd.org](http://www.germanlloyd.org)) — Korean Register of Shipping

*Certificate information available upon request.*





















































Germanischer Lloyd



# Selection Guide

## Air Starter Industry Selection Guide

ENGINE STARTER SERIES						
	Locomotive	Marine	Off-Highway	Oil & Gas	Power Generation	Transportation
<b>TURBINE STARTERS</b>						
150T "F" Series						
ST400						
ST500						
ST600						
ST700/ST900						
ST1000/ST1000M						
<b>VANE STARTERS</b>						
SS100						
SS350						
150BM						
SS800						
<b>GAS TURBINE STARTERS</b>						
TS700/TS900/TS1400						
<b>BARRING MOTORS</b>						
B006						
T480						

# Contents

Description	Page #
<b>Air Starter Industry Selection Guide</b>	<b>3</b>
<b>Turbine Starters</b>	<b>5</b>
<b>Turbine Starter Selection Guide</b>	<b>6</b>
<b>150™ “F” Series</b>	<b>7-9</b>
<i>Features – Benefits</i>	7
<i>Dimensions – Performance Information – Model Coding</i>	8
<i>Parts and Accessories – Replacement Kits</i>	9
<b>ST400 Series</b>	<b>10-11</b>
<i>Features/Benefits – Model Coding – Dimensions</i>	10
<i>Performance Information – Parts and Accessories – Replacement Kits</i>	11
<b>ST500 Series</b>	<b>12-14</b>
<i>Features/Benefits</i>	12
<i>Dimensions – Performance Information – Model Coding</i>	13
<i>Parts and Accessories – Replacement Kits</i>	14
<b>ST600 Series</b>	<b>15-16</b>
<i>Features/Benefits – Dimensions</i>	15
<i>Performance Information – Model Coding – Parts and Accessories – Replacement Kits</i>	16
<b>ST700/900 Series</b>	<b>17-20</b>
<i>Features/Benefits – Model Coding</i>	17
<i>Dimensions – Performance Information</i>	18
<i>Parts and Accessories – Replacement Kits</i>	19
<i>Replacement Kits (cont.)</i>	20
<b>ST1000/1000M Series</b>	<b>21-24</b>
<i>Features/Benefits</i>	21
<i>Dimensions</i>	22
<i>Performance Information</i>	23
<i>Replacement Kits – Parts and Accessories</i>	24
<b>Vane Starters</b>	<b>25</b>
<b>Vane Starter Selection Guide</b>	<b>26</b>
<b>SS100 Series</b>	<b>27-29</b>
<i>Features/Benefits</i>	27
<i>Dimensions – Orientations – Performance Information</i>	28
<i>Model Coding – Parts and Accessories – Replacement Kits</i>	29

Description	Page #
<b>150BM Series</b>	<b>30-32</b>
<i>Features/Benefits – Model Coding</i>	30
<i>Dimensions – Performance Information</i>	31
<i>Parts and Accessories – Replacement Kits</i>	32
<b>SS350 Series</b>	<b>33-35</b>
<i>Features/Benefits – Model Coding</i>	33
<i>Dimensions – Performance Information</i>	34
<i>Replacement Kits – Parts and Accessories</i>	35
<b>SS800 Series</b>	<b>36-38</b>
<i>Features/Benefits – Model Coding</i>	36
<i>Dimensions – Performance Information</i>	37
<i>Replacement Kits – Parts and Accessories</i>	38
<b>TS700/TS900/TS1400 Series</b>	<b>39-44</b>
<i>Features/Benefits – Dimensions</i>	39
<i>Dimensions (cont.)</i>	40-41
<i>Performance Information</i>	42
<i>Engine Selection Guide – Output Spline Data – Model Coding</i>	43
<i>Parts and Accessories – Replacement Kits</i>	44
<b>Barring Motor Series</b>	<b>45-46</b>
<i>Features/Benefits</i>	45
<i>Performance Information – Parts and Accessories</i>	46
<b>Accessories</b>	<b>47-57</b>
<i>Accessories Index</i>	47
<i>Relay Valves</i>	48-49
<i>Solenoid Control Valves</i>	50-51
<i>Push Button</i>	52
<i>Air Strainers</i>	53
<i>Mufflers</i>	54
<i>In-Line Lubricators</i>	55
<i>Regulators</i>	56
<b>Installation Configurations</b>	<b>57-63</b>

# High-Performance from Start to Finish

## Turbine Starters



**Patented  
slip-fit, modular  
motor design**

makes servicing  
simple and  
convenient.



From the remotest mines to the open seas, Ingersoll Rand turbine air starters withstand the toughest environmental and working conditions. Robust features and flexibility combine to deliver reliable, heavy-duty starting power for a wide range of industrial, oil and gas, marine, power generation, rail and mining applications.

Unlike cantilever designs, our fully-supported, high-speed rotors extend bearing life by minimizing deflection and ensuring concentric operation. Add in our lightweight, lube-free and field-serviceable motor design, and it's no wonder Ingersoll Rand turbine air starters are specified by premier engine OEMs across the globe.

- Lube-free turbine motor
- Easy field serviceability
- Robust gearing handles long crank cycles
- Fully-supported rotor for longer bearing life
- Sealed, oil-lubricated planetary sets (preferred worldwide for high-performance gear trains)
- Solid aluminum rotor design tames harsh, contaminated environments\*
- Modular motor design shares components with vane starters to reduce parts inventory
- Proven Ingersoll Rand front-end engagement system for greater reliability
- Class-leading power, durability and efficiency

\* ST1000 Series



# Turbine Starters

## Turbine Starter Selection Guide (Lubrication Free)

For Diesel Engine Displacement (liters)	Catalog Pages	Series	Gear Ratio	Extended Starting Capability (>10 sec.)	Max Power (hp)	Max Pressure (psi (bar))	Air Consumption at Max HP scfm (L/s)	Engagement Type**	Inlet Size (NPT)	Exhaust Size (NPT)	Gas Sealed
8 to 27	7-9	150TMG	F	Yes	28	150 (10.3)	710 (335)	Inertia	1 1/4"	2"	Yes
8 to 27	7-9	150TMP	F	Yes	28	150 (10.3)	710 (335)	Pre-Engaged	1 1/4"	2"	Yes
8 to 70	7-9	150TLP	F	Yes	28	90 (6.2)	780 (368)	Pre-Engaged	1 1/4"	2"	Yes
5 to 60	10-11	ST400	C	Yes	25	150 (10.3)	750 (354)	Pre-Engaged	1"	NA	No
5 to 60	10-11	ST455	C	Yes	23	120 (8.3)	780 (368)	Pre-Engaged	1"	NA	No
5 to 60	12-14	ST499	C	Yes	26	90 (6.2)	765 (361)	Pre-Engaged	1"	NA	No
5 to 100	12-14	ST599	F	Yes	44	150 (10.3)	1240 (585)	Pre-Engaged	1 1/4"	2"	Yes
5 to 100	15-16	ST544	F	Yes	28	150 (10.3)	710 (335)	Pre-Engaged	1 1/4"	2"	Yes
16 to 80	15-16	ST650	B	Yes	66	150 (10.3)	1450 (684)	Pre-Engaged	1 1/4"	5" V-Band Flange	No
16 to 80	15-16	ST699	B	Yes	67	90 (6.2)	1700 (802)	Pre-Engaged	1 1/2"	5" V-Band Flange	No
16 to 130	17-20	ST750/ ST950	B	No/Yes	55	150 (10.3)	1300 (614)	Inertia/ Pre-Engaged	1 1/2"	4" *	Yes
16 to 130	17-20	ST750/ ST999	B	No/Yes	66	90 (6.2)	1700 (802)	Inertia/ Pre-Engaged	1 1/2"	4" *	Yes
80 to 200	17-20	ST750/ ST950	C	No/Yes	55	150 (10.3)	1300 (614)	Pre-Engaged	1 1/2"	4" *	Yes
80 to 200	17-20	ST750/ ST999	C	No/Yes	66	90 (6.2)	1700 (802)	Pre-Engaged	1 1/2"	4" *	Yes
16 to 130	21-24	ST1060	B	Yes	70	150 (10.3)	1290 (609)	Inertia/ Pre-Engaged	1 1/2"	4" *	Yes
16 to 130	21-24	ST1099	B	Yes	68	90 (6.2)	1240 (585)	Inertia/ Pre-Engaged	1 1/2"	4" *	Yes
80 to 200	21-24	ST1060	C	Yes	70	150 (10.3)	1290 (609)	Pre-Engaged	1 1/2"	4" *	Yes
80 to 200	21-24	ST1099	C	Yes	68	90 (6.2)	1240 (585)	Pre-Engaged	1 1/2"	4" *	Yes
160 to 320	21-24	ST1060	D	Yes	70	150 (10.3)	1290 (609)	Pre-Engaged	1 1/2"	4" *	Yes
160 to 320	21-24	ST1099	D	Yes	68	90 (6.2)	1240 (585)	Pre-Engaged	1 1/2"	4" *	Yes
Gas Turbine Engines	39-44	TS700/ TS900	D	Yes	130	225 (15.5)	2200 (1038)	Permanently Engaged	1 1/2"	4" *	Yes

\* Or exhaust through a welded flanged 3 1/2" schedule 40 pipe.

These figures are only a guide. For difficult-to-start engines or for operation under adverse conditions, use the next more powerful starter. For 2-stroke diesel engines, these figures may be multiplied by 1.5. Ex: a 150TMG could be used in a 41 liter 2-stroke diesel engine. For carbureted (gas) engines, these figures may be doubled. Ex: a 150BMP could be used on a 54 liter gasoline engine. Note 1 liter = 61.02 in<sup>3</sup>.

\*\* There are two basic types of air starters: pre-engaged and inertia. With pre-engaged starters, the drive pinion is completely engaged with the engine ring gear before the starter begins to crank the engine. With an inertia starter, the rotating drive pinion engages the engine ring gear simultaneously with the initial cranking of the engine.

# Turbine Starters

## 150™ “F” Series



**For engine displacement of:**  
Diesel—500 to 4300 CID (8 to 70 liters)  
Carbureted—1000 to 8600 CID (16 to 140 liters)

### Features/Benefits

- Efficient 36 hp turbine motor uses no external lubrication
- Same inlet and outlet locations as the 150BM Series starters for easy change-out
- Uses the proven front end of the 150BM starter
- Sealed, oil-lubricated planetary gears provide maintenance-free operation

### Versatile

- Sealed for use in gas and air applications
- Inertia and pre-engaged models
- Left- and right-hand rotation
- 4 inlet, 4 exhaust, and 16 drive housing orientations
- 30-150 psi (2.1-10.3 bars) operation

### Industry Applications



# Turbine Starters

## Dimensions

Weight: 35 lbs (15.9 kg)

**Note:** All dimensions shown are for reference only. Specifications subject to change without notice.

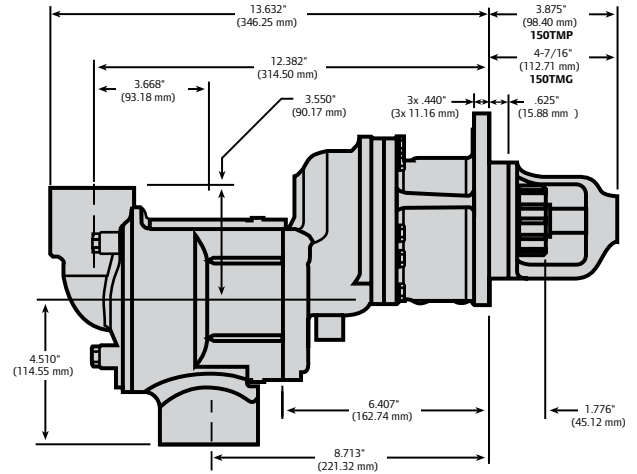
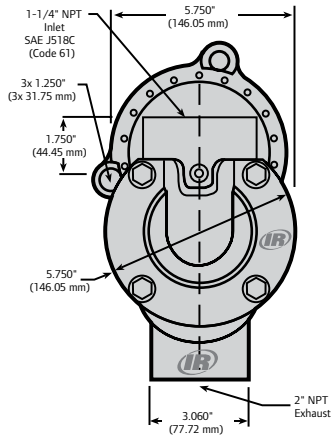

## Performance Information

Pressure psi (bar)	Breakaway Torque ft-lb (Nm)	Speed @ Max HP rpm	Max Power hp (kW)	Flow @ Max HP scfm (L/s)
<b>150TMPF/150TMGF – 44% ARC</b>				
60 (4.1)	74 (100)	1296	9 (7)	310 (146)
90 (6.2)	113 (153)	1480	16 (12)	430 (203)
120 (8.3)	147 (200)	1580	22 (17)	570 (269)
150 (10.3)	182 (247)	1620	28 (21)	710 (335)
<b>150TLPF – 99% ARC</b>				
30 (2.1)	72 (98)	1185	8 (6)	340 (160)
60 (4.1)	132 (179)	1500	19 (14)	580 (274)
90 (6.2)	206 (280)	1530	30 (23)	780 (368)
120 (8.3)	247 (336)	1540	36 (46)	1000 (475)

**TiD-extra**  
 Industrial Technologies d.o.o.

## Model Coding

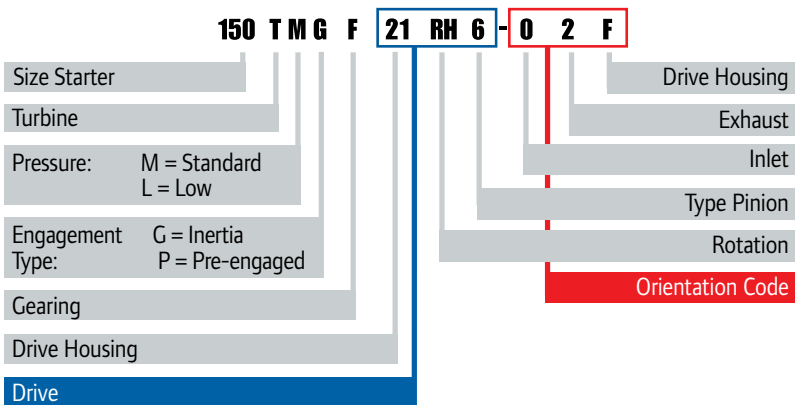

## Simple Crossover:

Current 150BM models are superseded to the 150T™ “F” models by replacing the “B” with a “T” and the “E” with an “F”.

*Example:*

150BMPE88R54 = 150TMPF88R54

For low pressure applications (less than 90 psi or 6.2 bar) replace the “M” with an “L”.











*Example:*

150TMPE88R54 = 150LTPF88R54



# Turbine Starters

## Parts and Accessories

Part #	Description
 ST500-674 or 150T-312	2" Muffler
 150BMP-1051B	1/4" 12 V Solenoid Valve
 150BMP-2451B	1/4" 24 V Solenoid Valve
 SMB-G618	Gas Rated Push Button Valve
 SMB-618	Push Button Valve
 SRV125F	1-1/4" Relay/Solenoid Valve
 SRV125T	1-1/4" Relay Valve for Transit Aftermarket
 SRV125	1-1/4" Relay Valve for Stationary Air
 SRV150SS	1-1/2" Gas Rated Relay Valve
 150BMP-1058	Gladhand

Part #	Description
 150BMP-1064	1/8", 150 psi Pressure Gauge
 *ST900-267H/150	1-1/2" Strainer Housing
 *ST900-266/150-HP	1-1/2" Strainer (50 microns)
 ST500-A735	2" Road Splash Deflector
 150BMP-1056	1/2" Check Valve
 150BMP-1067	1/2" Drain Valve
 ST500-K166	SAE J518 Split Flange

\*For complete filter (strainer + housing), please order ref ST900-267/150-HP

## Genuine Ingersoll Rand Replacement Kits

Tune Up Kit Part Number	Description
150TMP-TK1	150T Pre-engaged Starter Tune Up Kit
150TMG-TK1	150T Inertia Starter Tune Up Kit



150TMP-TK1 Parts



150TMG-TK1 Parts

## Motor Modules

Motor Module Part Number	Description
150TMFR-100	RH Half Arc Motor Module
150TMFL-100	LH Half Arc Motor Module
150TLFR-100	RH Half Arc Motor Module
150TLFL-100	LH Half Arc Motor Module

**Note:** The motor module can be used to convert an E ratio to an F ratio 150T starter and includes the motor and the gearing section.

# Turbine Starters

## ST400 Series



**For engine displacement of:**  
Diesel-300 to 3600 CID (5 to 60 liters)



### Industry Applications

MARINE



POWER GENERATION



### Features/Benefits

- Efficient 26 hp turbine motor uses no external lubrication
- One-hose hookup simplifies required piping
- In-line design weighs only 23 lbs (10.4 kg)
- Sealed oil-bath lubrication for gears and bearings provides maintenance free operation

### Versatile

- Removable mounting flange can be rotated 360 degrees for greater mounting flexibility
- Compact, lightweight design makes installation easy
- Overhung pinion design fits most worldwide manufacturers' engines
- 30-150 psi (2.1-10.3 bars) operation

### Model Coding

**ST400 I C 03 R 31**

ST400 - 44% ARC  
Max. 10.3 bar

ST455 - 55% ARC  
Max. 8.3 bar

ST499 - 99% ARC  
Max. 6.2 bar

I = 1" NPT  
No letter = SAE Split Flange

C = Gear Ratio

Pinion Code

R = Right Hand  
L = Left hand

01 = SAE 1 Flange  
03 = SAE 3 Flange

### Dimensions

Weight: 38 lbs (17.2 kg)

**Note:** All dimensions shown are for reference only. Specifications subject to change without notice.

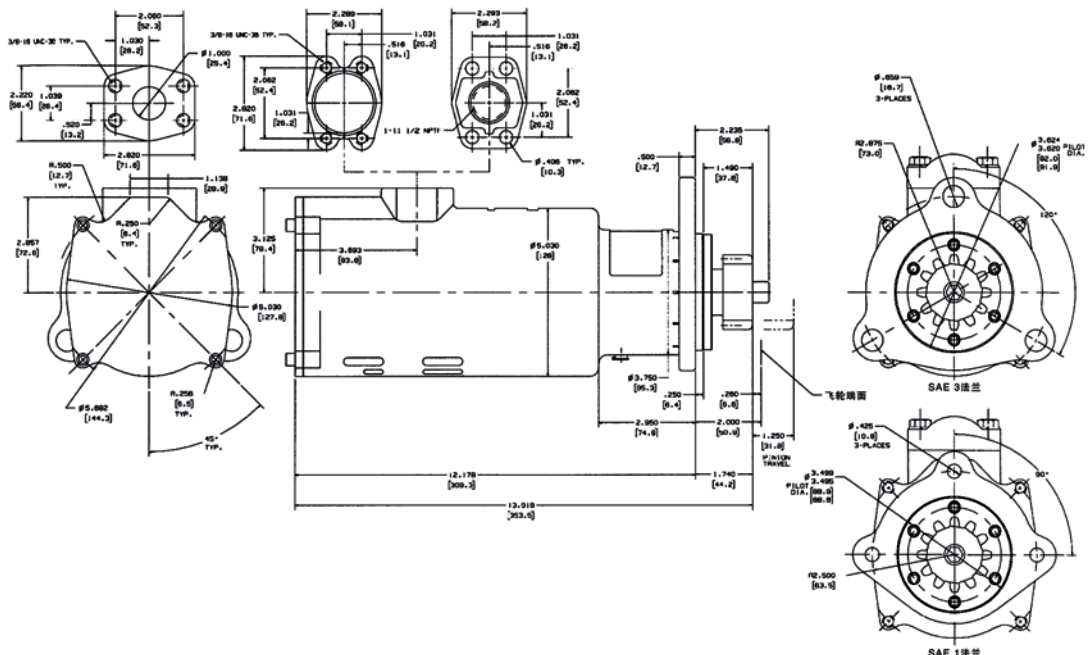

# Turbine Starters

## Performance Information



Pressure psi (bar)	Breakaway Torque ft-lb (Nm)	Speed @ Max HP rpm	Max Power hp (kW)	Flow @ Max HP scfm (L/s)
<b>ST400 – 44% ARC</b>				
90 (6.2)	90 (122)	1500	14 (10)	430 (203)
120 (8.3)	120 (163)	1650	19 (14)	600 (284)
150 (10.3)	150 (203)	1650	25 (19)	750 (354)
<b>ST455 – 55% ARC</b>				
60 (4.1)	80 (109)	1400	10 (7)	23 (17)
90 (6.2)	135 (183)	1450	18 (13)	650 (307)
120 (8.3)	185 (251)	1500	23 (17)	780 (368)
<b>ST499 – 99% ARC</b>				
30 (2.1)	50 (68)	1550	7 (5)	320 (251)
60 (4.1)	115 (156)	1600	14 (10)	550 (260)
90 (6.2)	185 (251)	1650	26 (19)	765 (361)

## Parts and Accessories

Part #	Description
 150BMP-1051B	1/4" 12 V Solenoid Valve
 150BMP-2451B	1/4" 24 V Solenoid Valve
 SMB-618	Push Button Valve
 SRV125F	1-1/4" Relay/Solenoid Valve
 SRV125T	1-1/4" Relay Valve for Transit Aftermarket
 SRV125	1-1/4" Relay Valve for Stationary Air
 SRV150	1-1/2" Relay Valve
 *ST900-267H/150	1-1/2" Strainer Housing
 *ST900-266/150-HP	1-1/2" Strainer (50 microns)
 ST400-A339M	Manual Control Valve

\*For complete filter (strainer + housing), please order ref ST900-267/150-HP

## Parts and Accessories

Part #	Description
 ST400-C339	Relay Valve with top-mounted Solenoid
 ST400-K17	1" NPT Flange Kit
 ST400-16	SAE J518 Split Flange

## Genuine Ingersoll Rand Replacement Kits

Tune Up Kit Part Number	Description
<b>Liner Assembly</b>	
ST400-A41R	Standard Arc Right Hand
ST400-A41L	Standard Arc Left Hand
ST455-A41R	55% Arc Right Hand
ST455-A41L	55% Arc Left Hand
ST499-A41R	Full Arc Right Hand
ST499-A41L	Full Arc Left Hand

# Turbine Starters

## ST500 Series



### For engine displacement of:

Diesel—500 to 6000 (8 to 100 liters)

Carbureted—1000 to 12,000 CID (16 to 200 liters)

### Features/Benefits

- Powerful 44 hp turbine motor uses no external lubrication
- Steel insert at inlet ensures a solid connection
- Smooth pre-engagement piston minimizes ring gear wear
- Sealed, oil-lubricated planetary gears provide maintenance-free operation

### Versatile

- Sealed for use in gas and air applications
- For use with air or natural gas
- 4 inlet, 4 exhaust, and 16 drive housing orientations
- Left- or right-hand rotation
- Optional pinions and flanges to fit most engines
- 30-150 psi (2.1-10.3 bars) operation

### Industry Applications

MARINE



OIL & GAS



OFF-HIGHWAY



POWER GENERATION



# Turbine Starters

## Dimensions

Weight: 38 lbs (17.2 kg)

**Note:** All dimensions shown are for reference only. Specifications subject to change without notice.

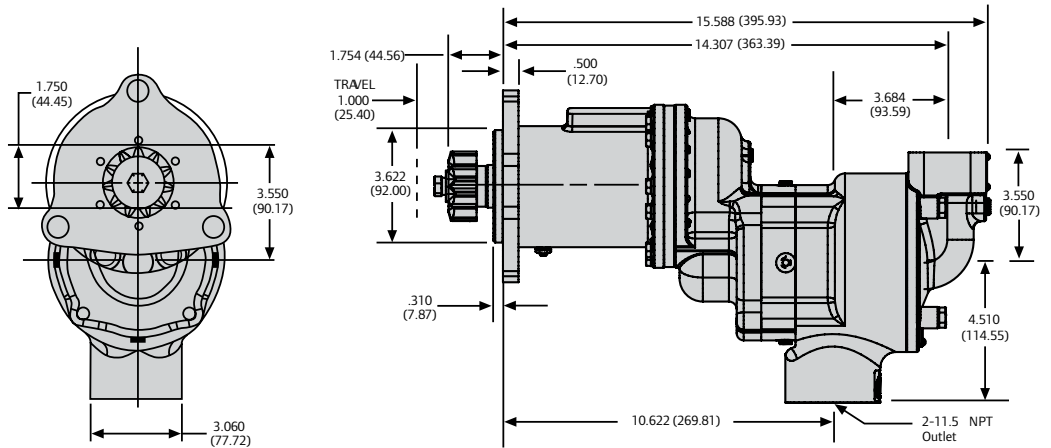

## Performance Information

Pressure psi (bar)	Breakaway Torque ft-lb (Nm)	Speed @ Max HP rpm	Max Power hp (kW)	Flow @ Max HP scfm (L/s)
<b>ST544</b>				
60 (4.1)	74 (100)	1296	9 (7)	310 (146)
90 (6.2)	113 (153)	1480	16 (12)	430 (203)
120 (8.3)	147 (200)	1580	22 (17)	600 (284)
150 (10.3)	182 (247)	1620	28 (21)	750 (354)
<b>ST599</b>				
30 (2.1)	72 (98)	1185	8 (6)	340 (160)
60 (4.1)	132 (179)	1500	19 (14)	580 (274)
90 (6.2)	206 (280)	1530	30 (23)	780 (368)
120 (8.3)	247 (336)	1540	36 (46)	1000 (475)
150 (10.3)	295 (400)	1560	44 (58)	1240 (585)





## Model Coding





**ST544 F 03 R 25 - 0 2 F J**



# Turbine Starters

## Parts and Accessories

Part #	Description
 150BMP-1051B	1/4" 12 V Solenoid Valve
 SMB-G618	Gas Rated Push Button Valve
 SMB-618	Push Button Valve
 SRV125T	1-1/4" Relay Valve for Transit Aftermarket
 SRV125	1-1/4" Relay Valve for Stationary Air
 150BMP-1064	1/8", 150 psi Pressure Gauge
 ST500-A735	2" Road Splash Deflector

Part #	Description
 ST500-K166	SAE J518 Split Flange
 150BMP-1056	1/2" Check Valve
 150T-312	2" Muffler
 SMB-441	Liquid Sealant
 *ST900-267H/150	1-1/2" Strainer Housing
 *ST900-266/150-HP	1-1/2" Strainer (50 microns)

\*For complete filter (strainer + housing), please order ref ST900-267/150-HP

TiD-extra  
Industrial Technologies d.o.o.

## Genuine Ingersoll Rand Replacement Kits

Tune Up Kit Part Number	Description
ST500-TK1	ST500 Starter Tune Up Kit
ST500-SK1	ST500 Seal Kit

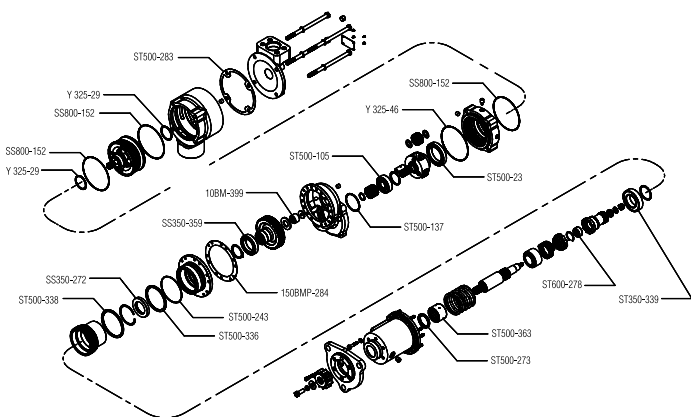

Exploded View of ST500-TK1 Part Location

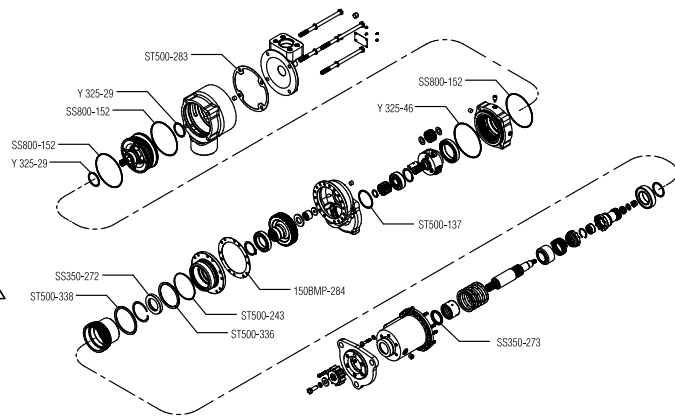

Exploded View of ST500-SK1 Part Location

# Turbine Starters

## ST600 Series



**For engine displacement of:**  
 Diesel—1000 to 5000 CID (16 to 80 liters)  
 Carbureted—2000 to 10,000CID (32 to 160 liters)

### Features/Benefits

- Powerful 67 hp turbine motor uses no external lubrication
- Extended pilot for easier installation
- Offset pre-engaged ports for greater fitting positioning
- Smooth pre-engagement for limited ring gear wear
- 39 lb (17.7 kg) weight makes it the lightest starter in its class

### Versatile

- In-line design and lightweight make installation easy
- Left or right-hand rotation
- 8 orientation options
- 30-150 psi (2.1-10.3 bars) operation
- For use with air only

### Industry Applications

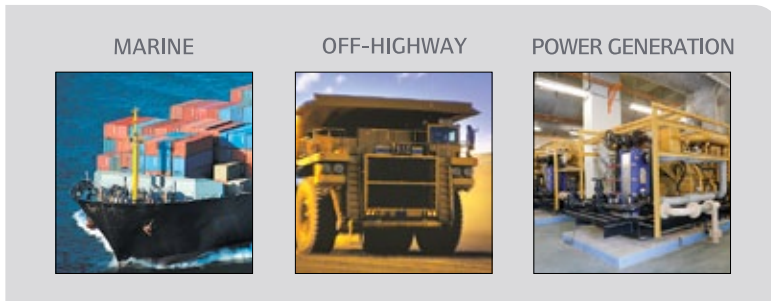

**TiD-extra**  
 Industrial Technologies d.o.o.

### Dimensions

Weight: 39 lbs (17.7 kg)

**Note:** All dimensions shown are for reference only. Specifications subject to change without notice.

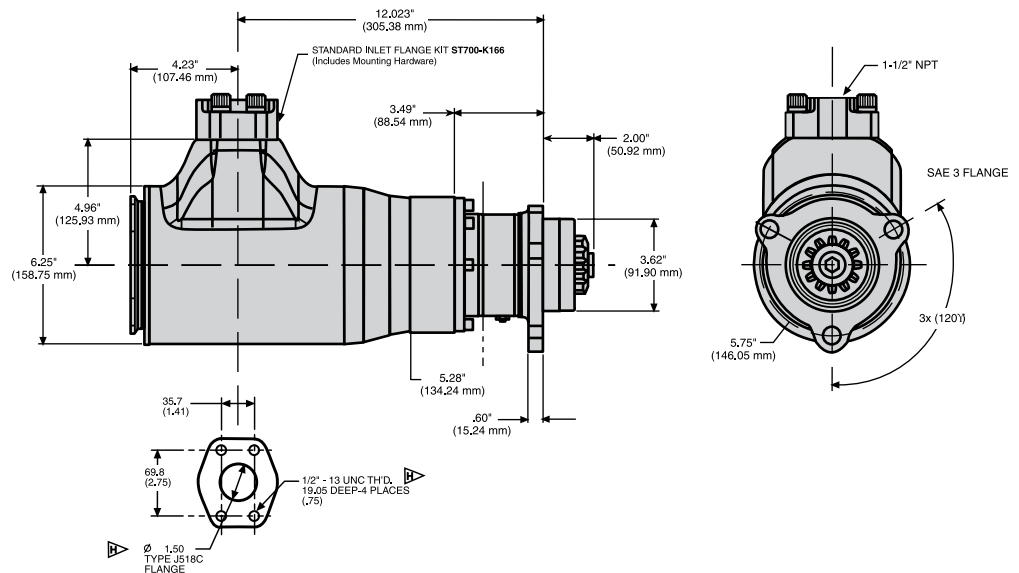

### Inlet Flange Kit (ST700-K166)

Weight: 4.5 lbs (2.0 kg)

# Turbine Starters

## Performance Information

Pressure psi (bar)	Breakaway Torque ft-lb (Nm)	Speed @ Max HP rpm	Max Power hp (kW)	Flow @ Max HP scfm (L/s)
<b>ST650B</b>				
90 (6.2)	155 (210)	2300	34 (25)	850 (401)
120 (8.3)	225 (305)	2350	50 (37)	1150 (543)
150 (10.3)	260 (352)	2600	65 (49)	1450 (684)
<b>ST699B</b>				
30 (2.1)	110 (149)	1950	20 (15)	600 (283)
60 (4.1)	195 (264)	2200	41 (31)	1150 (543)
90 (6.2)	290 (393)	2400	67 (50)	1700 (802)

**Note:** Overtorque safety clutch set between 330 to 440 ft-lb (447 to 596 Nm)

## Parts and Accessories

	Part #	Description
	150BMP-1051B	1/4" 12 V Solenoid Valve
	150BMP-2451B	1/4" 24 V Solenoid Valve
	SMB-G618	Gas Rated Push Button Valve
	SMB-618	Push Button Valve
	SRV150	1-1/2" Relay Valve
	150BMP-1058	Gladhand
	150BMP-1064	1/8", 150 psi Pressure Gauge
	ST900-267H/150	1-1/2" Strainer Housing
	ST900-266/150-HP	1-1/2" Strainer (50 microns)
	150BMP-1056	1/2" Check Valve
	150BMP-1067	1/2" Drain Valve

## Model Coding

**ST6 50 B P 03 R 31**

Turbine Starter Series	Pinion
Percent Arc	Rotation
Gear Ratio	SAE Flange
	Pre-engaged

## Genuine Ingersoll Rand Replacement Kits

Tune Up Kit Part Number	Description
ST600-TK1	ST600 Starter Tune Up Kit
ST600-SK1	ST600 Starter Seal Kit

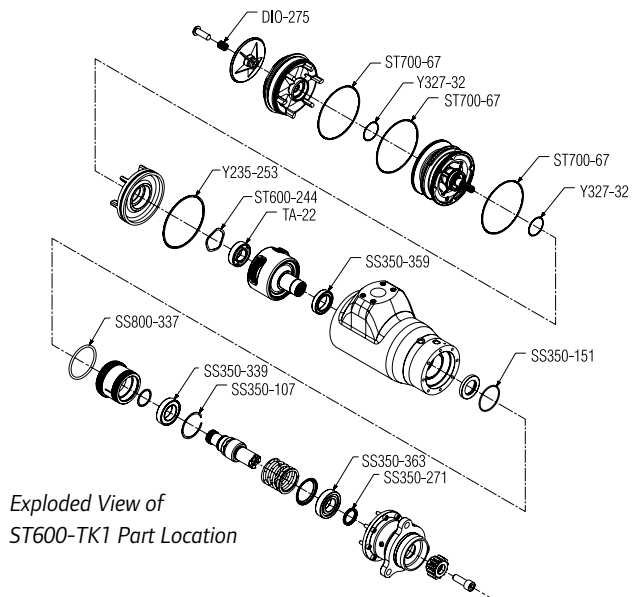



# Turbine Starters

## ST700/900 Series

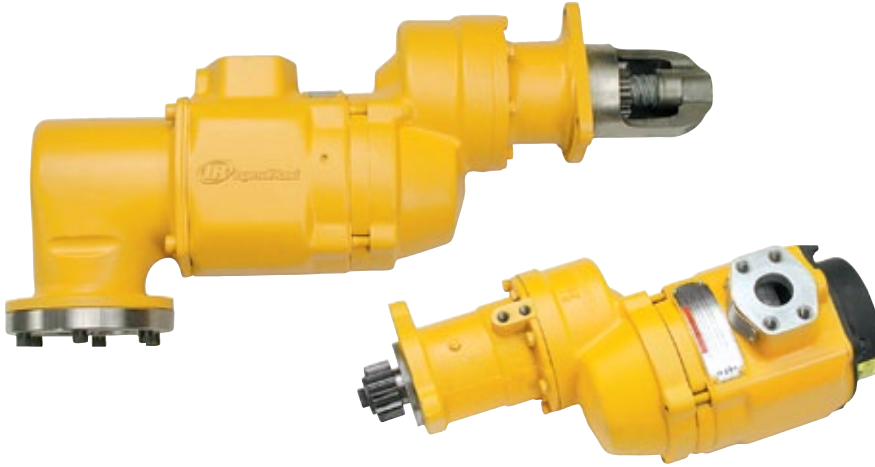

**For engine displacement of:**  
 Diesel—1000 to 20,000 CID  
 (16 to 320 liters)  
 Carbureted—2000 to 40,000 CID  
 (32 to 660 liters)

### Features/Benefits

- Powerful 66 hp turbine motor uses no external lubrication
- Robust gearing handles extended crank cycles
- B and C gearing options provide a broad range of starting torques
- Sealed, oil-lubricated planetary gears provide maintenance-free operation

### Versatile

- Sealed for use in gas and air applications
- Left- or right-hand rotation
- 4 inlet, 4 exhaust, and 16 housing orientations
- 30-150 psi (2.1-10.3 bars) operation
- Inertia and pre-engaged drives

### Industry Applications

MARINE



OIL & GAS



OFF-HIGHWAY



LOCOMOTIVE

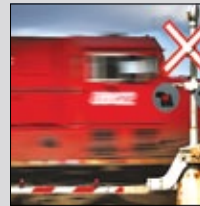

POWER GENERATION



### Model Coding for ST700

**ST7 50 G B D P 03 R 31 - 2 P**

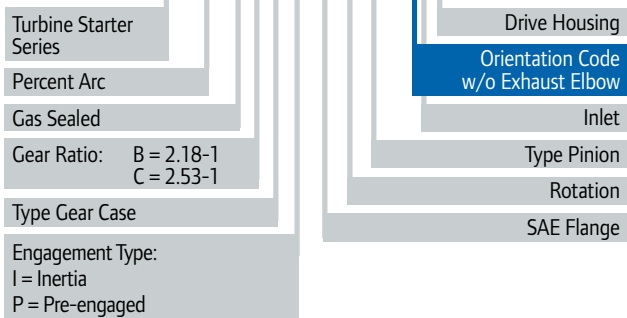

### Model Coding for ST900

**ST9 50 B P 03 R 31 - 0 2 G**

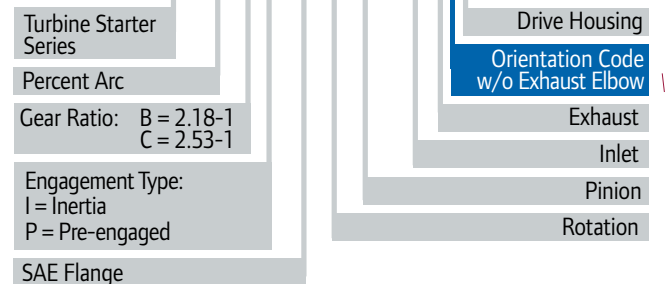

For non-standard positions order orientation “-POS”

# Turbine Starters

## Dimensions

### ST750/ST799GBI & ST950/ST999BI Inertia

Weight:

ST750/ST799GBI 62 lbs (28.1 kg)

ST950/ST999BI 62 lbs (28.1 kg)

**Note:** All dimensions shown are for reference only. Specifications subject to change without notice.

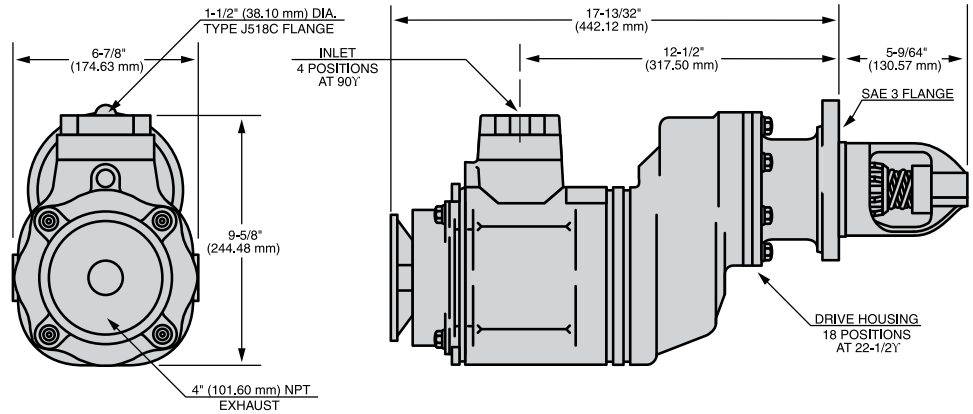

### ST750/ST799 & ST950/ST999 B & C Ratio Pre-engaged

Weight:

ST750/ST799GBPD 63 lbs (28.6 kg)

ST950/ST999BP 63 lbs (28.6 kg)

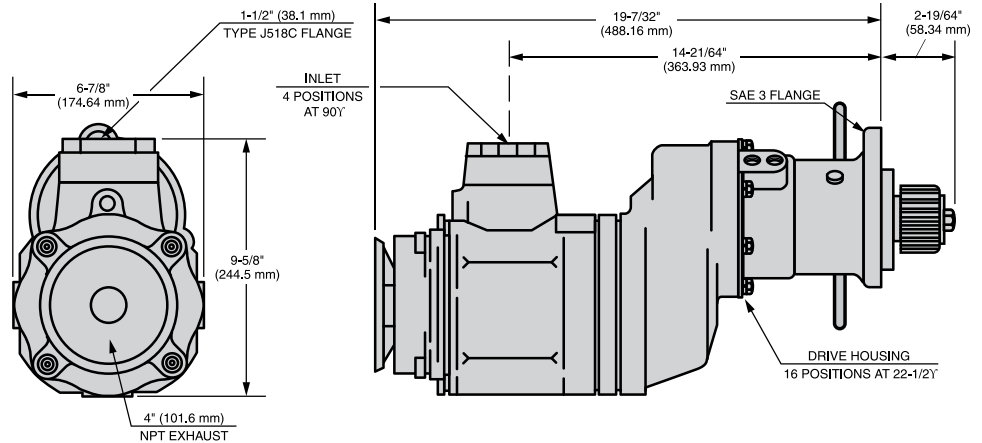





## Performance Information

Pressure psi (bar)	Breakaway Torque ft-lb (Nm)	Speed @ Max HP rpm	Max Power hp (kW)	Flow @ Max HP scfm (L/s)
<b>ST750/ST950 B Ratio (Inertia &amp; Pre-engaged)</b>				
90 (6.2)	160 (217)	1950	30 (22)	850 (401)
120 (8.3)	225 (305)	2100	45 (34)	1100 (519)
150 (10.3)	250 (339)	2350	55 (41)	1300 (614)
<b>ST799/ST999 B (Inertia &amp; Pre-engaged)</b>				
30 (2.1)	110 (149)	1750	18 (13)	700 (330)
60 (4.1)	195 (264)	1950	36 (27)	1200 (566)
90 (6.2)	310 (420)	2250	66 (49)	1700 (802)
<b>ST750/ST950 C Ratio (Pre-engaged)</b>				
90 (6.2)	190 (257)	1675	30 (22)	850 (401)
120 (8.3)	260 (352)	1800	45 (34)	1100 (519)
150 (10.3)	285 (386)	2000	55 (41)	1300 (614)
<b>ST799/ST999 C Ratio (Pre-engaged)</b>				
30 (2.1)	130 (175)	1500	18 (13)	700 (330)
60 (4.1)	225 (305)	1630	36 (27)	1200 (566)
90 (6.2)	360 (485)	1935	66 (49)	1700 (802)

# Turbine Starters

## Parts and Accessories

Part #	Description
 150BMP-1051B	1/4" 12 V Solenoid Valve
150BMP-2451B	1/4" 24 V Solenoid Valve
 SMB-G618	Gas Rated Push Button Valve
 SMB-618	Push Button Valve
 SRV150	1-1/2" Relay Valve for Air
SRV150SS	1-1/2" Gas Rated Relay Valve
 150BMP-1058	Gladhand

Part #	Description
 150BMP-1064	1/8", 150 psi Pressure Gauge
 *ST900-267H/150	1-1/2" Strainer Housing
ST900-267H/200	2" Strainer Housing
 *ST900-266/150-HP	1-1/2" Strainer (50 microns)
ST900-266/200-HP	2" Strainer Element (50 microns)
 150BMP-1056	1/2" Check Valve
 150BMP-1067	1/2" Drain Valve

\*For complete filter (strainer + housing), please order ref ST900-267/150-HP

## Genuine Ingersoll Rand Replacement Kits

Tune Up Kit Part Number	Description
ST700-TK1	ST700 Starter Tune Up Kit
ST700I-TK6	ST700 Inertia Front End Tune Up Kit
ST700P-TK7	ST700 Pre-Engaged Front End Tune Up Kit
ST700D-TK8	ST700 and ST900 D Ratio Kit (4 O-Rings, 1 Retainer Ring)
ST750R-TK2	ST700-TK1 and ST750R-A53 Motor Assembly for RH ST750 Starters

Tune Up Kit Part Number	Description
ST750L-TK3	ST700-TK1 and ST750L-A53 motor assembly for LH ST750 starters
ST799R-TK4	ST700-TK1 and ST799R-A53 motor assembly for RH ST799 starters
ST799L-TK5	ST700-TK1 and ST799L-A53 motor assembly for LH ST799 starters
ST900-GK1	ST900 Gear Kit
ST900-SK1	ST900 Seal Kit



ST700-TK1 Parts



ST700P-TK7 Parts



# Turbine Starters

## ST1000/ST1000M Series

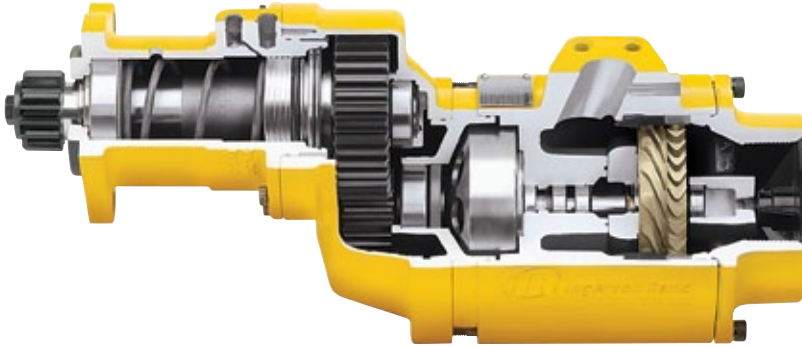

**For engine displacement of:**  
Diesel—1000 to 20,000 CID  
(16 to 320 liters)  
Carbureted—2000 to 40,000 CID  
(32 to 660 liters)

### Features/Benefits

- Powerful 70 hp turbine motor uses no external lubrication and offers best in class efficiency
- Patented, solid aluminum motor design enables reliable operation in harsh, contaminated environments
- Robust gearing handles extended crank cycles
- Patented, fully-supported high-speed rotor extends bearing life by minimizing deflection and ensuring concentric running; a better alternative to cantilever designs

### Versatile

- Sealed for use in gas and air applications
- Left- or right-hand rotation available
- 4 inlet, 4 exhaust, and 16 housing orientations
- 30–150 psi (2.1–10.3 bars) operation
- Inertia and pre-engaged drives available
- Patented slip-fit motor design makes servicing simple and convenient
- ST1000M version with 2-inch NPT inlet reduces the need for piping changes on some competitive models

### Industry Applications

MARINE



OIL & GAS



OFF-HIGHWAY

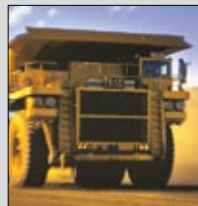

LOCOMOTIVE

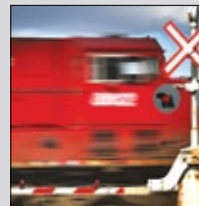

POWER GENERATION



# Turbine Starters

## Dimensions

### Pre-Engaged B & C Ratio

Weight: 76 lbs (34.5 kg)

**Note:** All dimensions shown are for reference only. Specifications subject to change without notice.

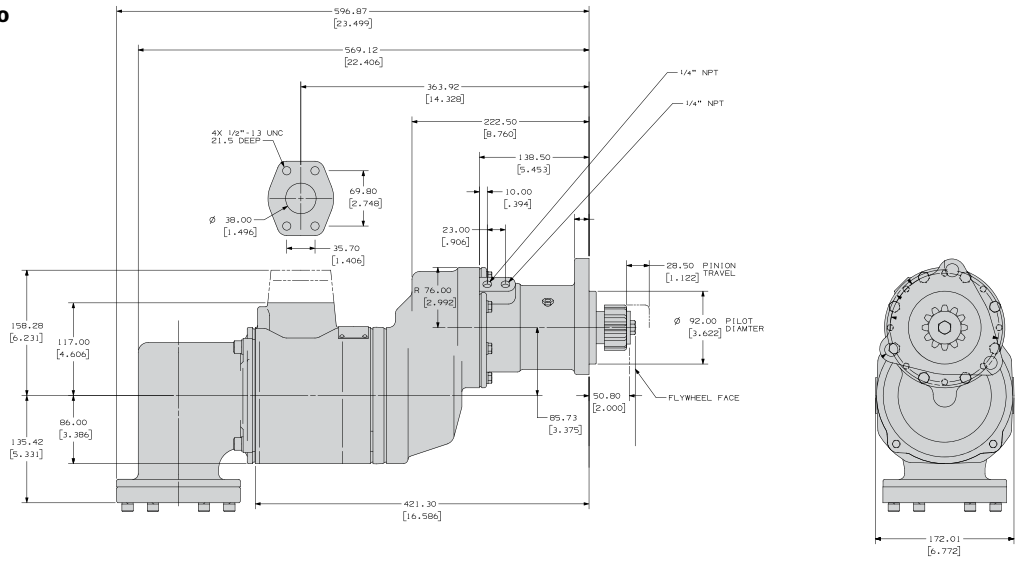

### ST1000M

Weight: 76 lbs (34.5 kg)

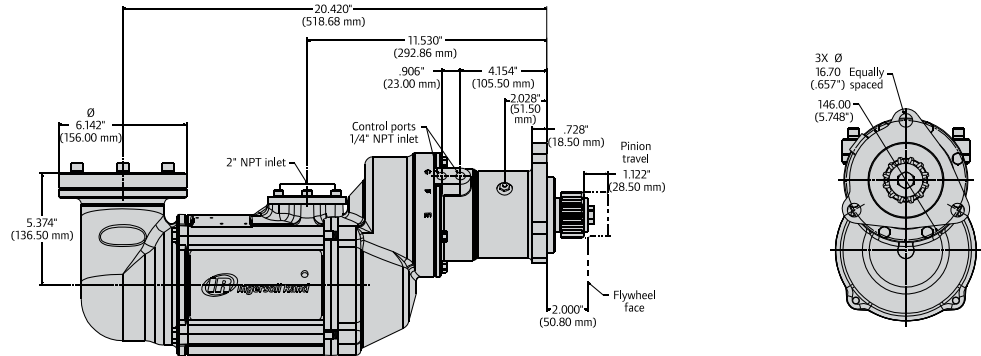

### Pre-Engaged D Ratio

Weight: 102 lbs (46.3 kg)

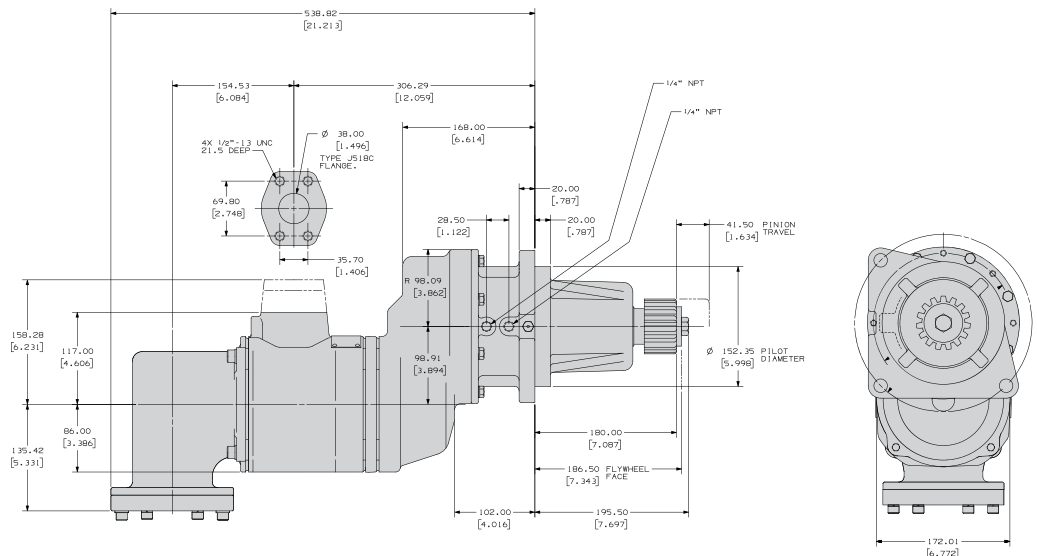

# Turbine Starters

## Performance Information

Pressure psi (bar)	Breakaway Torque ft-lb (Nm)	Speed @ Max HP rpm	Max Power hp (kW)	Flow @ Max HP scfm (L/s)
<b>ST1060 B Ratio</b>				
30 (2)	53 (71)	1175	7 (5)	370 (175)
60 (4)	115 (156)	1550	20 (15)	590 (278)
90 (6)	220 (298)	1780	39 (29)	820 (387)
120 (8)	295 (400)	1900	53 (39)	1050 (496)
150 (10)	353 (478)	2050	70 (52)	1290 (609)
<b>ST1099 B Ratio</b>				
30 (2)	82 (111)	1425	13 (10)	540 (255)
60 (4)	200 (271)	1850	36 (27)	890 (420)
90 (6)	347 (470)	2060	68 (51)	1240 (585)
<b>ST1060 C Ratio</b>				
30 (2)	62 (84)	1025	7 (5)	370 (175)
60 (4)	143 (194)	1350	20 (15)	590 (278)
90 (6)	256 (347)	1515	39 (29)	820 (387)
120 (8)	342 (463)	1675	53 (39)	1050 (496)
150 (10)	409 (554)	1780	70 (52)	1290 (609)
<b>ST1099 C Ratio</b>				
30 (2)	98 (133)	1225	13 (10)	540 (255)
60 (4)	234 (317)	1580	36 (27)	890 (420)
90 (6)	400 (542)	1770	68 (51)	1240 (585)
<b>ST1060 D Ratio</b>				
30 (2)	85 (115)	765	7 (5)	370 (175)
60 (4)	195 (264)	985	20 (15)	590 (278)
90 (6)	326 (442)	1125	39 (29)	820 (387)
120 (8)	462 (626)	1205	53 (39)	1050 (496)
150 (10)	557 (755)	1650	70 (52)	1290 (609)
<b>ST1099 D Ratio</b>				
30 (2)	132 (179)	900	13 (10)	540 (255)
60 (4)	318 (431)	1170	36 (27)	890 (420)
90 (6)	540 (732)	1300	68 (51)	1240 (585)

# Turbine Starters

## Genuine Ingersoll Rand Replacement Kits

Tune Up Kit Part Number	Description
ST700P-TK7	Pre-engaged Tune Up Kit
ST700I-TK6	Inertia Tune Up Kit
ST700D-TK8	D Ratio Tune Up Kit
ST1000-SK1	Seal Kit
ST1000-GK1	Planetary Gear Kit
ST1000R-K53-37	Rotor Replacement Kit (RH)

Tune Up Kit Part Number	Description
ST1000L-K53-37	Rotor Replacement Kit (LH)
ST1000-K24	Rotor Bearing Kit
ST1000R-K212	Motor Adapter Kit (RH)
ST1000L-K212	Motor Adapter Kit (LH)
ST1000K-562	Straight Exhaust Kit
ST1000K-350	Elbow Exhaust Kit



ST700P-TK7 Parts



ST1000-SK1 Parts

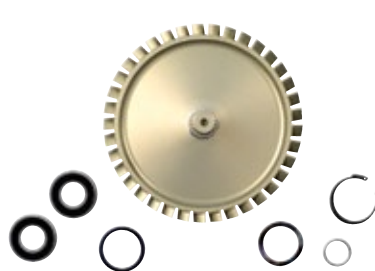

ST1000R-K53-37  
and ST1000L-K53-37 Parts



ST1000K-350 Part

## Parts and Accessories

Part #	Description
--------	-------------



ST700-K166 Inlet Flange Kit



ST700-K351 Exhaust Flange Kit



SRV150 1-1/2" Relay Valve for Air



SRV150SS 1-1/2" Gas Rated Stainless Steel Relay Valve



\*ST900-267H/150 1-1/2" Strainer Housing

ST900-267H/200 2" Strainer housing



\*ST900-266/150-HP 1-1/2" Strainer (50 microns)

ST900-266/200-HP 2" Strainer (50 microns)

Part #	Description
--------	-------------



SMB-618 Push Button Valve



SMB-G618 Gas Rated Push Button Valve



38600714 (RR152-F30) High Pressure Regulator Relay Valve (for use with air only) 1.5" 90 Degree

38754917 (RR152-F30-14) High Pressure Regulator Relay Valve (for use with air only) 1.5" In-line

16675845 (RR250-F30) High Pressure Regulator Relay Valve (for use with air only) 2.5" In-line

\*For complete filter (strainer + housing), please order ref ST900-267/150-HP



# Superior Engineering, Legendary Performance

## Vane Starters

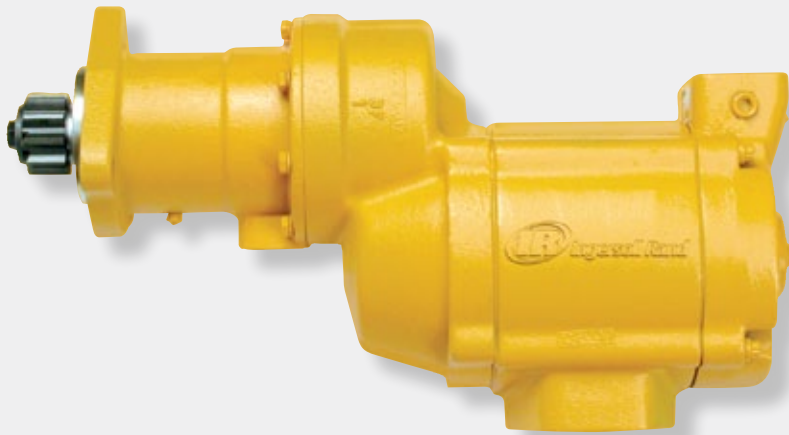

With their simple, rugged design, easy maintenance, and legendary durability, Ingersoll Rand vane starters reign as the most commonly used air starters in the world. Our vane motors develop maximum horsepower at speeds as low as 5000 RPM plus require only a small amount of lubrication for maximum life. This ability to thrive at lower speeds improves each motor's bearing life, minimizes planetary gear reduction and delivers more torque per pound than other displacement motors.

- High torque, lower RPMs
- Easy field serviceability
- Modular design shares components with turbine starters

Reliability and high-efficiency at a low cost have made our 150 BM and SS800 models the benchmark starters in their class.



# Vane Starters

## Vane Starters Selection Guide

For Diesel Engine Displacement (liters)	Catalog Section	Series	Gear Ratio	Extended Starting Capability (>10 sec.)	Max Power (hp)	Max Pressure psi (bar)	Air Consumption at Max HP scfm (L/s)	Engagement Type**	Inlet Size (NPT)	Exhaust Size (NPT)	Gas Sealed
<b>No Lubrication Required</b>											
1 to 10	G	SS100*	E	No	15	150 (10.3)	415 (196)	Pre-Engaged or Inertia	1"	1 <sup>1</sup> / <sub>2</sub> "	Yes
<b>Lubrication Required</b>											
8 to 27	G	150BMG	E	No	32	150 (10.3)	680 (321)	Inertia	1 <sup>1</sup> / <sub>4</sub> "	1 <sup>1</sup> / <sub>4</sub> "	Yes
8 to 27	G	150BMP	E	No	32	150 (10.3)	680 (321)	Pre-Engaged	1 <sup>1</sup> / <sub>4</sub> "	1 <sup>1</sup> / <sub>4</sub> "	No
15 to 32	G	150BMP	D	No	32	150 (10.3)	680 (321)	Pre-Engaged	1 <sup>1</sup> / <sub>4</sub> "	1 <sup>1</sup> / <sub>4</sub> "	No
8 to 27	F	SS350G	E	No	36	150 (10.3)	900 (425)	Pre-Engaged	1 <sup>1</sup> / <sub>4</sub> "	1 <sup>1</sup> / <sub>2</sub> "	Yes
16 to 130	H	SS810	B	No	80	150 (10.3)	1700 (802)	Inertia	1 <sup>1</sup> / <sub>2</sub> "	2 <sup>1</sup> / <sub>2</sub> "	Yes
16 to 130	H	SS815	B	No	80	150 (10.3)	1700 (802)	Pre-Engaged	1 <sup>1</sup> / <sub>2</sub> "	2 <sup>1</sup> / <sub>2</sub> "	Yes
80 to 200	H	SS825	C	No	75	150 (10.3)	1350 (637)	Pre-Engaged	1 <sup>1</sup> / <sub>2</sub> "	2 <sup>1</sup> / <sub>2</sub> "	Yes
160 to 320	H	SS850	D	No	75	150 (10.3)	1275 (602)	Pre-Engaged	1 <sup>1</sup> / <sub>2</sub> "	2 <sup>1</sup> / <sub>2</sub> "	Yes

These figures are only a guide. For difficult-to-start engines or for operation under adverse conditions, use the next more powerful starter. For 2-stroke diesel engines, these figures may be multiplied by 1.5. Ex: an SS100 could be used on a 15 liter 2-stroke diesel engine. For carbureted (gas) engines, these figures may be doubled. Ex: a 150BMP could be used on a 54 liter gas engine. Note 1 liter = 61.02 in<sup>3</sup>.

\*\* There are two basic types of air starters: pre-engaged and inertia. With pre-engaged starters, the drive pinion is completely engaged with the engine ring gear before the starter begins to crank the engine. With an inertia starter, the rotating drive pinion engages the engine ring gear simultaneously with the initial cranking of the engine.

\*The SS100 is lube-free

# Vane Starters

## SS100 Series



**For engine displacement of:**  
Diesel—0 to 600 CID (0 to 10 liters)  
Carbureted—0 to 1200 CID (0 to 20 liters)

### Features/Benefits

- Powerful, revolutionary lube-free vane motor can be used with air or natural gas
- Alloy steel motor components ensure reliability in harsh conditions
- Offset-gear design for rugged power transfer and easy field service
- Class-leading starting torque for engines up to 10 liters
- One starter replaces the 3BM, 5BM and SS175 series

### Versatile

- One size fits engines up to 10 liters to lower cost and reduce inventory
- Compact design and flexible mounting for easy fit-up
- Standard and metric pinions fit most manufacturers' engines
- Overhung pinion and 360° flange design for easy installation
- Dependable accessories including valves, mufflers and deflectors

### Industry Applications

MARINE



OIL & GAS



OFF-HIGHWAY



LOCOMOTIVE

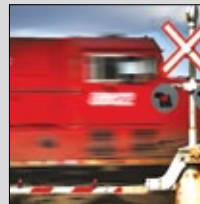

POWER GENERATION



# Vane Starters

## Dimensions

### SS100

Weight: 28lbs (12.7 kg)

**Note:** All dimensions shown are for reference only. Specifications subject to change without notice.

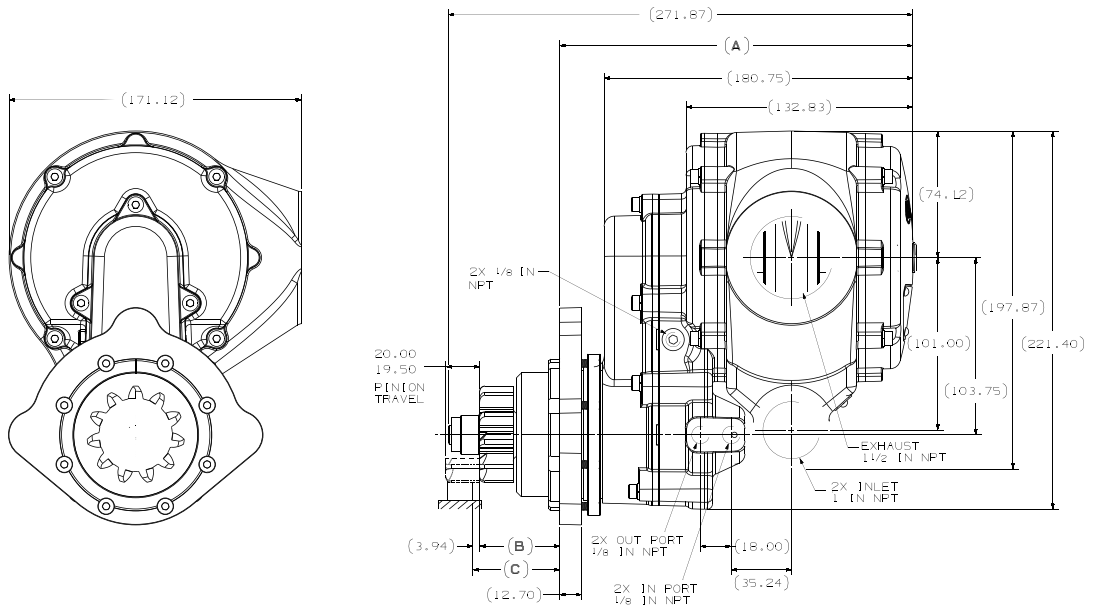

## Housing Orientations

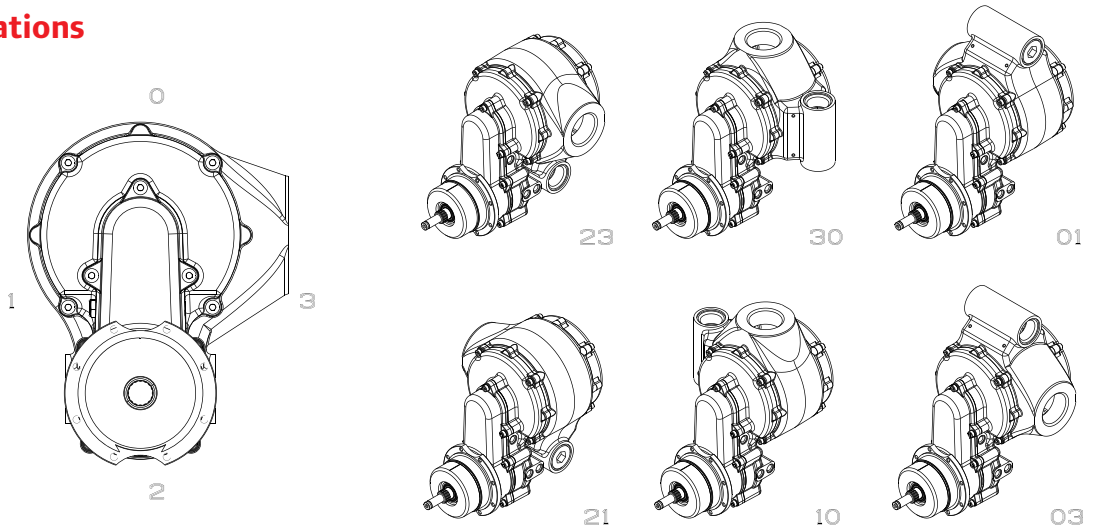

## Performance Information

Pressure psi (bar)	Breakaway Torque ft-lb (Nm)	Speed @ Max HP rpm	Max Power hp (kW)	Flow @ Max HP scfm (L/s)
<b>SS100</b>				
30 (2.1)	16 (22)	1290	2.3 (1.7)	110 (52)
60 (4.1)	39 (53)	1625	6.4 (4.8)	215 (101)
90 (6.2)	55 (75)	1800	9.6 (7.2)	315 (149)
120 (8.3)	75 (102)	1900	13.8 (10.3)	415 (196)
150 (10.3)	75 (102)	1900	13.8 (10.3)	415 (196)

# Vane Starters

## Model Coding

**SS100P 01 R 071-2 3**

Flange Code











Exhaust Orientation

Pinion Code

Inlet Orientation

## Parts and Accessories

Part #	Description
 SRV100	1" Relay Valve
 SRV100-SMB	1" Relay Valve with Push Button
 SRV150SS	1-1/2" Gas Rated Relay Valve
 SS350-A674	1-1/2" Muffler
 SS350-A735	Exhaust Deflector

Part #	Description
 150BMP-1051B	1/4" 12V Solenoid Valve
 150BMP-2451B	1/4" 24V Solenoid Valve
 SMB-618	Push Button Valve
 SMB-G618	Push Button Valve for Natural Gas
 ST900-267H/100	1" Strainer Housing
 *ST900-267H/150	1-1/2" Strainer Housing
 ST900-267H/200	2" Strainer Housing
 ST900-266/100-HP	1" Strainer (50 microns)
 *ST900-266/150-HP	1-1/2" Strainer (50 microns)
 *ST900-266/200-HP	2" Strainer (50 microns)

## Genuine Ingersoll Rand Replacement Kits

Tune Up Kit Part Number	Description
SS100-TK1	Tune Up Kit
SS100-GK1	Gear Kit
SS100-TK2	Drive Housing Seal Kit
SS100-K299	Drive Kit
SS100-K299-18	Pinion Hardware Kit
SS100-K301-01	Flange Kit, SAE 01
SS100-K301-03	Flange Kit, SAE 03
SS100-K301-04	Flange Kit, SAE 04
SS100-K301-GM	Flange Kit, GM



SS100-TK1 Parts



SS100-GK1 Parts

\*For complete filter (strainer + housing), please order ref ST900-267/150-HP

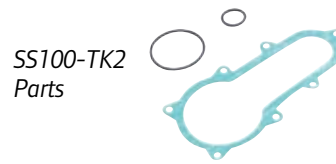

SS100-TK2 Parts



SS100-K299 Parts



SS100-K299-18 Parts



SS100-K301-01 Parts



SS100-K301-03 Parts



SS100-K301-GM Parts



SS100-K301-04 Parts

# Vane Starters

## 150BM Series

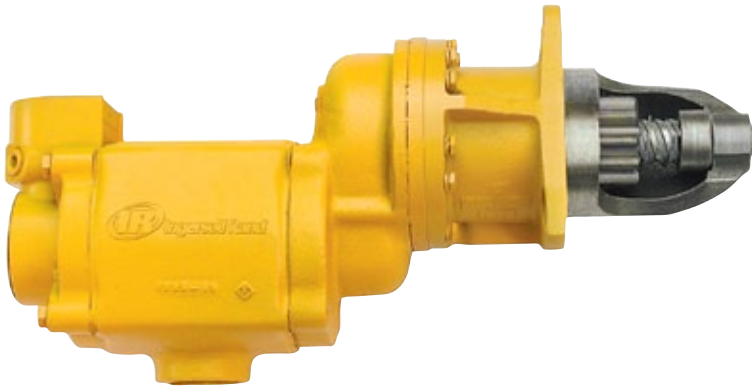

**For engine displacement of:**  
 Diesel—500 to 2000 CID (8 to 32 liters)  
 Carbureted—1000 to 4000  
 CID (16 to 64 liters)

### Features/Benefits

- Powerful 32 hp motor
- The leading mid-range starter design, the standard by which all others are measured
- Simple design ensures rugged dependability and ease of maintenance
- Multiple offset gear ratios: E = 3.46:1; D = 3.94:1
- Backcap ports for injection lubricating

### Versatile

- 150BMG sealed for use in air or gas applications
- Offset design for simple mounting
- Inertia and pre-engaged starters available
- 4 inlet, 4 exhaust, and 18 drive housing orientations
- 90-150 psi (6.2-10.3 bars) operation
- Left- and right-hand rotation available

### Industry Applications



### Model Coding

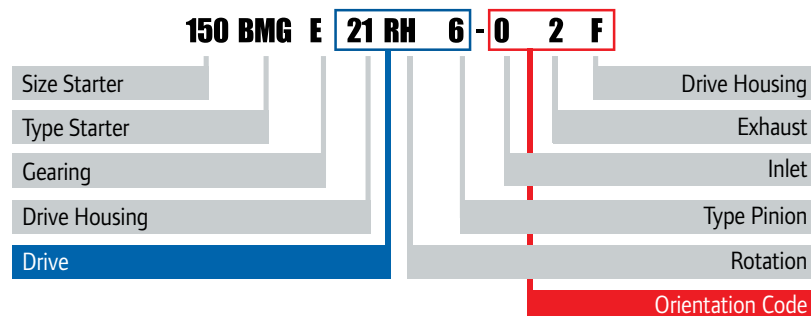

# Vane Starters

## Dimensions

### 150BMG/150BMP

Weight:

150BMG 38 lbs (17.2 kg)

150BMP 40 lbs (18.1 kg)

**Note:** All dimensions shown are for reference only. Specifications subject to change without notice.

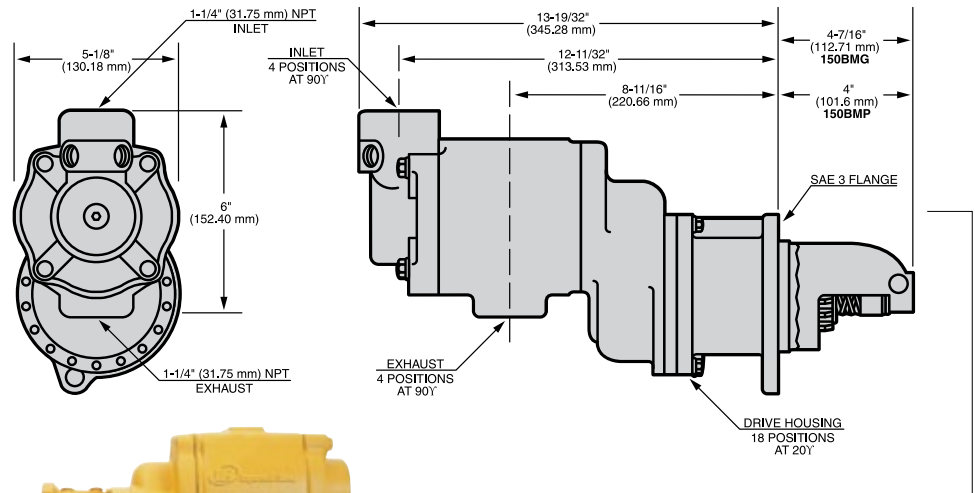

### 150BMPD

Weight: 40 lbs (15.9 kg)

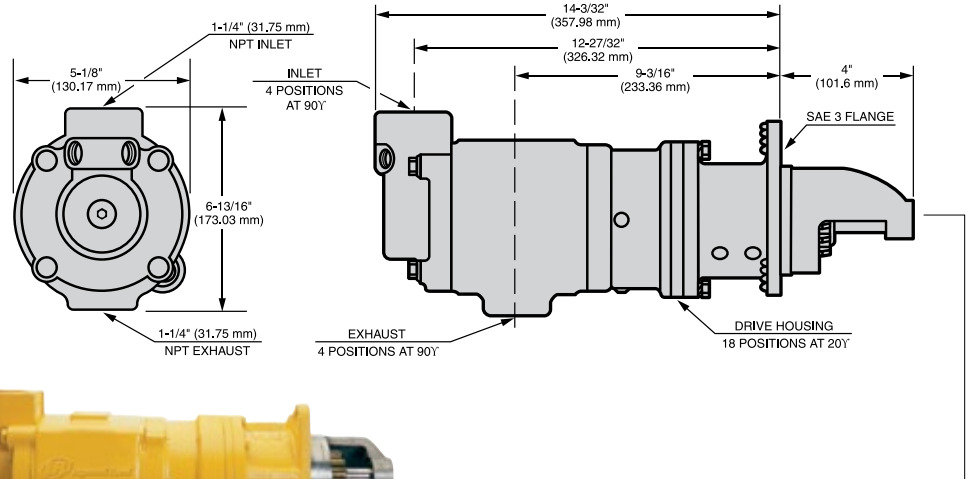

## Performance Information

Pressure psi (bar)	Breakaway Torque ft-lb (Nm)	Speed @ Max HP rpm	Max Power hp (kW)	Flow @ Max HP scfm (L/s)
<b>150BMGE/150BMPE</b>				
90 (6.2)	100 (136)	1700	16 (12)	380 (179)
120 (8.3)	130 (176)	1900	24 (18)	500 (236)
150 (10.3)	155 (210)	2200	32 (24)	680 (321)
<b>150BMPD</b>				
90 (6.2)	110 (149)	1500	16 (12)	370 (175)
120 (8.3)	145 (196)	1700	24 (18)	500 (236)
150 (10.3)	175 (237)	1900	32 (24)	650 (307)

# Vane Starters

## Genuine Ingersoll Rand Replacement Kits

Tune Up Kit Part Number	Description
150BM-TK2	150BM Products
150LF-TK2	150LF Products (uses 150LF-42 vanes)
150LF-TK1	150 Motor Gasket Kit for all vane motor 150 products
150BMPD-TK1	150BMPD Products

### Parts



150LF-TK1 Parts





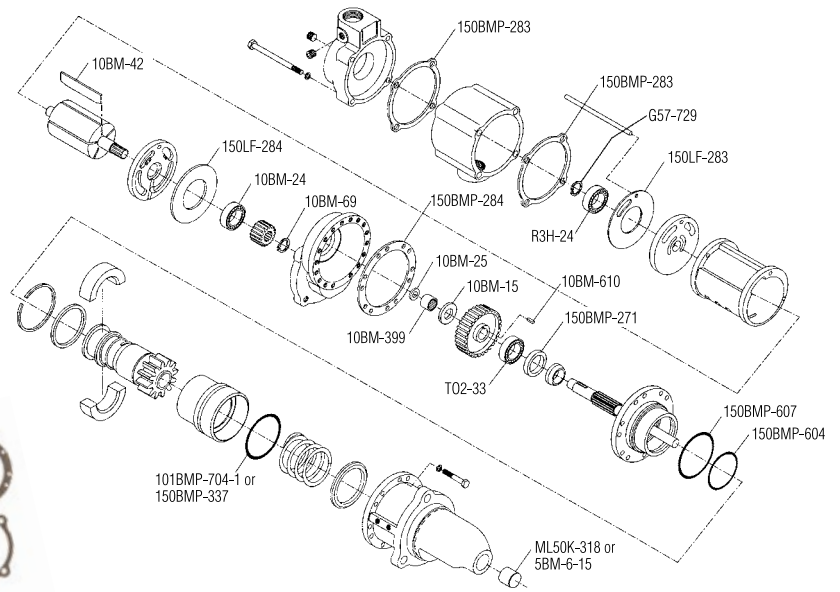





150BM-TK2 Parts



Exploded View of 150BM-TK2 Part Location

### Parts and Accessories

Part #	Description
 150BM-A674	1 1/4" Muffler
 150BMP-1051B	1/4" 12 V Solenoid Valve
 150BMP-2451B	1/4" 24 V Solenoid Valve
 NL-24-8	In-Line Lubricator
 HDL2 (Stationary)	3/8" NPT Lubricator (1.3 cc)
 HDL3 (Transportation)	3/8" NPT Lubricator (0.4 cc)
 SMB-G618	Gas Rated Push Button Valve
 SMB-618	Push Button Valve

Part #	Description
 SRV150SS	1-1/2" Gas Rated Relay Valve
 SRV125T	1-1/4" Relay Valve for Vehicular Applications
 SRV125	1-1/4" Relay Valve for Stationary Applications
 150BMP-1058	Gladhand
 *ST900-267H/150	1-1/2" Strainer Housing
 ST900-267H/200	2" Strainer Housing
 *ST900-266/150-HP	1-1/2" Strainer (50 microns)
 ST900-266/200-HP	2" strainer (50 microns)
 150BMP-1064	1/8", 150 psi Pressure Gauge
150BM-A735	Road Splash Deflector

\*For complete filter (strainer + housing), please order ref ST900-267/150-HP



# Vane Starters

## SS350 Series



**For engine displacement of:**  
 Diesel—200 to 1200 CID (3 to 20 liters)  
 Carbureted—400 to 2400 CID (6 to 40 liters)

### Features/Benefits

- Rugged 36 hp motor on SS350
- Overhung pre-engaged pinion design for fit-up flexibility
- Backcap ports for injection lubricating

### Versatile

- Sealed for use in air or gas applications
- Compact, lightweight design makes installation easier
- Left- or right-hand rotation available
- 4 inlet, 4 exhaust, and 12 housing orientations
- 30-150 psi (2.1-10.3 bars) operation
- SAE 01 and SAE03 mounting flanges fit most worldwide manufacturers' engines

### Industry Applications

MARINE



OIL & GAS



OFF-HIGHWAY



TRANSPORTATION



POWER GENERATION



### Model Coding

**SS350 G E 03 R 31 XX - 024**

Size Starter

Gas Sealed

Gear Ratio

SAE No. Mounting Flange

Orientation

SR = Spark Resistant

Pinion Coding

Rotation L or R

# Vane Starters

## Dimensions

### SS350G

Weight: 33 lbs (15.0 kg)

**Note:** All dimensions shown are for reference only. Specifications subject to change without notice.

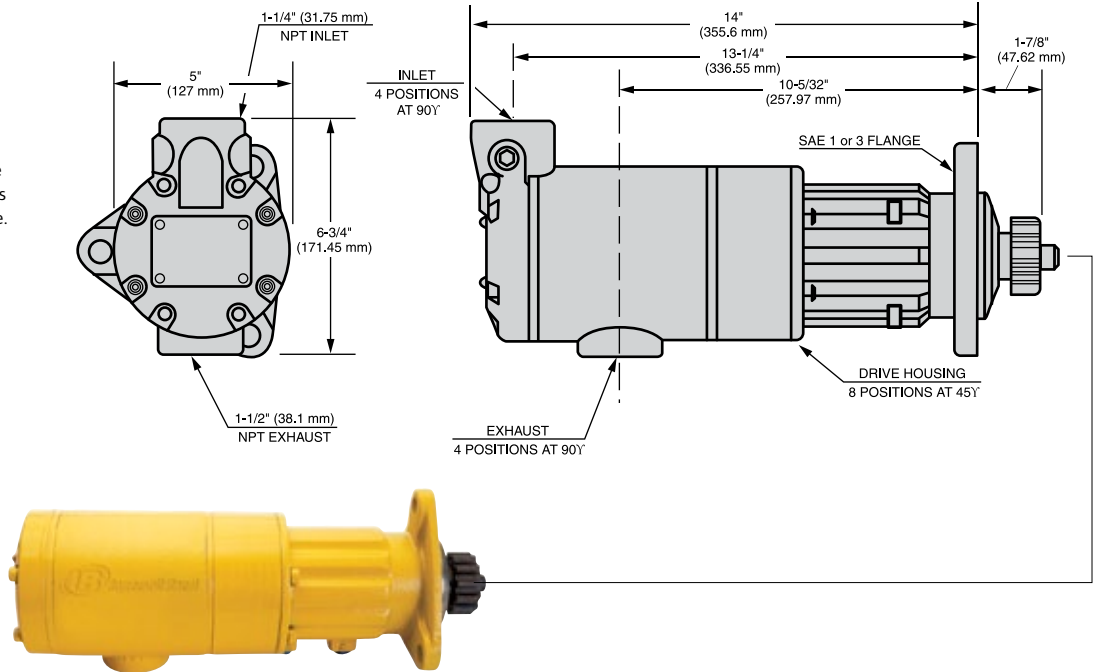

## Performance Information

Pressure psi (bar)	Breakaway Torque ft-lb (Nm)		Speed @ Max HP rpm		Max Power hp (kW)	Flow @ Max HP scfm (L/s)
	B Ratio	E Ratio	B Ratio	E Ratio		
90 (6.2)	70 (95)	100 (136)	2900	2000	19 (14)	525 (248)
120 (8.3)	90 (122)	130 (176)	3100	2200	27 (20)	750 (354)
150 (10.3)	110 (149)	160 (217)	3400	2400	36 (27)	900 (425)

# Vane Starters

## Genuine Ingersoll Rand Replacement Kits

Tune Up Kit Part Number	Description
SS350-TK2	SS350 Tune Up Kit





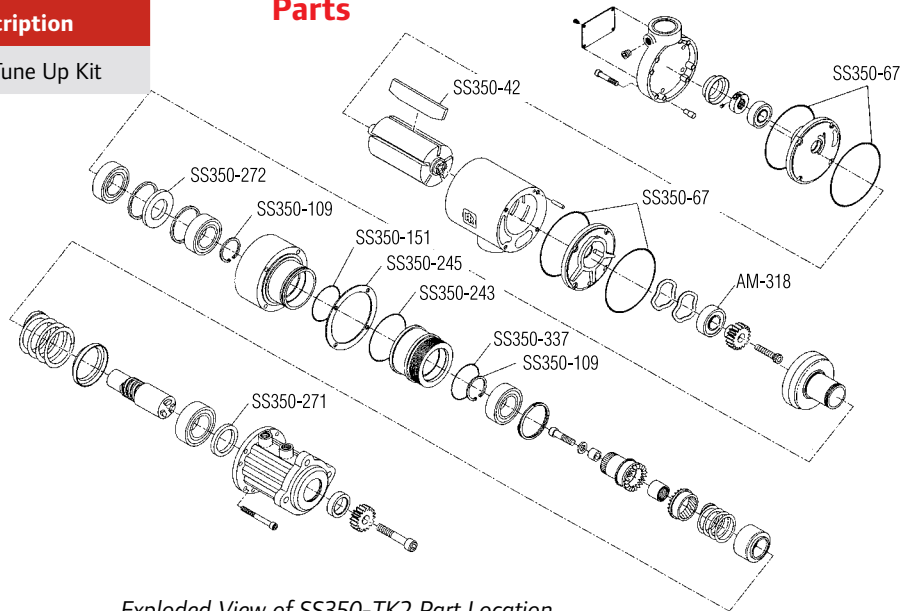

SS350-TK2 Parts

### Parts



Exploded View of SS350-TK2 Part Location

## Parts and Accessories

Part #	Description
 SS350-A674	1 1/2" Muffler
 150BMP-1051B	1/4" 12 V Solenoid Valve
 150BMP-2451B	1/4" 24 V Solenoid Valve
 NL-24-8	In-Line Lubricator
 HDL2 (Stationary)	3/8" NPT Lubricator (1.3 cc)
 HDL3 (Transportation)	3/8" NPT Lubricator (0.4 cc)
 SMB-G618	Gas Rated Push Button Valve
 SMB-618	Push Button Valve

Part #	Description
 SRV150SS	1-1/2" Gas Rated Relay Valve
 SRV125T	1-1/4" Relay Valve for Vehicular Applications
 SRV125	1-1/4" Relay Valve for Stationary Applications
 150BMP-1058	Gladhand
 150BMP-1064	1/8", 150 psi Pressure Gauge
 *ST900-267H/150	1-1/2" Strainer Housing
 ST900-267H/200	2" Strainer Housing
 *ST900-266/150-HP	1-1/2" Strainer (50 microns)
 ST900-266/200-HP	2" Strainer (50 microns)
 150BMP-1056	1/2" Check Valve

\*For complete filter (strainer + housing), please order ref ST900-267/150-HP

# Vane Starters

## SS800 Series



**For engine displacement of:**  
 Diesel—1000 to 20,000 CID (16 to 320 liters)  
 Carbureted—2000 to 40,000  
 CID (32 to 640 liters)

### Features/Benefits

- Powerful 75 hp motor
- The leading large-frame starter design, the standard by which all others are measured
- Simple design ensures rugged dependability and ease of maintenance
- Multiple offset gear ratios: B = 2.18:1; C = 2.53:1; D = 3.44:1
- Backcap ports for injection lubricating

### Versatile

- All models sealed for use in air or gas applications
- Offset design for simple mounting
- Inertia (SS810) and pre-engaged (SS815, SS825 and SS850) starters available
- 4 inlet, 4 exhaust, and 16 drive housing orientations
- 90-150 psi (6.2-10.3 bars) operation
- Left- and right-hand rotation available

### Industry Applications



### Model Coding

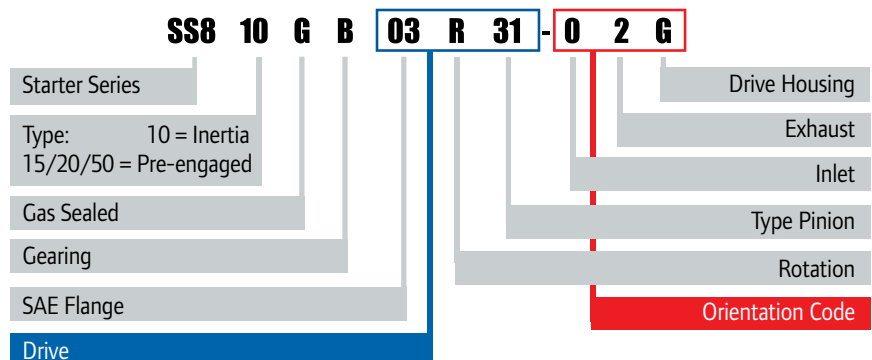

# Vane Starters

## Dimensions

**Note:** All dimensions shown are for reference only. Specifications subject to change without notice.

**SS810G**  
Weight: 93 lbs (42.2 kg)

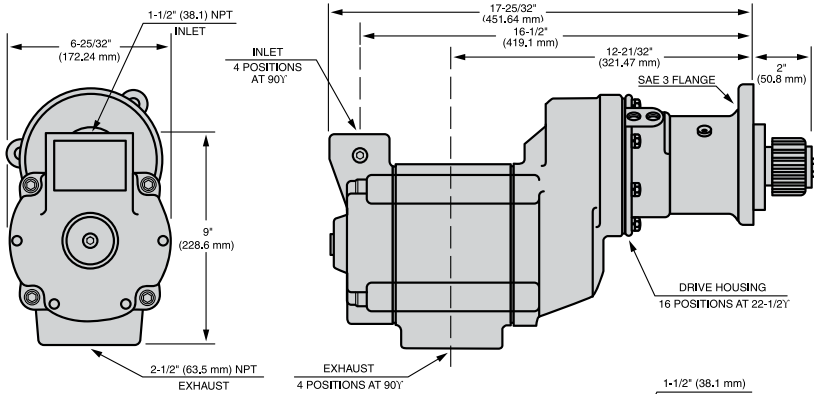
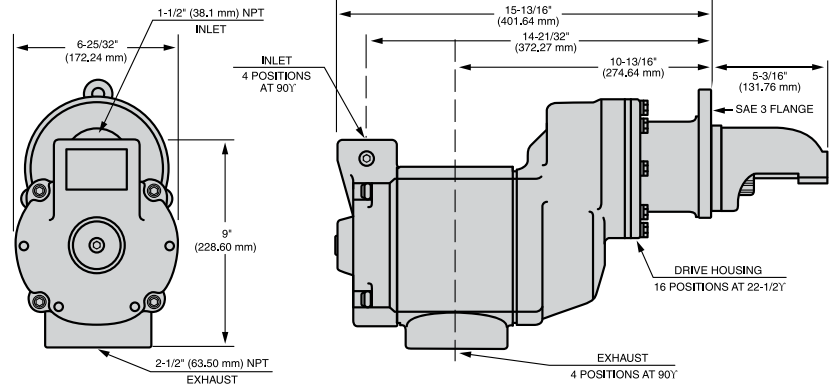

**SS815G and SS825G**  
Weight: SS815G 93 lbs (31.3 kg)  
SS825G 95 lbs (43.1 kg)

**SS850G**  
Weight: 123 lbs (55.8 kg)

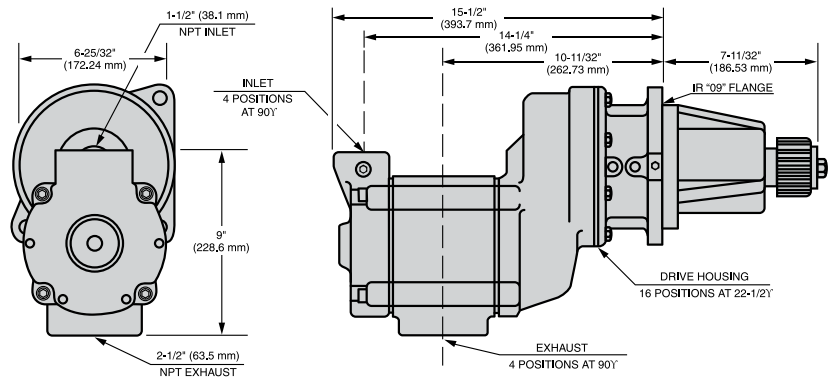

## Performance Information

Pressure psi (bar)	Breakaway Torque ft-lb (Nm)	Speed @ Max HP rpm	Max Power hp (kW)	Flow @ Max HP scfm (L/s)
<b>SS810 and SS815</b>				
90 (6.2)	170 (230)	2700	45 (34)	1100 (519)
120 (8.3)	205 (278)	2800	58 (43)	1250 (590)
150 (10.3)	250 (339)	3200	75 (56)	1700 (802)
<b>SS825</b>				
90 (6.2)	200 (271)	2300	45 (34)	900 (425)
120 (8.3)	240 (325)	2400	58 (43)	1100 (519)
150 (10.3)	300 (407)	2700	75(56)	1700 (802)
<b>SS850</b>				
90 (6.2)	260 (352)	1600	45 (34)	800 (378)
120 (8.3)	340 (461)	1800	58 (43)	1000 (472)
150 (10.3)	415 (562)	1900	75(56)	1275 (602)

# Vane Starters

## Genuine Ingersoll Rand Replacement Kits

Tune Up Kit Part Number	Description
SS800-TK2	SS815 and SS825 Tune Up Kit
SS810-TK2	SS810 Tune Up Kit
SS810-TK2	SS850 Tune Up Kit

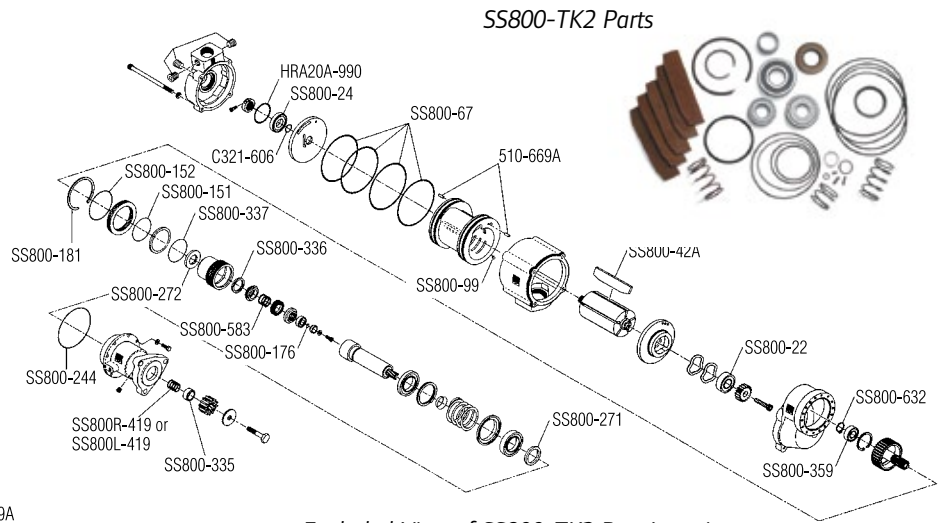

Exploded View of SS800-TK2 Part Location

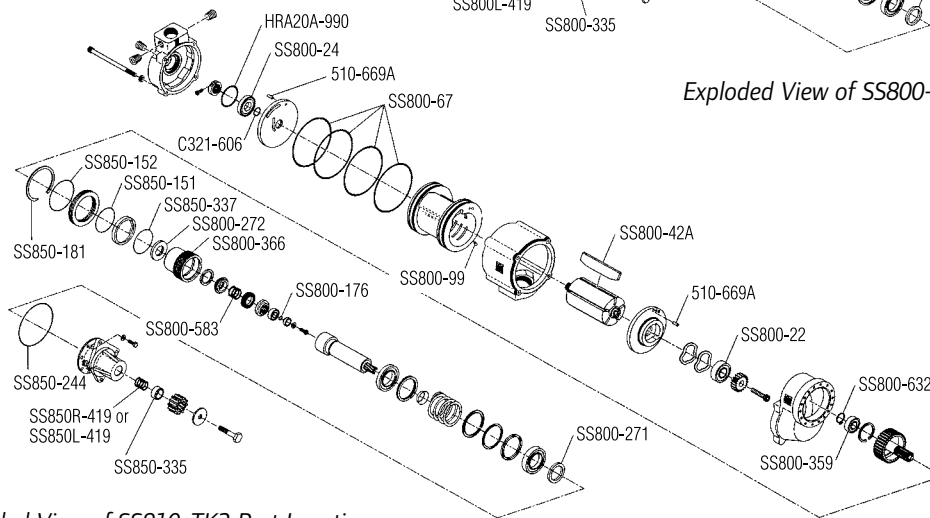









Exploded View of SS810-TK2 Part Location



SS810-TK2 Parts

## Parts and Accessories

Part #	Description
 SS800-A674	2-1/2" Muffler
 150BMP-1051B	1/4" 12 V Solenoid Valve
 150BMP-2451B	1/4" 24 V Solenoid Valve
 NL-24-8	In-Line Lubricator
 HDL2 (Stationary)	3/8" NPT Lubricator (1.3 cc)
 HDL3 (Transportation)	3/8" NPT Lubricator (0.4 cc)
 SMB-G618	Gas Rated Push Button Valve
 SMB-618	Push Button Valve

Part #	Description
 SRV150	1-1/2" Relay Valve for Air Applications
 SRV150SS	1-1/2" Gas Rated Relay Valve
 150BMP-1058	Gladhand
 150BMP-1064	1/8", 150 psi Pressure Gauge
 *ST900-267H/150	1-1/2" Strainer Housing
 ST900-267H/200	2" Strainer Housing
 *ST900-266/150-HP	1-1/2" Strainer (50 microns)
 ST900-266/200-HP	2" strainer (50 microns)

\*For complete filter (strainer + housing), please order ref ST900-267/150-HP



# Vane Starters

## Dimensions

**Note:** All dimensions shown are for reference only. Specifications subject to change without notice.

**TS725GBDE-LE**  
Weight: 80 lbs (36.3 kg)

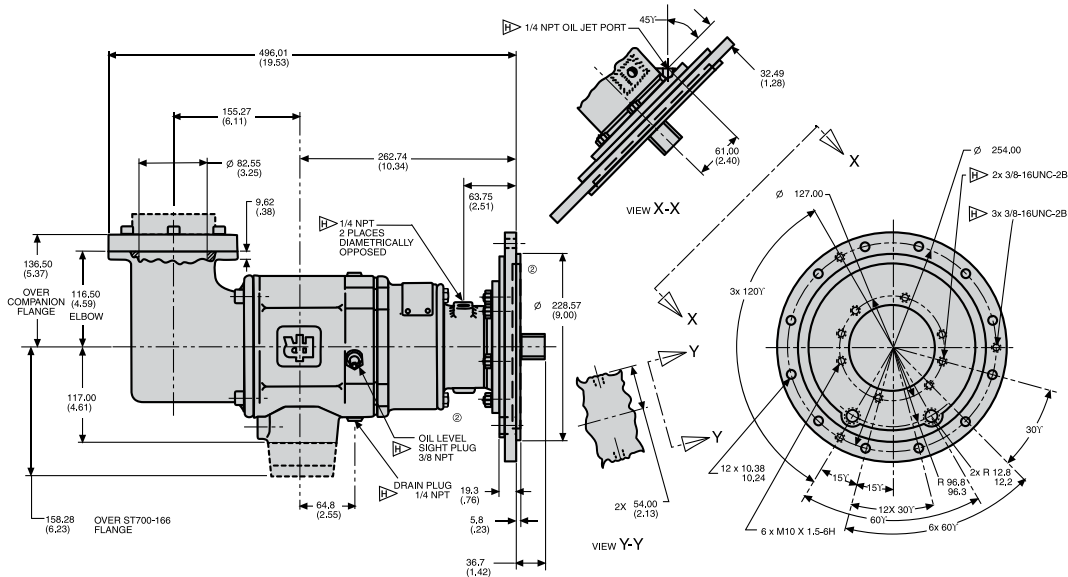

**Inlet Flange Kit (ST700-K166)**

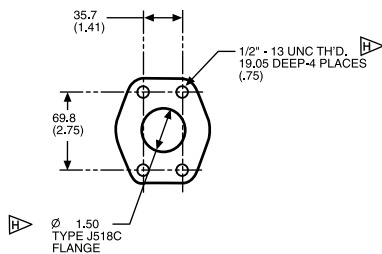

**TS799BBEF-LE**  
Weight: 70 lbs (31.8 kg)

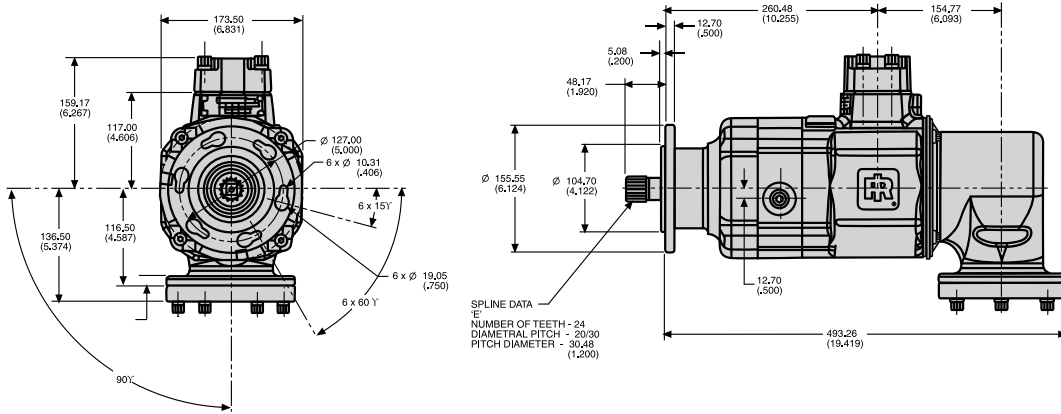

**TS799BBEF-LM**  
Weight: 62 lbs (28.1 kg)

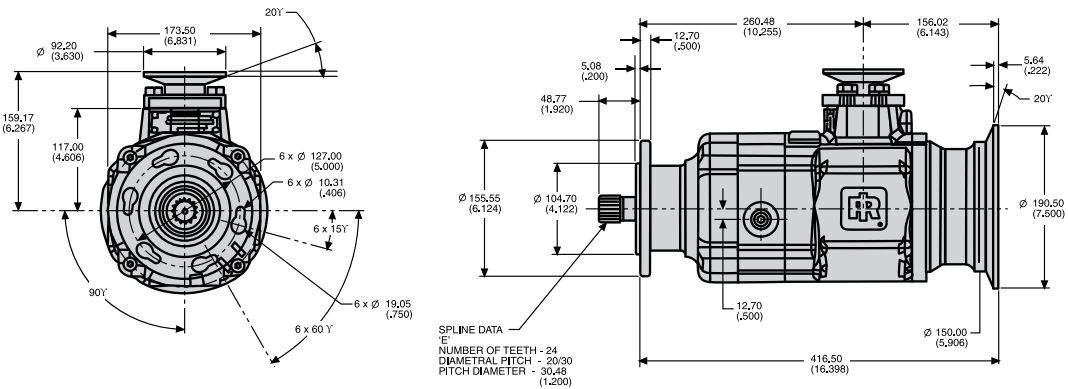



# Vane Starters

## Dimensions

**Note:** All dimensions shown are for reference only. Specifications subject to change without notice.

**TS799GBFD-L**  
Weight: 70 lbs (31.8 kg)

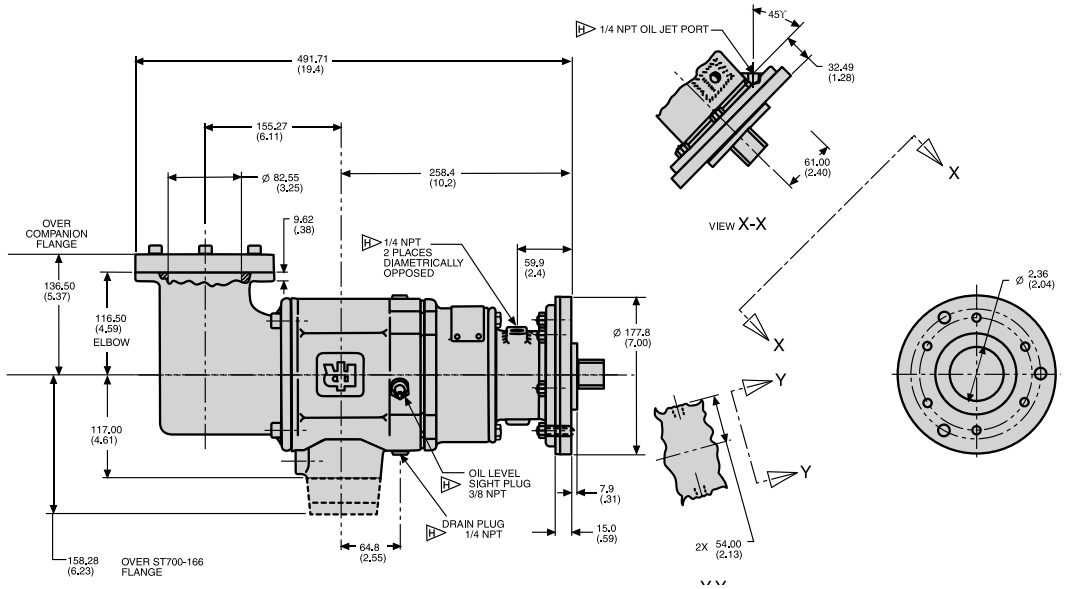

**TS999GZCD-LE**  
Weight: 70 lbs (31.8 kg)

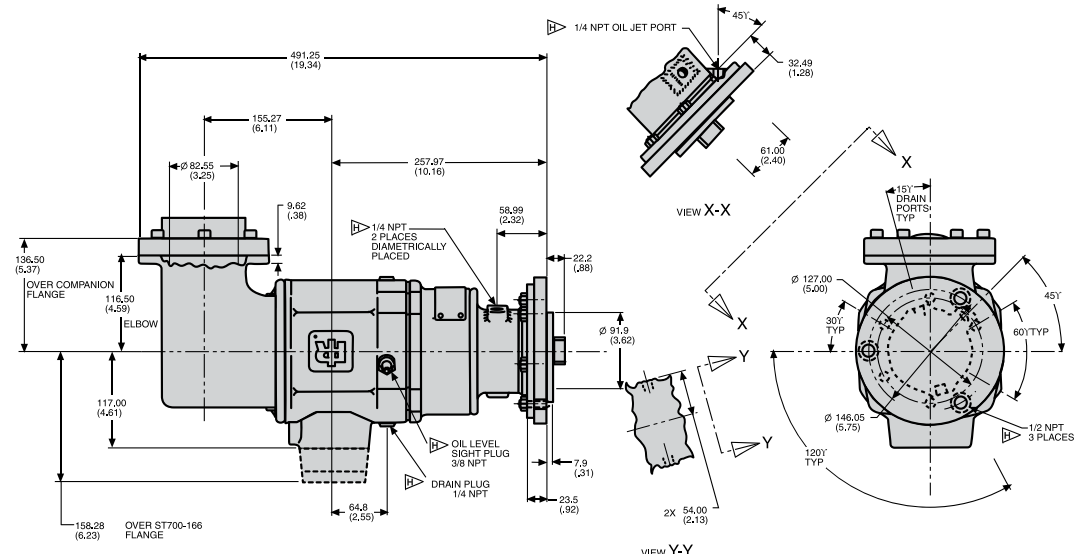

**TS999GZFA-L**  
Weight: 58 lbs (26.3 kg)

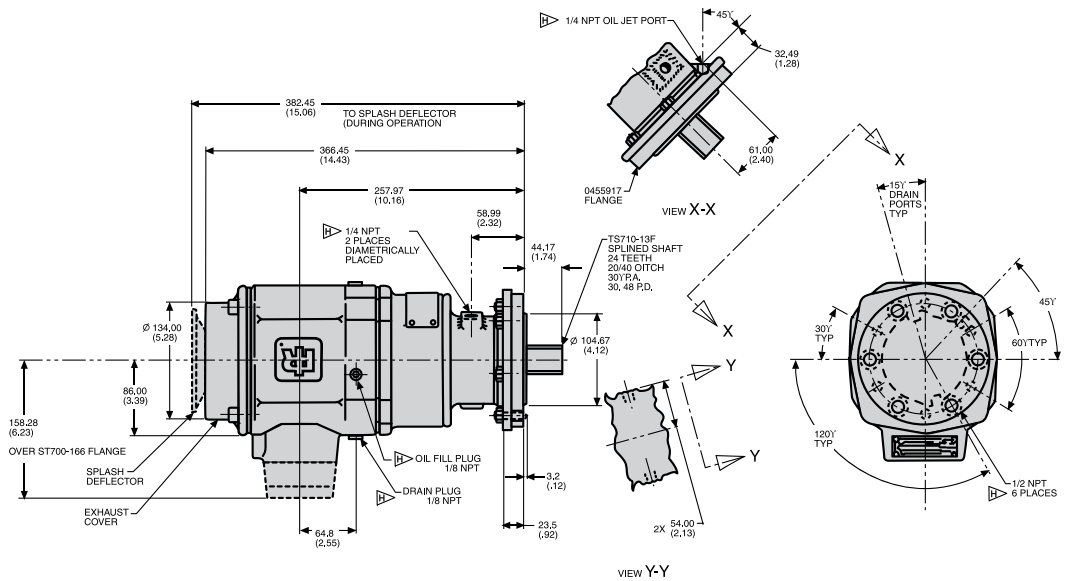

# Vane Starters

## Dimensions

**Note:** All dimensions shown are for reference only. Specifications subject to change without notice.

**TS1400 Turbine Units**  
Weight: 124 lbs (56.2 kg)

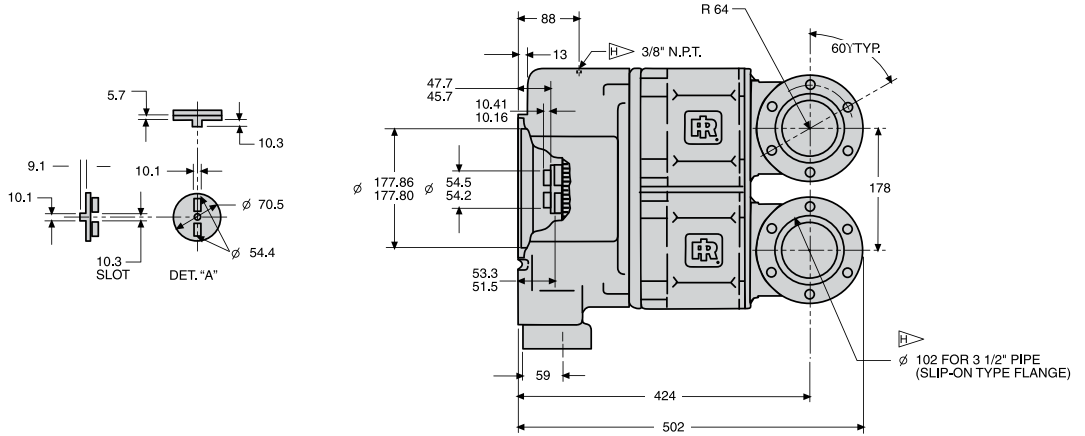

## Single Motor Performance Information

Pressure psi (bar)	Breakaway Torque ft-lb (Nm)	Speed @ Max HP rpm	Max Power hp (kW)	Flow @ Max HP scfm (L/s)
<b>TS725</b>				
90 (6.2)	110 (149)	2000	18 (13)	330 (156)
150 (10.3)	180 (243)	2300	40 (30)	515 (243)
225 (15.5)	270 (365)	2500	65 (49)	750 (354)
<b>TS750</b>				
90 (6.2)	170 (230)	2200	30 (22)	850 (401)
120 (8.3)	240 (325)	2300	50 (37)	990 (467)
150 (10.3)	300 (407)	2500	70 (52)	1210 (571)
<b>TS799G</b>				
60 (4.1)	250 (339)	2400	55 (41)	1050 (496)
90 (6.2)	310 (420)	2500	70 (52)	1400 (661)
<b>TS799B</b>				
150 (10.3)	570 (773)	2500	130 (97)	2200 (1038)
<b>TS999</b>				
90 (6.2)	125 (169)	5500	71 (53)	1300 (614)

## Dual Motor Performance Information

Part Number	Solar Part Number	Max Pressure psi (bar)	Breakaway Torque ft-lb (Nm)	Speed @ Max HP rpm	Max Power hp (kW)	Flow @ Max HP scfm (L/s)	Motor Arc
<b>TS1400</b>							
TS1401-102	190475-102	225 (15.5)	420 (567)	3100	124 (93)	1700 (802)	25%
TS1435	190475-301	225 (15.5)	459 (620)	3882	141 (105)	1900 (896)	35%
TS1450	190475-401	150 (10.3)	506 (683)	3034	146 (109)	2500 (1179)	50%

# Vane Starters

## TS Engine Selection Guide

Engine	Part Number	Solar Part Number	Max Pressure psi (bar)
<b>Solar Saturn</b>	TS725GBBE-LE	190716-200	225 (15.5)
	TS725GBDE-LE	190716-100	225 (15.5)
	TS750GBBE-LE	-	150 (10.3)
<b>Solar Centaur</b>	TS1435	190475-301	225 (15.5)
	TS1450	190475-401	180 (12.2)
	TS1401-102	190475-102	225 (15.5)
<b>Solar Taurus</b>	TS1435	190475-301	225 (15.5)
	TS1450	190475-401	180 (12.2)
	TS1401-102	190475-102	225 (15.5)
<b>Allison 570</b>	TS799GBFD-L	-	90 (6.2)
<b>Allison 501-KC</b>	TS999GZFA-L	-	90 (6.2)
<b>Allison 501-KB</b>	TS999GZFA-L	-	90 (6.2)
<b>Garret IE831</b>	TS999GZCD-LE	-	90 (6.2)
<b>Pratt &amp; Whitney GG3/F13, GG4/G14</b>	TS799BBEF-LE	-	150 (10.3)
	TS799BBEF-LM	-	150 (10.3)

This chart is a condensed list of engines that can be cranked with a starter. For a complete list, please contact Ingersoll Rand.

## TS700/TS900 Output Spline Data



TS Part Number	Shaft Output Part Number	Teeth	Diametral Pitch	Pressure Angle	Pitch Diameter
<b>TS725GBBE-LE</b>	TS710-13E	24	20/30	30	30.48
<b>TS725GBDE-LE</b>	TS710-13E	24	20/30	30	30.48
<b>TS750GBBE-LE</b>	TS710-13E	24	20/30	30	30.48
<b>TS799BBEF-LE</b>	TS799-18E	24	20/30	30	30.48
<b>TS799BBEF-LM</b>	TS799-18E	24	20/30	30	30.48
<b>TS799GBFD-L</b>	4612834	16	20/30	30	20.32
<b>TS999GZCD-LE</b>	4612834	16	20/30	30	20.32
<b>TS999GZFA-L</b>	TS710A-13F	24	20/40	30	30.48

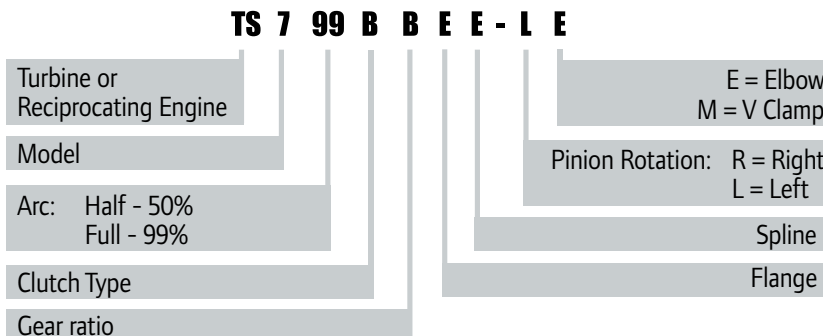



## Model Coding



# Vane Starters

## Parts and Accessories

	Part #	Description
	SRV150	1-1/2" Relay Valve for Air Applications
	SRV150SS	1-1/2" Gas Rated Relay Valve
	150BMP-1064	1/8", 150 psi Pressure Gauge

	Part #	Description
	*ST900-267H/150	1-1/2" Strainer Housing
	ST900-267H/200	2" Strainer Housing
	*ST900-266/150-HP	1-1/2" Strainer (50 microns)
	ST900-266/200-HP	2" Strainer (50 microns)

\*For complete filter (strainer + housing), please order ref ST900-267/150-HP

## Genuine Ingersoll Rand Replacement Kits

Tune Up Kit Part Number	Description
<b>TS1400</b>	
TS1400-TK1	Seal and O-Ring Kit
TS1401-RM1	Seals, Bearings, and 2-25% Arc Motors
TS1401-RM2	Seals, Bearings, and 2-99% Arc Motors
TS1401-RM3	Seals, Bearings, and 2-35% Arc Motors
TS1401-RM4	Seals, Bearings, and 2-50% Arc Motors
TS1401-TK1	Seal and O-Ring Kit

Tune Up Kit Part Number	Description
<b>TS700</b>	
TS700-RM1	Bearing and O-Ring Kit (includes TS700-TK1)
TS700-TK1	O-Ring Kit

# Versatile Starting Performance

## Barring Motors



**For engine displacement of:**  
Diesel—up to 30,500 CID  
(500 liters) Carbureted—up  
to 61,000 CID (1000 liters)



## Features/Benefits

- Reversible vane air motor for precise control
- Rugged design provides maximum durability and dependability
- Pendant control enables safer one-person operation
- B006 for diesel engines with displacements up to 100 liters and gas engines up to 200 liters
- T480 for diesel engines with displacements up to 500 liters and gas engines up to 1000 liters
- Integral disc brake on T480 is always engaged when motor is not in operation to ensure safer, easier engine adjustments

## Versatile

- Available in two sizes
- Turns clockwise and counterclockwise at full power
- Can be used as a portable service tool or be permanently mounted to the engine
- Uses standard motor and pinion components
- Adjustable mounting flange allows multiple orientations



# Barring Motors

## Performance Information

Model	Flange	Weight lb (kg)	Max Pressure (motor inlet) psi (bar)	Breakaway Torque ft-lb (Nm)	Speed at Max Power rpm	Description
<b>B006</b>						
B006PVR374-01**	01	19 (9)	90 (6)	152 (207)	23	Barring Motor Only
B006PVR374-03**	03	19 (9)	90 (6)	152 (207)	23	Barring Motor Only
B006PVR374-01-***P	01	25 (11)	90 (6)	152 (207)	23	Barring Motor with Pendant Control
B006PVR374-03-***P	03	25 (11)	90 (6)	152 (207)	23	Barring Motor with Pendant Control

\*\*Pinion configurations: 15, 29, 31, 77, 79, 85, 94, 893, 895, 942. Additional flange and pinion configurations available upon request.

<b>T480 : Includes integral brake</b>						
T480PVRP-03**	03	58 (26)	90 (6)	322 (438)	65	Barring Motor Only
T480PVRP-03-***P	03	58 (26)	90 (6)	322 (438)	65	Barring Motor with Pendant Control

\*\*Pinion configurations: 25, 29, 31, 83, 85, 87, 94, 893, 895, 942. Additional flange and pinion configurations available upon request.

## Parts and Accessories

Part #	Description
PB006-15K	B006 Pendant Control & 2 Hoses (15'/4.6m each)
PB006-30K	B006 Pendant Control & 2 Hoses (30'/9m each)
43551-2	Muffler for B006
PT480-15K	T480 Pendant Control & 3 Hoses (15'/4.6m each)
PT480-30K	T480 Pendant Control & 3 Hoses (30'/9m each)
3BM-A674	Muffler for T480



A B006PVR374-03-31P barring motor using pendant control, slow turning a Caterpillar 3408 engine.

# Start with the Best

## Accessories

### Accessories Index By Description

Accessory Description	Part #	Page #
<b>Relay Valves</b>		<b>48-49</b>
	SRV100	
	SRV125	
	SRV125T	
	SRV125F	
	SRV150	
	SRV150SS	
<i>Relay Valve Tune Up Kit</i>	SRV150-TK3	
<b>Solenoid Control Valves</b>		<b>50-51</b>
	150BMP-1051B	
	150BMP-2451B	
	150BMP-6451B	
	150BMP-A1051B	
<i>Angle Mounting Bracket</i>	150BMP-B2451	
	ST400-A339M	
	ST400-C339	
<i>ST400 Repair Kit</i>	ST400-K619	
<b>Push Button Control Valves</b>		<b>52</b>
	SMB-618	
	SMB-G618	
	SMB-619	
<i>White Push Button Replacement</i> <i>Black Push Button Replacement</i>	SMB-620	

Accessory Description	Part #	Page #
<b>Air Strainers</b>		<b>53</b>
	ST900-267/100-HP	
	ST900-267/150-HP	
	ST900-267/200-HP	
<b>Mufflers</b>		<b>54</b>
	3BM-WM07	
	3BM-A674	
	150BM-A674	
	SS350-A674	
	ST500-674	
	SS800-A674	
<b>In-Line Lubricators</b>		<b>55</b>
	NL-8-8	
	NL-24-8	
<b>Regulators</b>		<b>56</b>
	NR-24-8	
<i>NR-24-8 Tune Up Kit</i>	NR24-TK1	

# Accessories

## Relay Valves

Ingersoll Rand relay valves provide immediate response to assure air starter disengagement and prevent damage to the pinion or flywheel ring gear. The aluminum die cast housing resists abrasion and corrosion while the stainless steel piston return spring will not rust from moisture in the air line.



SRV150



SRV150SS



SRV125F-P

### Specifications

- Maximum Operating Pressure = 225 psi (15.5 bar)
- Operating Temperature Range = -20 to 250°F (-29 to 121°C)
- Flow/Pressure Drop  $C_v = 37$

### Relay Valves

Part Number	NPT Size Inlet - Outlet	Weight lb (kg)	Description
SRV100	1" - 1"	3.10 (1.41)	3BMG, 5BMG, SS175G Relay Valve
SRV125	1-1/4" - 1 1/4"	2.90 (1.32)	150BM, SS350G, 150T Relay Valve
SRV125T	1-1/4" - 1 1/4"	2.90 (1.32)	150BM, SS350G, 150T Relay Valve for Transportation
SRV150	1 1/2" - 1 1/2"	2.70 (1.22)	SS800, ST700, ST900, ST600 Relay Valve
SRV150SS	1 1/2" - 1 1/2"	7.15 (3.24)	SS800, ST700, ST900 Relay Valve for Natural Gas Use
SRV125F-P	1-1/4" Flanged	7.40 (3.36)	150T/150BM 150T/150BM Flange Mount Relay Valve

### Inlet Pressure vs. Pilot Pressure to Open

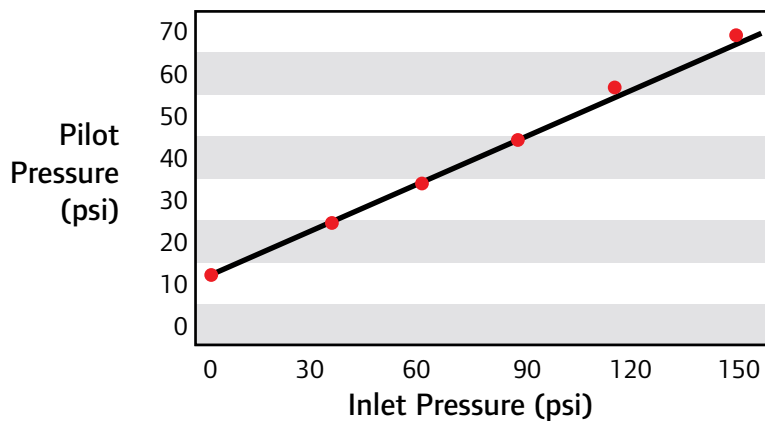



# Accessories

## Dimensions

**Note:** All dimensions shown are for reference only. Specifications subject to change without notice.

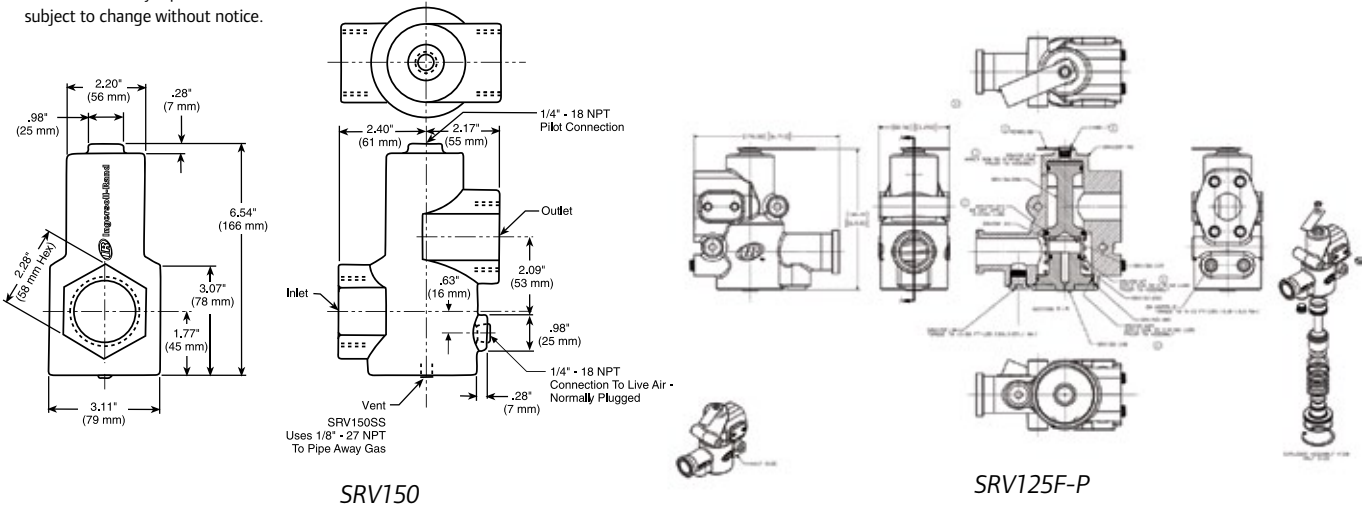

## Genuine Ingersoll Rand Replacement Kits

Tune Up Kit Part Number	Description
SRV150-TK3	For use with SRV100, SRV125, SRV125T, SRV150, and SRV150SS Relay Valves

## Parts

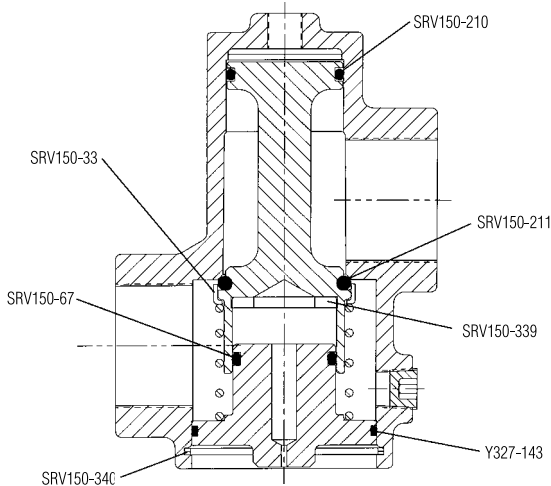

Cross-Section of SRV150-TK3 Part Location



SRV-TK3 Parts

## Solenoid Control Valves

These DC electrically actuated valves are designed for pilot operation of the Ingersoll Rand relay valve and are approved for applications affected by the U.S. Department of Transportation safety codes.

### Specifications

- Valve Type: Three-way normally closed  $C_v$  Factor: 0.21
- Power Consumption: 25 watts
- Operating Pressure Range: 0 to 300 psig (0 to 20.7 bar)
- Proof Pressure: 375 psig (25.9 bar)
- Burst Pressure: 1250 psig (86.2 bar)
- Media: Air, Inert gases, water, light oils
- Media Temperature: -4 to 392°F (-20° to 200°C)
- Ambient Temperature: -4 to 248°F (-20° to 120°C)
- Seal Material: Viton



150BMP-2451B

### 150BMP Solenoid Control Valves

Part Number	Thread Size Inlet – Outlet	Voltage (DC)	Weight lb (kg)	Description
150BMP-1051B*	¼" – ¼"	12 volt	1.95 (.88)	24" (61 cm) Long Wire Leads
150BMP-2451B*	¼" – ¼"	24 volt	1.95 (.88)	24" (61 cm) Long Wire Leads
150BMP-6451*	¼" – ¼"	64 volt	1.95 (.88)	24" (61 cm) Long Wire Leads
150BMP-A1051C*	¼" – ¼"	12 volt	1.95 (.88)	Pioneer Connector Lead

\* Can be mounted on 150BMP-B2451 elbow bracket.

### Dimensions

#### Solenoid Control Valve & Bracket

#### 150BMP-B2451 Mounting Bracket

Weight: .39 lbs (.17 kg)

**Note:** All dimensions shown are for reference only. Specifications subject to change without notice.

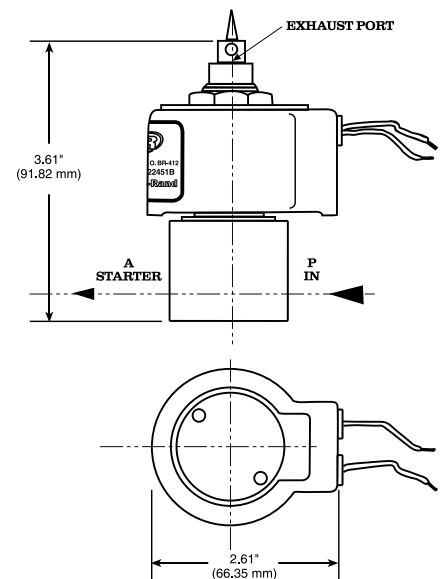
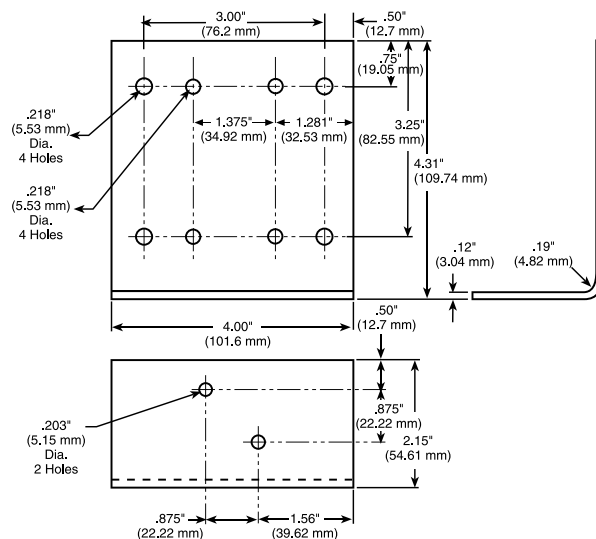

# Accessories

## Specifications

- Rated Operating Pressure: 150 psig
- Rated Operating Voltage: 12-24 VDC
- Rated Current Draw: 750 mA

## ST400 Solenoid Control Valves

Part Number	Inlet – Outlet	Weight lb (kg)	Description
ST400-A339M	1" – 1" Flange Style	4.5 (2.04)	Manual Control Valve; must be coupled to Solenoid or Push Button Valve
ST400-C339	1" – 1" Flange Style	2.96 (1.34)	Relay Valve with Top Mounted Solenoid Valve
ST400-K619	N/A	.30 (.13)	ST400-A339M Repair Kit

## Dimensions

### ST400-A339M

**Note:** All dimensions shown are for reference only. Specifications subject to change without notice.

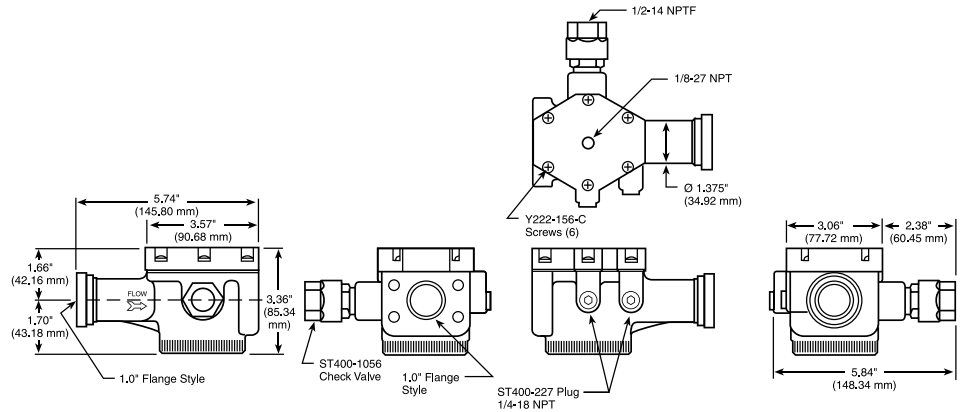

## Dimensions

### ST400-C339

**Note:** All dimensions shown are for reference only. Specifications subject to change without notice.

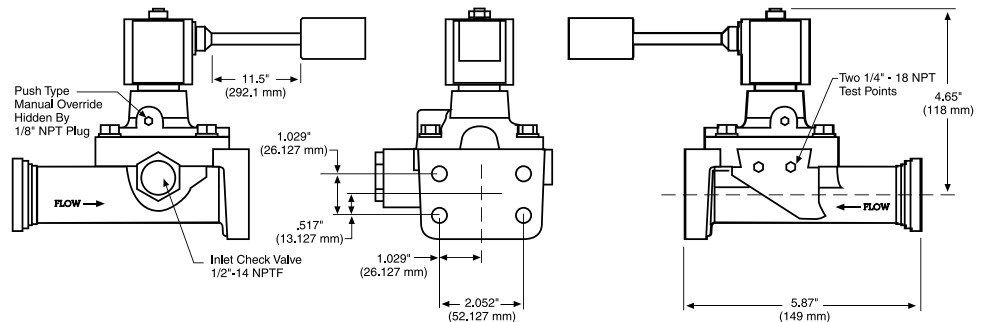

## Push Button Control Valves

The Ingersoll Rand manually actuated push button control valve is designed for pilot operation of the relay valve. Simple and reliable, this valve readily mounts in a 7/8" diameter hole on dashboards or control panels. The chrome-plated SMB-G618 valve is available for use in marine, offshore and natural gas applications, while the brass bodies SMB-618 valve is suitable for air applications only.

### Specifications

- Operating Temperature Range: -40 to 200°F (-40 to 93.3°C)
- Maximum Operating Pressure: 225 psi (15.5 bar)



## Push Button Control Valves

Part Number	NPT Size Inlet – Outlet	Weight lb (kg)	Description
SMB-618	1/8" – 1/8"	.47 (.21)	Air-approved Push Button Valve
SMB-G618	1/8" – 1/8"	.48 (.21)	Gas-approved Push Button Valve

## Ingersoll Rand Replacement Parts

Part Number	NPT Size Inlet – Outlet	Weight lb (kg)	Description
SMB-619	.25" – 28 UNF	.05 (.02)	White Push Button
SMB-620	.25" – 28 UNF	.05 (.02)	Black Push Button

## Dimensions

### SMB-G618

**Note:** All dimensions shown are for reference only. Specifications subject to change without notice.

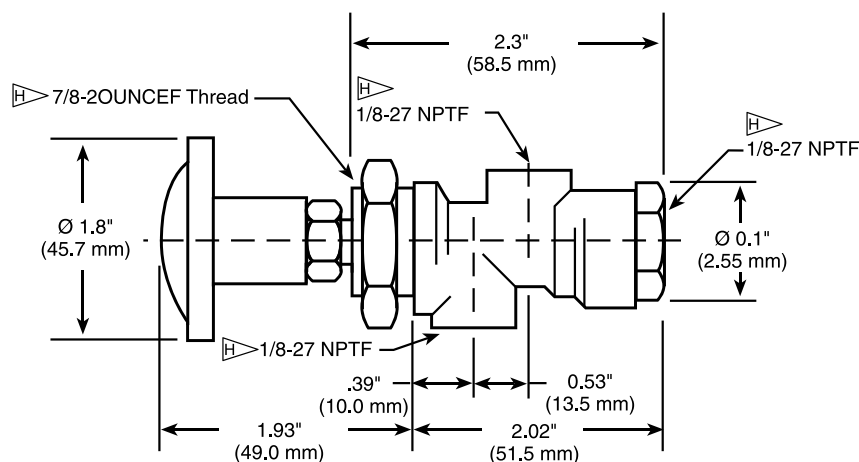

# Accessories

## Air Strainers

Ingersoll Rand strainers are used in the air line to assure long starter life where air or gas is contaminated. The ST900 strainer screens the starter air utilizing a 300-mesh element reinforced on two sides by a 20-mesh internal stainless steel screen to ensure air integrity. The ST1000 strainers have stainless steel bodies and utilize 40-mesh stainless steel screens.



ST900-267H/100  
ST900-267H/150  
ST900-267H/200  
Strainer Housing



ST900-266/100-HP  
ST900-266/150-HP  
ST900-266/200-HP  
Strainer Element

### Maximum Working Pressure:

Saturated Steam	Water, Oil, Gas	Compressed Air
250 psi @ 400°F	400 psi @ 150°F	500 psi @ 150°F
15.5 bar @ 204°C	27.6 bar @ 66°C	34.4 bar @ 66°C

### ST900 Air Strainers (Housing + Strainer Element)

Part Number	Thread Size Inlet - Outlet (NPT)	Weight lb (kg)	Strainer Element Replacement Part #
ST900-267/100-HP	1" - 1"	3.00 (1.36)	ST900-266/100-HP
ST900-266/150-HP	1-1/2" - 1-1/2"	2.66 (1.21)	ST900-266/150-HP
ST900-266/200-HP	2" - 2"	3.92 (1.78)	ST900-266/200-HP

### Dimensions

Part Number	Dim. A in. (mm)	Dim. B in. (mm)	Dim. C in. (mm)
ST900-267/100-HP	4.00 (101.4)	3.25 (82.6)	2.62 (66.5)
ST900-267/150-HP	4.72 (120.0)	5.00 (127.0)	2.99 (76.0)
ST900-266/200-HP	5.51 (140.0)	6.125 (155.6)	3.54 (89.9)

**Note:**  
All dimensions shown are for reference only. Specifications subject to change without notice.

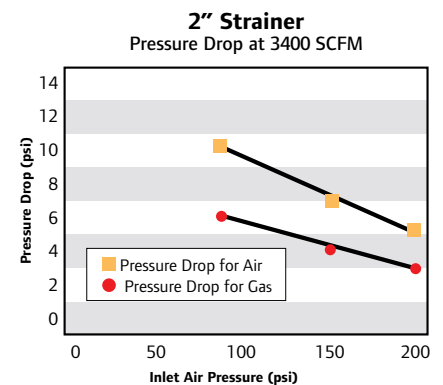
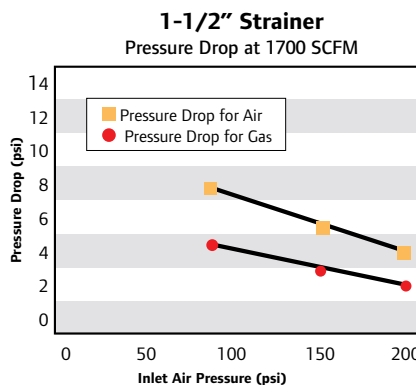
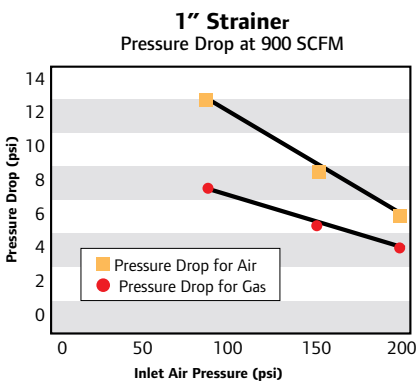
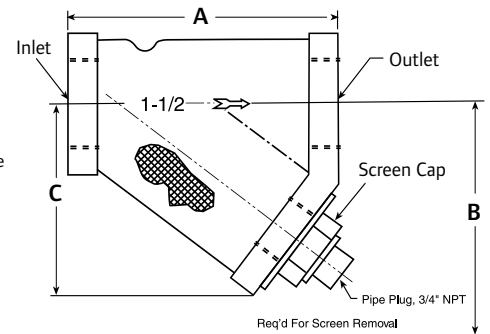

# Accessories

## Mufflers

Ingersoll Rand mufflers are designed to effectively limit starting noise levels.

### Specifications

- Low back pressure provides minimal power loss for full starter power
- Effective sound attenuation for low noise level
- Non-freezing for reliable operation
- Self-cleaning to eliminate clogging and ensure longer life while reducing maintenance time
- Capable of direct or remote mounting for flexibility of application

### Dimensions

**Note:** All dimensions shown are for reference only. Specifications subject to change without notice.

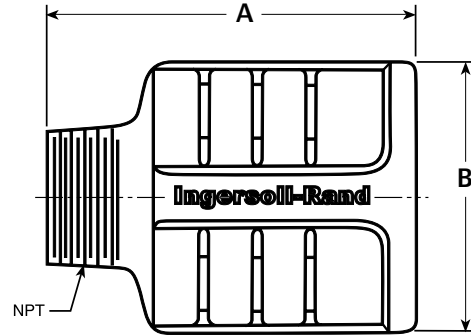

## Mufflers

Part Number	NPT Size	Dim. A in. (mm)	Dim. B in. (mm)	Weight lb (kg)	For Model Series
3BM-WM07	3/4"	7.18 (182.37)	2.22 (56.37)	.83 (0.38)	3BM, 5BM (Older Housing)
3BM-A674	1"	8.66 (219.96)	3.85 (97.79)	1.19 (0.54)	3BM, 5BM (New Housing)
150BM-A674	1-1/4"	4.21 (106.9)	3.34 (84.8)	1.50 (0.68)	150BM, SS175
SS350-A674	1-1/2"	4.56 (115.8)	3.31 (84.1)	1.13 (0.50)	SS350
150T-312	2"	5.50 (139.7)	2.75 (69.85)	1.85 (0.84)	150T, ST500
SS800-A674	2-1/2"	6.66 (169.21)	4.75 (120.77)	3.35 (1.52)	SS800



3BM-WM07



3BM-A674



150BM-A674



SS350-A674



150T-312



SS800-A674

## In-Line Lubricators

### Specifications

- Reservoir: 1/2 Pint Metal
- Maximum Operating Temperature = 175°F (79°C)
- Maximum Operating Pressure = 250 psi (17.2 bar)
- C = 26
- Media: Air, clean natural gas (see circular letter A-1077)
- Recommended Operating Flow Range at 100 psig (6.9 bar): 160 to 600 scfm (78 to 283 dm<sup>3</sup>/s)
- Recommended Lubricants: This lubricator will perform satisfactorily using misting type oils rated 150 to 200 SSU (Saybolt seconds) @ 110°F (38°C)
- Material Construction: Body = Aluminum — Reservoir = Steel  
Sight-Feed Dome = Pyrex & Aluminum  
Elastomers = Neoprene & Buna-N

### Installation

- Air line piping should be same size as lubricator ports.
- Install lubricator vertically (sight-feed dome up) in air line downstream of filter and regulator as near as possible to the device being served. This lubricator may be installed upstream or downstream of directional control valves.
- Connect piping to proper ports using pipe thread sealant on male threads only. Do not allow sealant to enter interior of lubricator. Air flow must be in direction of arrow on side of body.
- Remove fill plug and fill reservoir with a good quality lubricant to 3/4" below bottom of threads on dipstick. Do not overfill.

### Warning

These units must not be used where pressure or temperature may exceed maximum rated operating conditions. See specifications.

In lubrication applications, some oil mist may escape from the point of use into the surrounding atmosphere. Users are referred to OSHA safety and health standards for limiting oil mist contamination and utilization of protecting equipment.



NL-8-8



NL-24-8

### Adjustment

- Adjust drip rate only when there is a constant rate of flow through the lubricator.
- Determine the average rate of air flow (scfm) through the lubricator, then adjust the needle valve using a 3/32" allen wrench to obtain the recommended drip rate (Drops/min). Turn needle valve counterclockwise to increase and clockwise to decrease the drip rate.
- Monitor the device being lubricated for a few days following initial adjustment. Readjust the drip rate if the oil delivery at the device appears either excessive or low.

### In-Line Lubricators

Part Number	Port Thread Size NPT Inlet – Outlet	Weight lb (kg)
NL-8-8	1/2" – 1/2"	1.70 (.77)
NL-24-8	1-1/2" – 1-1/2"	2.70 (1.22)
NL24-TK1	N/A	.05 (.02)

NL-8-8

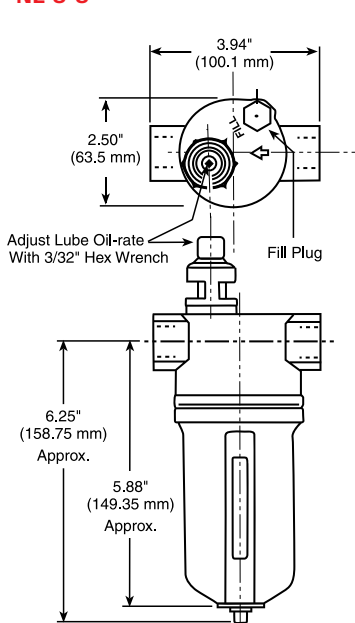

NL-24-8

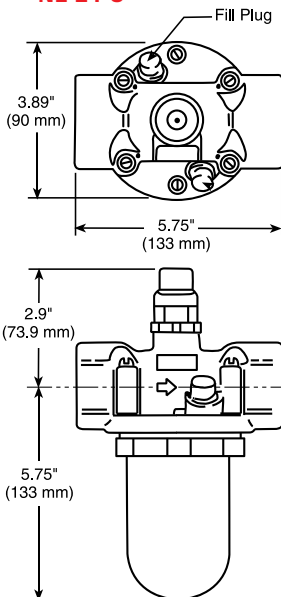

### Recommended Drip Rate

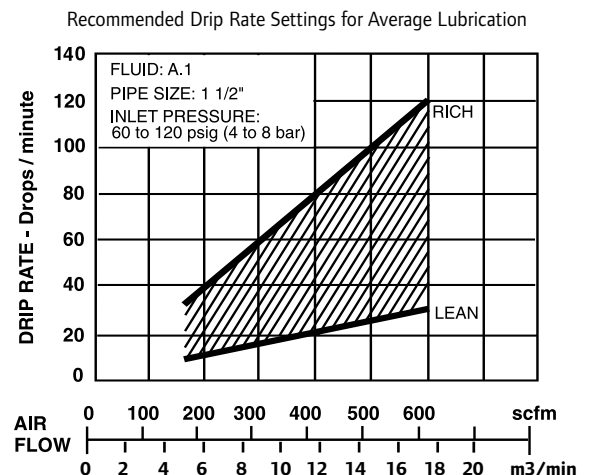

# Accessories

## Regulators

### Rated Operating Conditions

- Inlet Pressure: 10 to 450 psig (0.7 to 31 bar)
- Maximum Outlet Pressure: 250 psig (17.2 bar)
- Temperature: 0° to 175°F (-18° to 79°C)  
- With dewpoint less than air temperature below 35°F (2°C)
- Air Consumption: 2200 scfm @ 150 psi

### Specifications

- Fluid: Compressed Air
- Type: Relieving
- Ports: Main: 1-1/2" or 2" NPT  
Gauge: 1/4" NPT  
Exhaust (relieving models only): 3/4" NPT
- Outlet Pressure Adjustment Range:  
10 to 250 psig (0.7 to 17.2 bar)
- Threads: Use SMB-441 sealant on threads of air line fittings. Apply sealant evenly to threads only. Excessive sealant may interfere with valve operation.



NR-24-8  
Pilot Operated  
Regulator with  
Integral Pilot

Outlet pressure adjustment ranges are not minimum or maximum outlet pressure limits. Regulators can be adjusted to zero psig outlet pressure and, generally, to pressures in excess of those specified. The use of these regulators to control pressures outside of the specified ranges is not recommended.

### Dimensions

NR-24-8

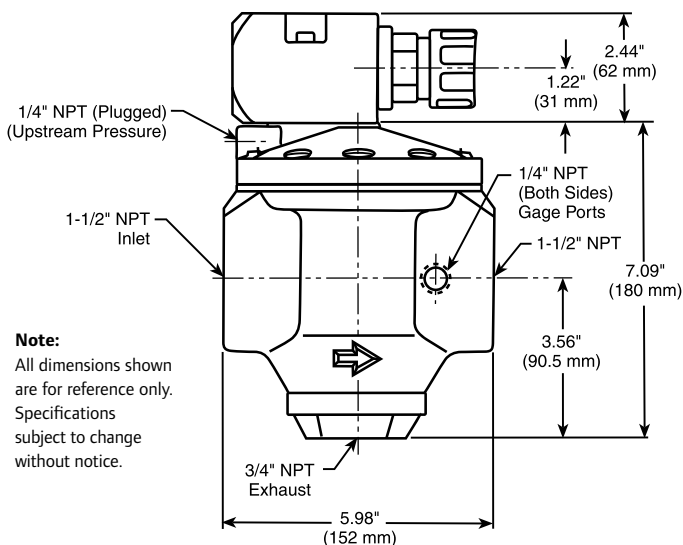
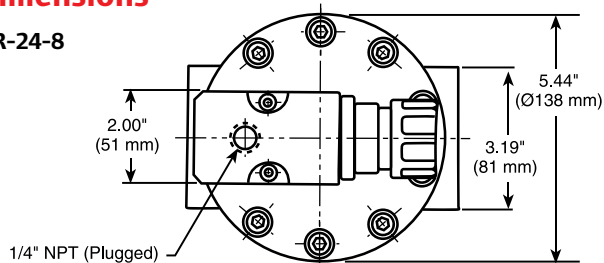

**Note:**  
All dimensions shown are for reference only. Specifications subject to change without notice.

## Regulators

Part Number	Description
NR-24-8	Pilot Operated Regulator with Integral Pilot (1-1/2" NPT)
NR-24-8-2	Pilot Operated Regulator with Integral Pilot (2" NPT)
NR24-TK1	NR-24-8 Tune Up Kit



# At Your Service

## Installation Configurations

Series/Installation Configuration	Page #
150/ST500 Stationary (Gas)	58
ST400	58
ST700/ST900/ST1000 Inertia	59
ST600/ST700/ST900/ST1000 Stationary	59
ST600/ST700/ST900/ST1000 Multiple Starter	60
150BMP/SS100	61
SS350/150MPE Stationary	61
SS350/150BMPE Vehicular	62
150BMG (Gas) Stationary	62
SS810 Stationary	63
SS815/SS825/SS850 Stationary	63



# Installation Configurations

## 150 & ST500 Stationary - Gas

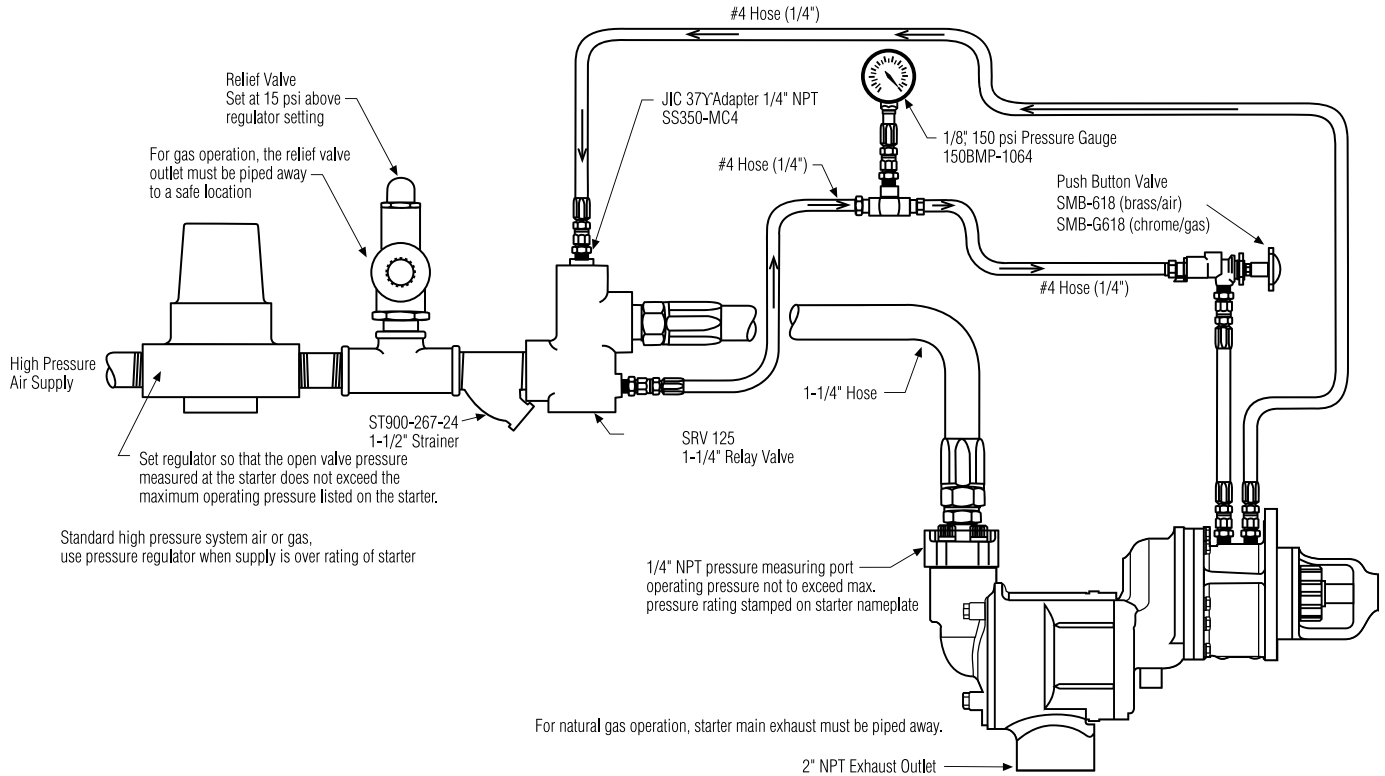

## ST400 Installation

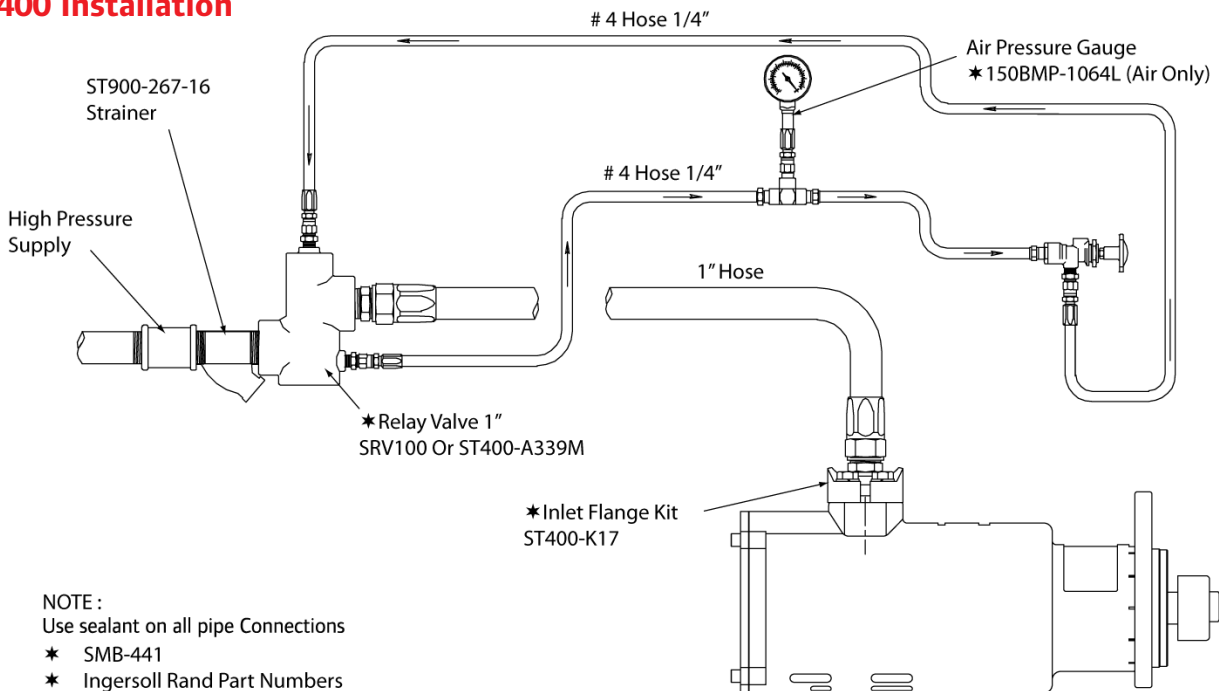

# Installation Configurations

## ST700/ST900/ST1000 Inertia Installation

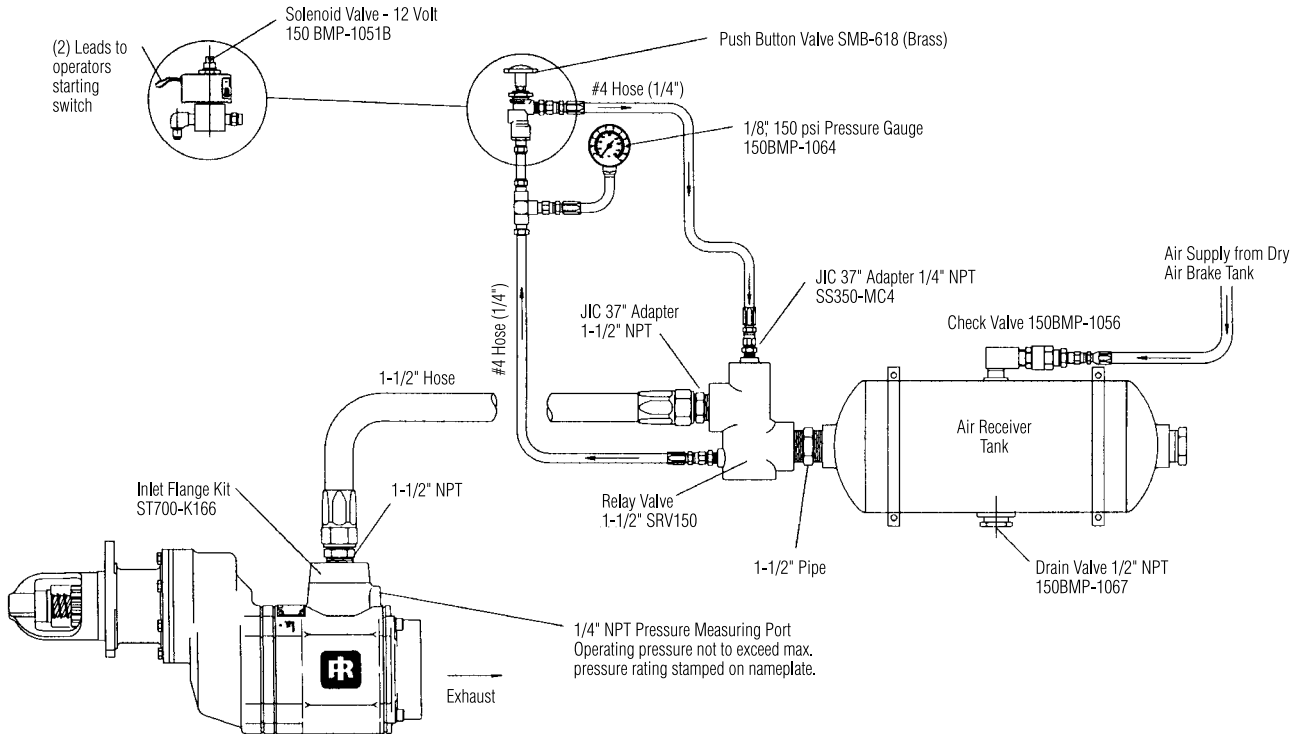

## ST600/ST700/ST900/ST1000 Typical Stationary Installation

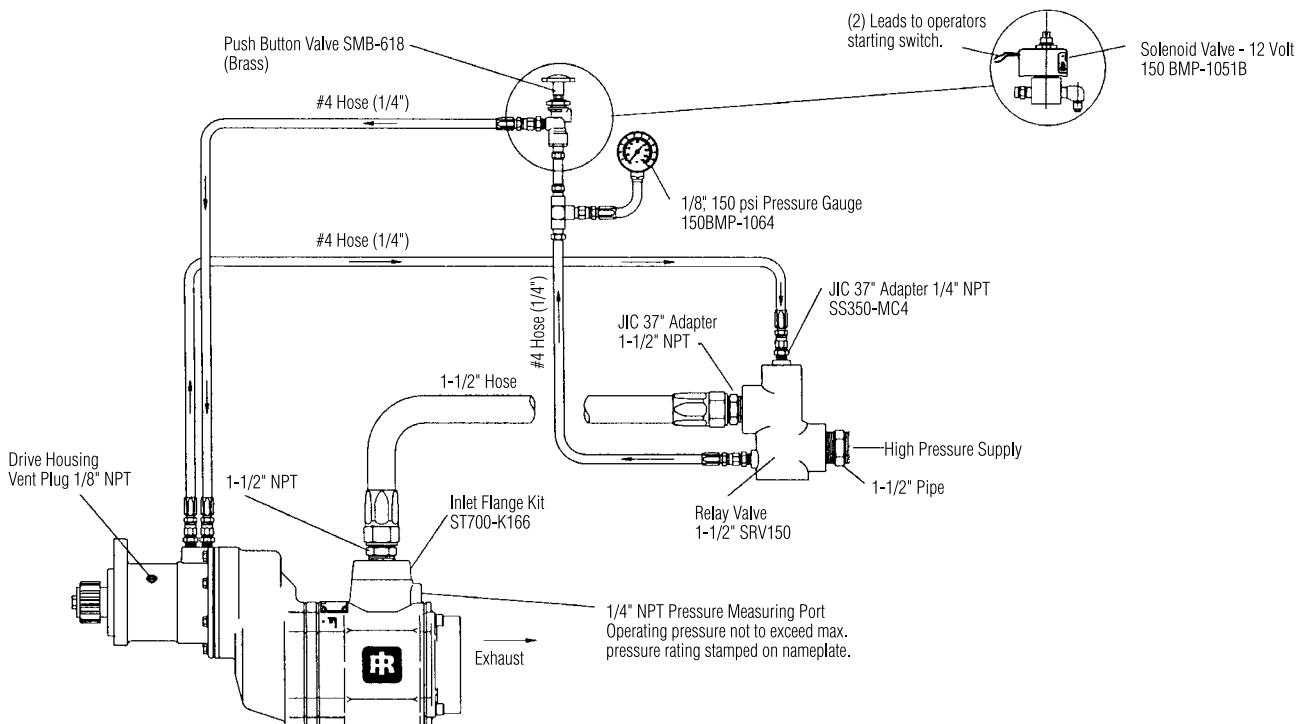

# Installation Configurations

## ST600/ST700/ST900/ST1000 Typical Multiple Starter Application Installation

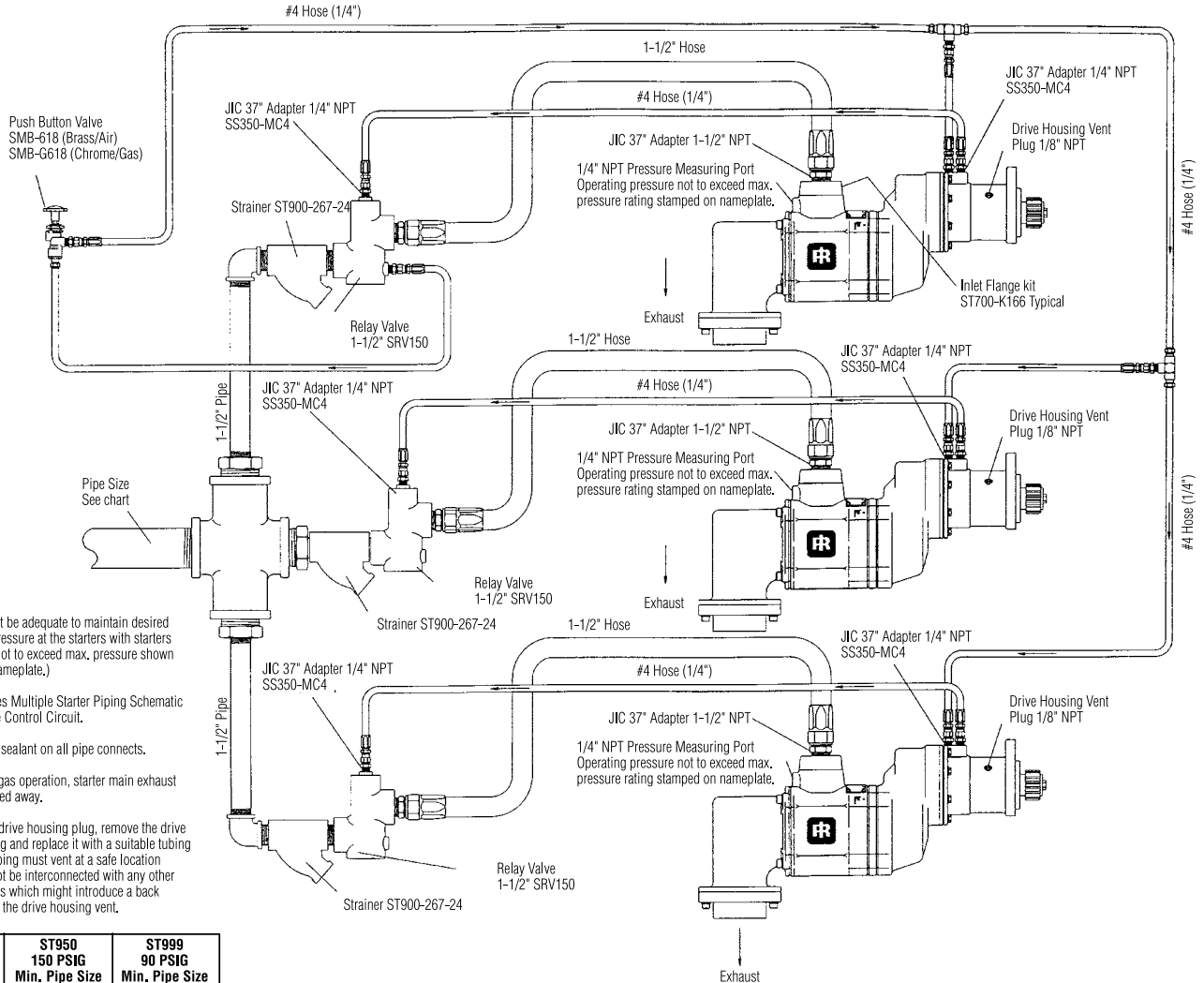

Supply must be adequate to maintain desired operating pressure at the starters with starters running. (Not to exceed max. pressure shown on starter nameplate.)

ST900 Series Multiple Starter Piping Schematic showing the Control Circuit.

NOTE: Use sealant on all pipe connects.

For natural gas operation, starter main exhaust must be piped away.

To pipe the drive housing plug, remove the drive housing plug and replace it with a suitable tubing line. The tubing must vent at a safe location and must not be interconnected with any other exhaust lines which might introduce a back pressure on the drive housing vent.

No. of Starters	ST950	ST999
	150 PSIG Min. Pipe Size	90 PSIG Min. Pipe Size
2	2-1/2"	3"
3	3"	3-1/2"
4	3-1/2"	4"
5	3-1/2"	4"

# Installation Configurations

## 150BMP and SS100 Typical Installations

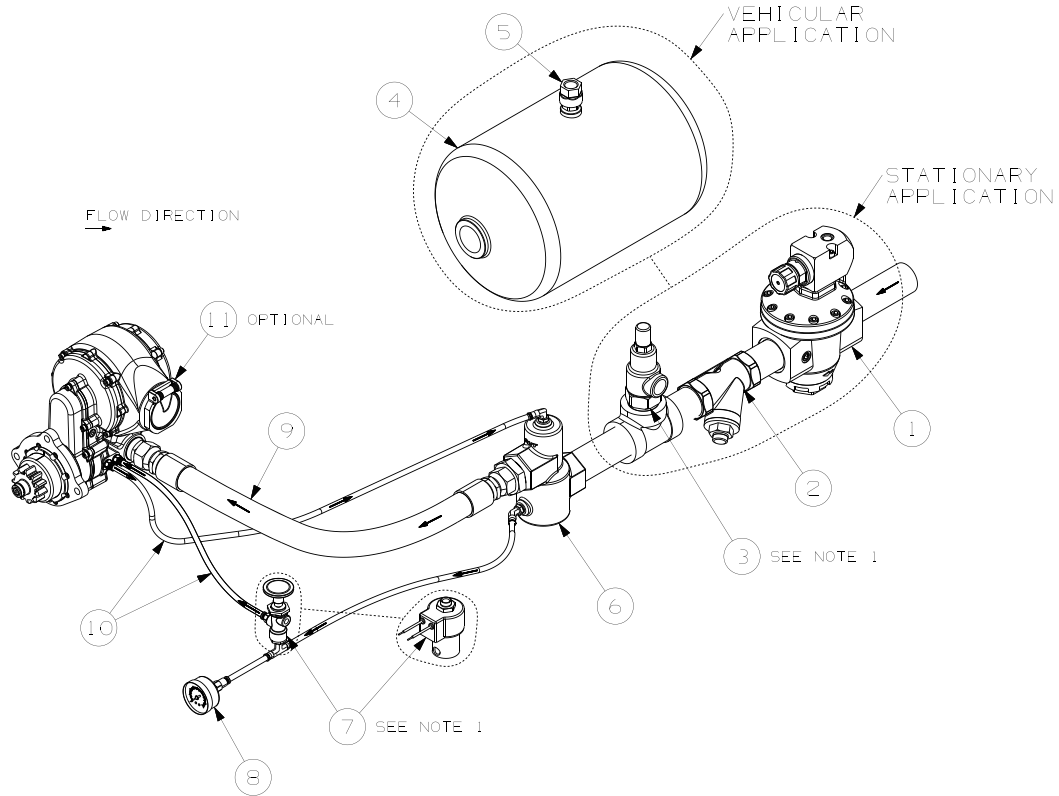

## SS350/150MPE Stationary Installation

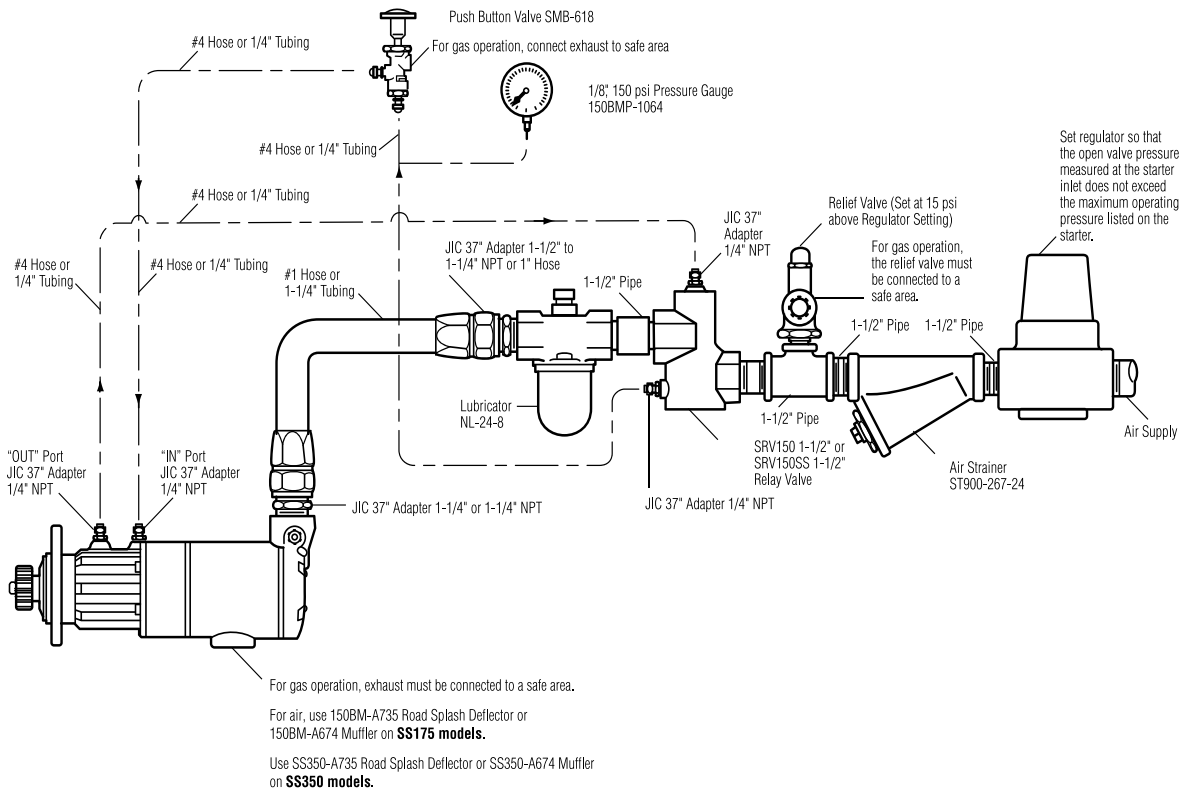

# Installation Configurations

## SS350/150BMPE Typical Vehicular Installation

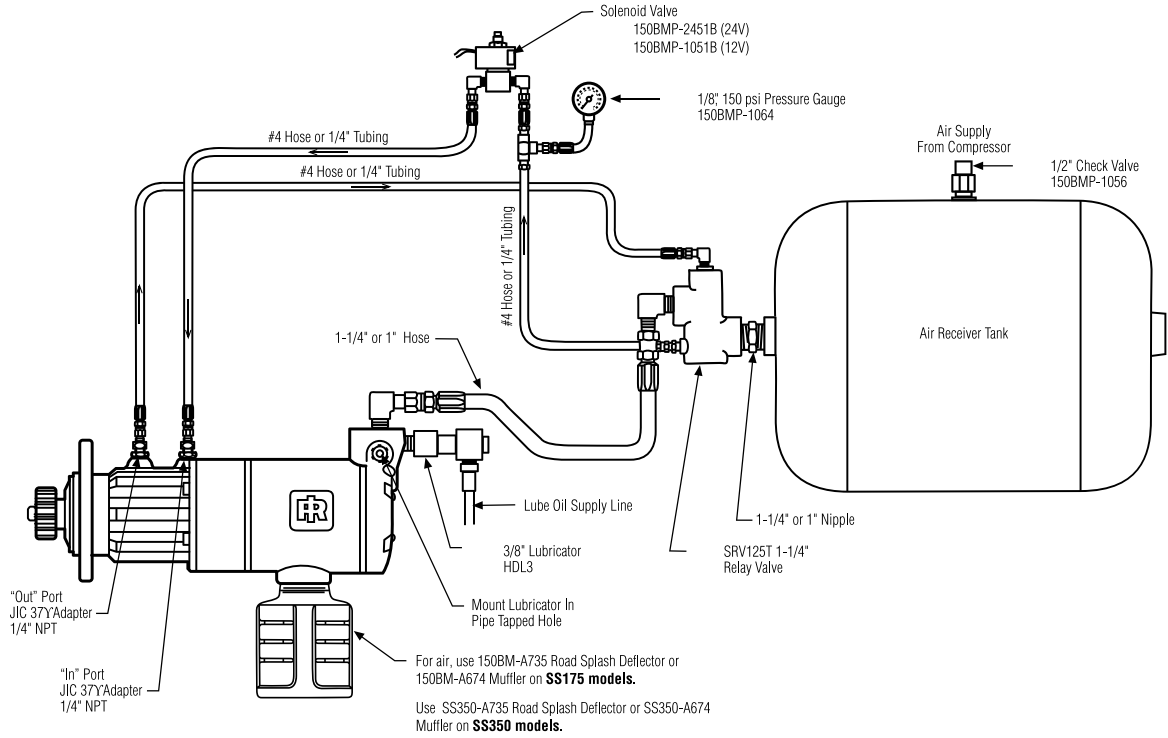

## 150BMG (Gas) Stationary Installation

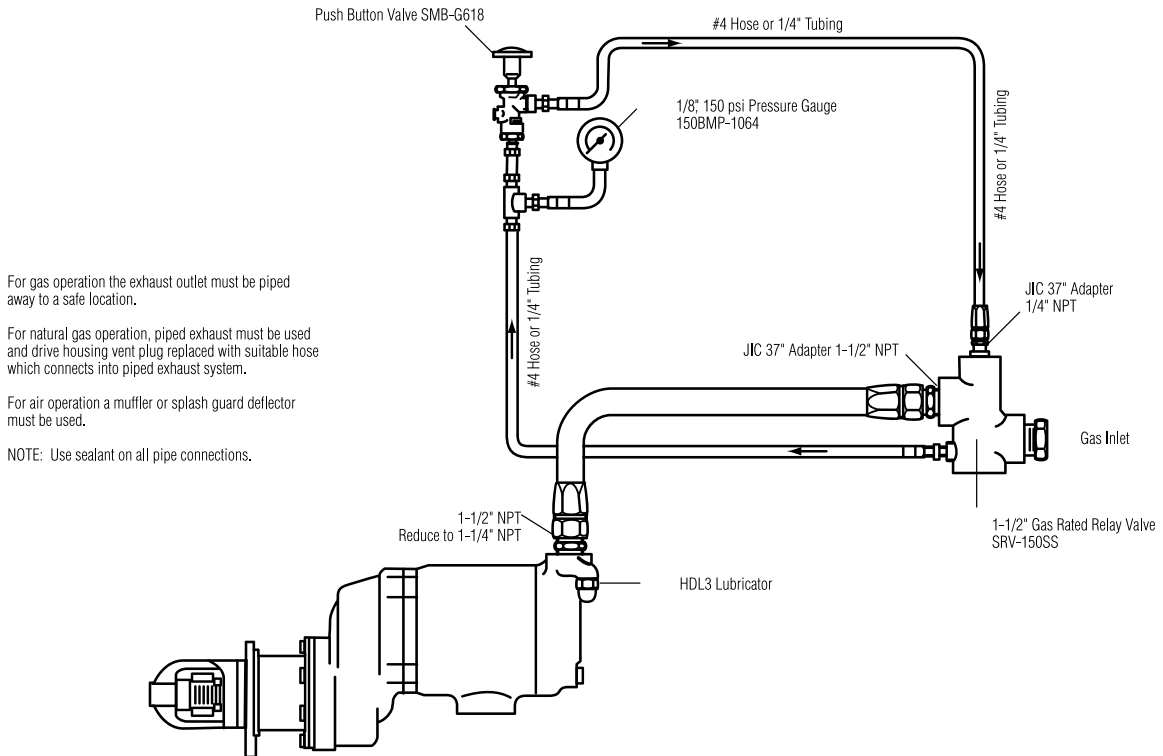

# Installation Configurations

## SS810 Typical Stationary Installation

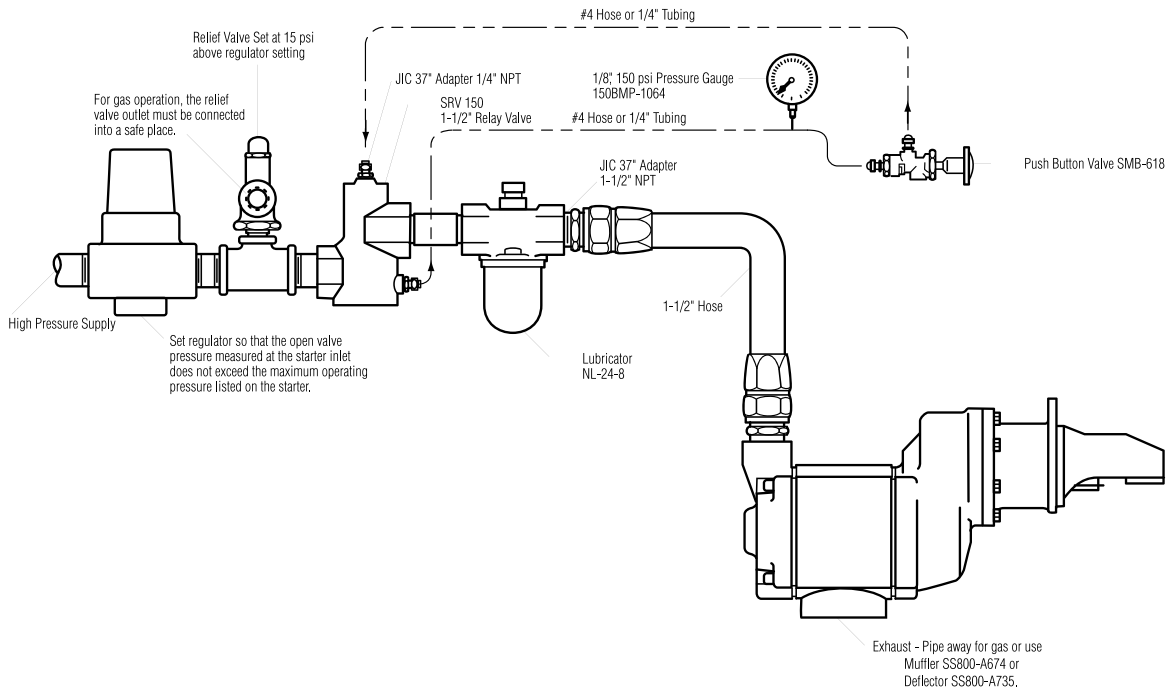

## SS815/SS825/SS850 Typical Stationary Installation

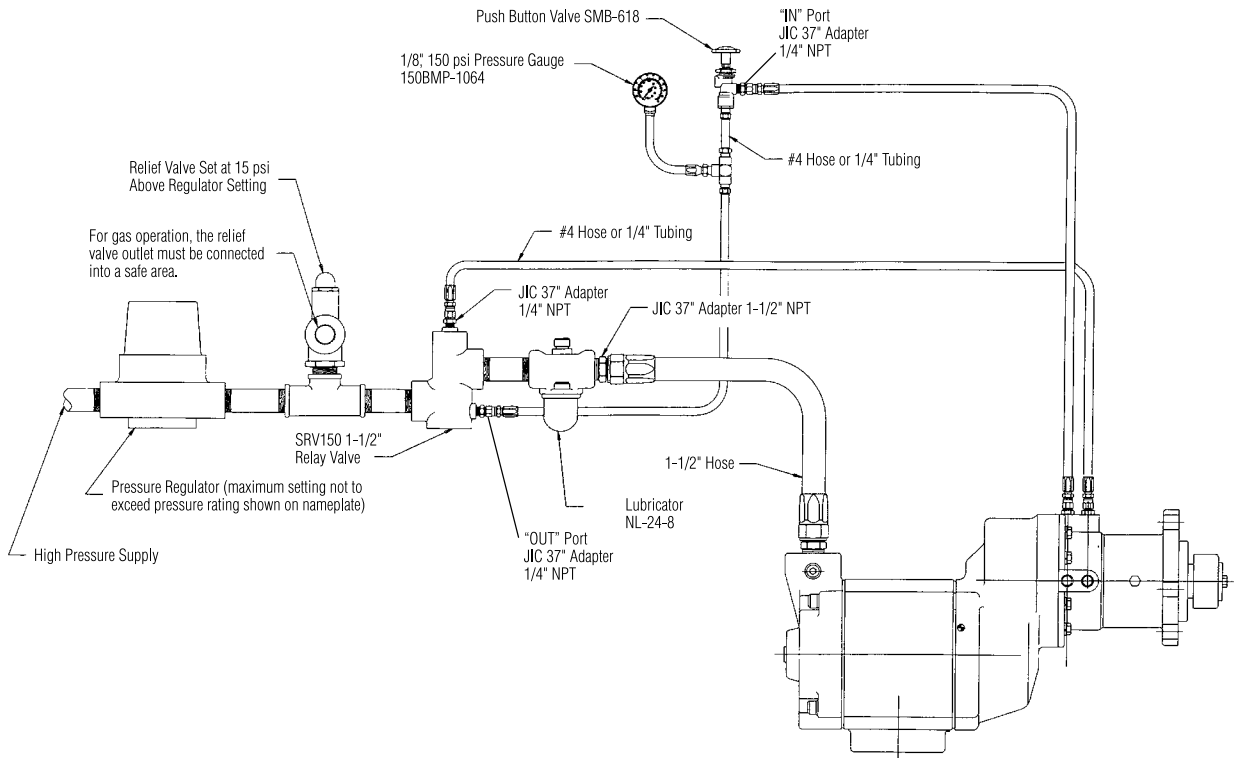



Ingersoll Rand (NYSE:IR) advances the quality of life by creating and sustaining safe, comfortable and efficient environments. Our people and our family of brands — including Club Car®, Ingersoll Rand®, Schlage®, Thermo King® and Trane® — work together to enhance the quality and comfort of air in homes and buildings; transport and protect food and perishables; secure homes and commercial properties; and increase industrial productivity and efficiency. Ingersoll Rand products range from complete compressed air systems, tools and pumps to material handling systems. The diverse and innovative products, services and solutions enhance our customers' energy efficiency, productivity and operations. We are a \$14 billion global business committed to a world of sustainable progress and enduring results.



[ingersollrandproducts.com](http://ingersollrandproducts.com)



Ingersoll Rand, IR and the IR logo are trademarks of Ingersoll Rand, its subsidiaries and/or affiliates.

Nothing contained on these pages is intended to extend any warranty or representation, expressed or implied, regarding the product described herein. Any such warranties or other terms and conditions of sale of product shall be in accordance with Ingersoll Rand's standard terms and conditions of sale for such products, which are available upon request.

Product improvement is a continuing goal at Ingersoll Rand. Designs and specifications are subject to change without notice or obligation.