



Ergonomic Handling Systems

TiD-extra
Industrial Technologies



Team up with our European Solutions Center to develop your projects

Offering full-service capabilities tailored to our customers' needs:

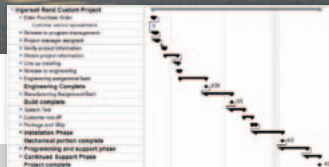

Engineering

- ▶ Feasibility study
- ▶ Concept design
- ▶ Simulation
- ▶ System design
- ▶ 2D and 3D CAD

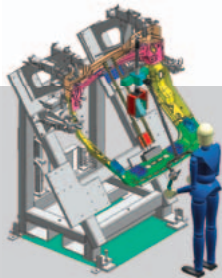

Project management

- ▶ Dedicated project manager
- ▶ Project planning
- ▶ Coordination
- ▶ Execution

Service

- ▶ Installation and start-up support
- ▶ Training
- ▶ Preventive maintenance
- ▶ Calibration and repair service
- ▶ Technical support

Providing turnkey, customized solutions that improve our customers' productivity and efficiency:

Custom Ergonomic Handling Systems



Custom Multi-Spindle Fastening Systems



Custom Solution Process

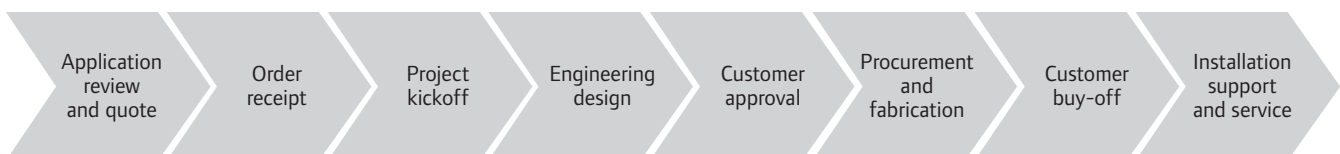

From RFQ → To Installation

Contents

The rising importance of ergonomics

Ergonomics (literally, the science of work) is the key to designing a better workplace, where tool, task and operator come together with a minimum of stress. A minimum of stress on the worker leads to a maximum level of quality production...

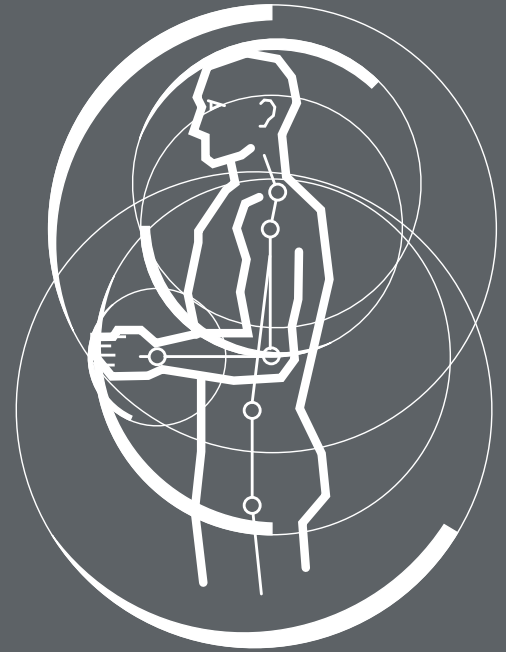

Since 1959, Ingersoll Rand has been at the forefront of developing ergonomic solutions for lifting, manipulating, and transferring loads by offering a complete line of products designed to maximize productivity while simultaneously minimizing operator fatigue and discomfort. No matter what your requirement, Ingersoll Rand offers the products for you to do your job effectively, efficiently, and above all, safely. By choosing Ingersoll Rand, you are receiving 50 years of innovation and product expertise that is unrivalled anywhere else.

Rail Systems

Page 6



Arm Systems

Page 30



Jib Cranes

Page 14



Handling Devices

Page 38



Balancers

Page 19



Selection Guide

Three building blocks to a complete ergonomic handling solution



OVERHEAD SUPPORTS

Ceiling-supported workstations crane and monorails (page 7)

- Capacities up to 1360 kg
- For use when there is limited floor space and adequate ceiling structure to support the load
- Capable of mounting parallel or perpendicular to overhead support steel
- Provides rectangular coverage for a single workstation, or an entire assembly line with multiple bridge cranes

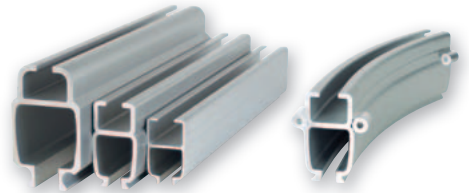
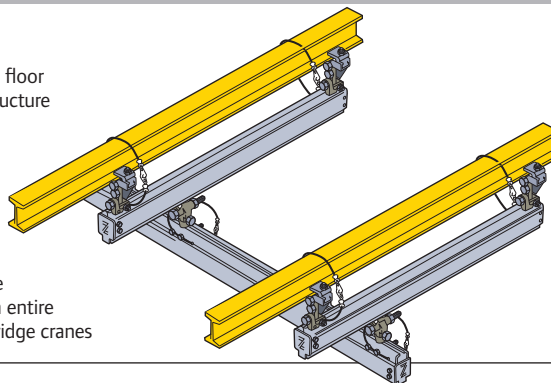

- Provides simple single-axis transfer
- Curved sections available for monorail systems



LIFTING / BALANCING DEVICES

Pneumatic balancers (page 20)



- Capacities up to 450 kg
- Allows user to move load via up / down controls then float mode allows for precision manual movement and placement of the load without having the “jogging” associated with air and electric hoists
- Energy savings — less air consumption than an air hoist
- Used in applications where precision spotting is necessary
- Offers up to 3 m travel

Intellift® balancer (page 24)



- Capacities up to 450 kg
- IntelLIFT® removes the need for up / down switches and allows for completely manual operation by sensing user force input and translating it to precise lifting / lowering
- Features float mode throughout entire range of motion
- Used in applications where:
 - Precision spotting is necessary
 - Hands-on control of load is required / beneficial
 - One hand operation is beneficial



HANDLING DEVICES

Hook (page 41)



- Used in applications where:
 - Simple pick and place
 - Straight transfer with no part manipulation
 - Hook access is readily available
 - Odd-shaped parts

Probe (page 40)



- Used in applications where:
 - Part is cylindrical with an accessible hole in the core
 - Straight transfer or manipulation of parts
 - Typical parts include rolls and machined parts



Trap (page 41)

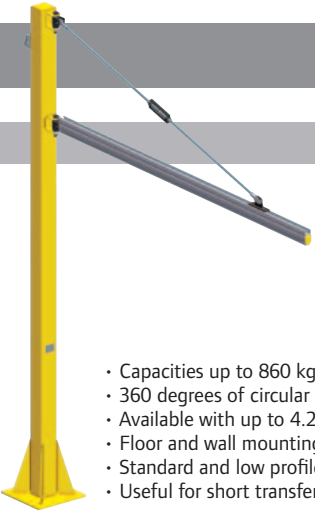

- Used in applications where:
 - Simple pick and place
 - Straight transfer with no part manipulation
 - Accessible grab locations on both sides of part



Jib cranes (page 15)

- Capacities up to 860 kg
- 360 degrees of circular coverage area
- Available with up to 4.25 m (3.65 m standard) boom underclearance
- Floor and wall mounting options
- Standard and low profile configurations
- Useful for short transfer applications less than 6m

Spring balancers (page 28)



- Capacities up to 180 kg
- Lifts ranging from 1.6 m to 3 m
- Used in applications where:
 - Loads travel a relatively short distance
 - One tool is used repeatedly in a limited area of motion, such as assembly stations
 - Single load balancing is required (weld guns, assembly fixtures, etc.)

Arms (page 31)



- Capacities up to 450 kg
- Great for reaching in, under, and around obstacles to precisely and effortlessly position loads
- Column or overhead mounting options
- Available in three styles: articulating, parallel link, and vertical mast
- Up to 3 m of horizontal reach

Torque tube (page 42)



- Capacities up to 68 kg
- Vertical travel range of up to 914 mm
- Rigidity of the system minimizes inertia when moving loads into place along a rail system
- Useful with lifting offset loads where the weight of the load is disproportionate to the center of gravity
- Provides torque reaction for fastening systems

Vacuum (page 38)

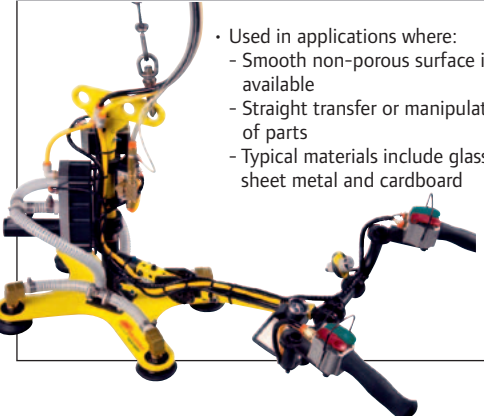

- Used in applications where:
 - Smooth non-porous surface is available
 - Straight transfer or manipulation of parts
 - Typical materials include glass, sheet metal and cardboard

Clam (page 39)

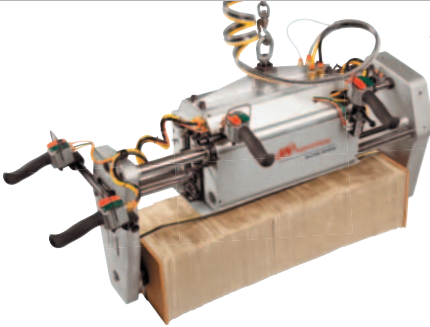

- Used in applications where:
 - Part is rigid with accessible clamping surfaces
 - Straight transfer or manipulation of parts
 - Typical parts include machined parts, bundles, fabricated metal parts

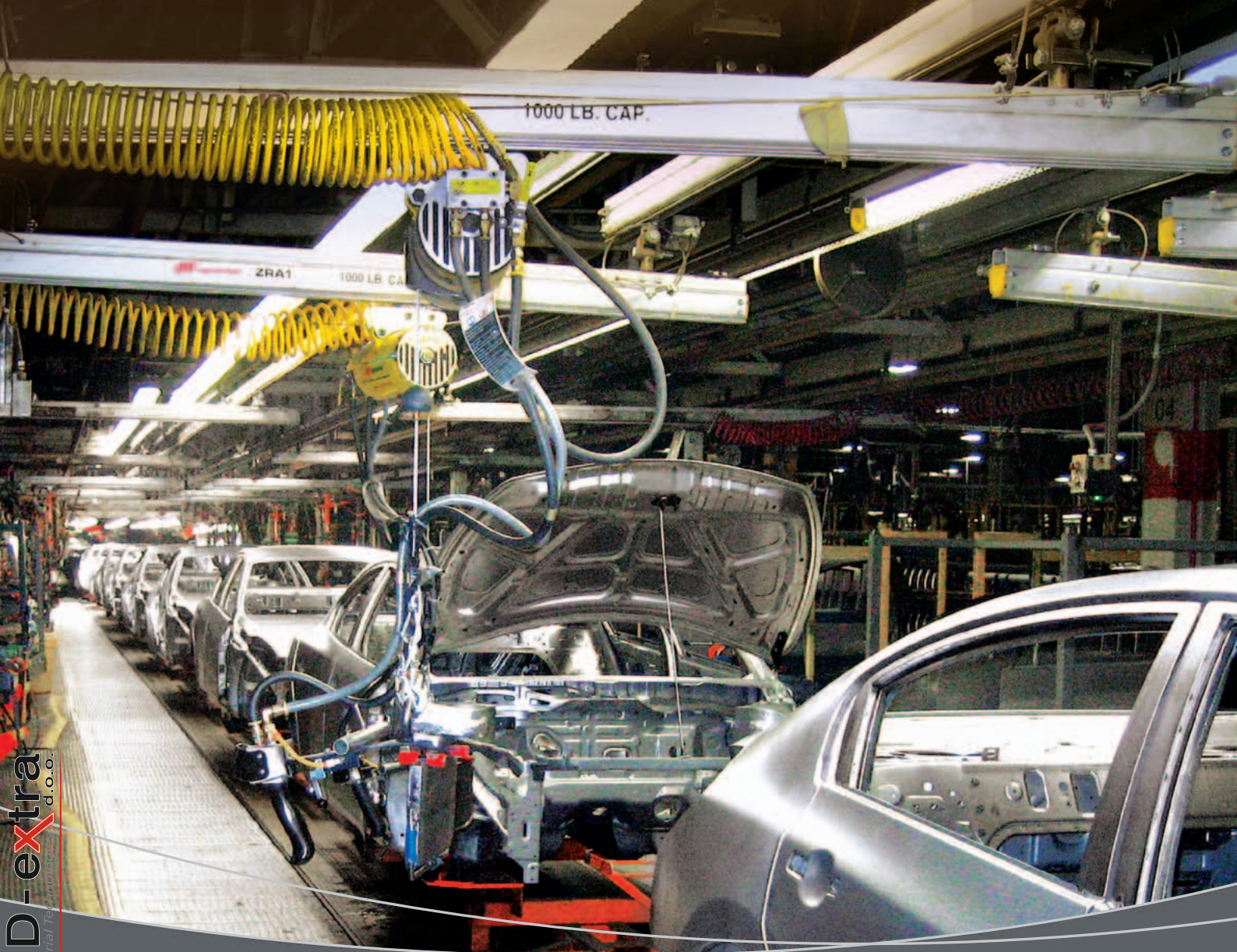

Rail Systems

The backbone of any ergonomic material handling system

Ingersoll Rand offers:

- ▶ Ceiling-supported workstation bridge cranes
- ▶ Monorails

Ceiling-supported workstations cranes

Ideal for high-volume production environments with limited floor space.

Capable of mounting parallel or perpendicular to overhead support steel.

Provide rectangular coverage for a single workstation, or an entire assembly line with multiple bridge cranes.

Capacities up to 1400 kg.



Safety first

Ingersoll Rand's primary and vital concern is safety.

Safety factor: all components are rated at a 5 to 1 safety factor based on meticulous tests performed at independent testing laboratories.

Deflection: Ingersoll Rand rail is designed to not exceed 1/450 of span, in accordance with ANSI B30.11 Monorail and Underhung Cranes.

Safety cables: we require the use of safety cables at all moving (hanger and end-truck) suspension points.

Redundant end stops: available for extra safety.

Load ratings: clearly marked on both sides of bridges rails.

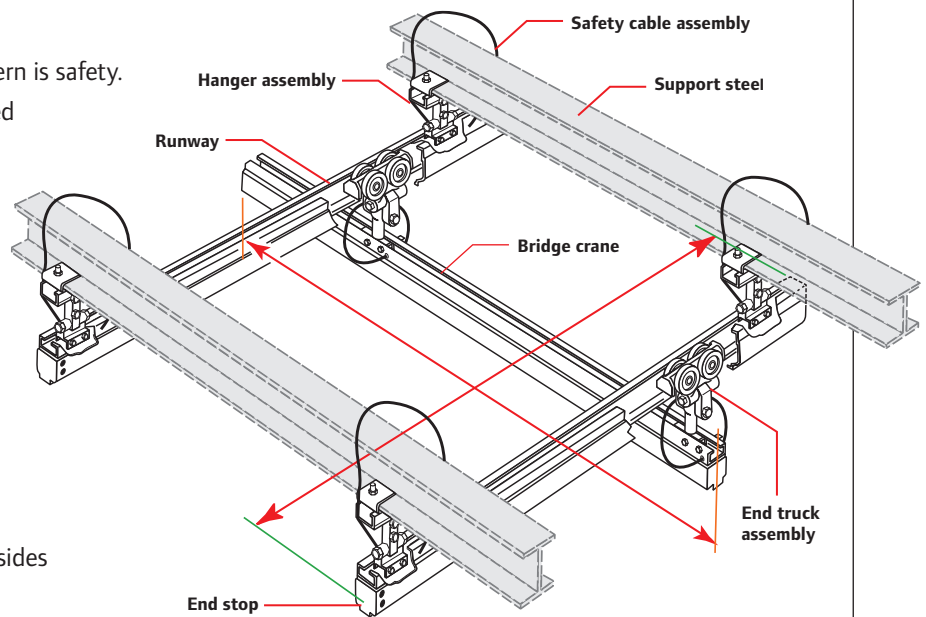

Facilitates quick, precision positioning

Thanks to the quality of the rolling surfaces, the guidance of the trolleys and the articulated suspensions, Ingersoll Rand systems allow you to move loads with a maximum starting force of 1.5 % of the total load (bridge plus load). Furthermore, the rolling effort required during displacement is less than 1 % – even if the load is pushed far away from the centre of the bridge (see sketches).

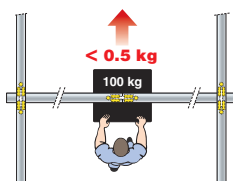

Pushing force in the centre
Rolling effort less than 0.5 kg for a load of 100 kg

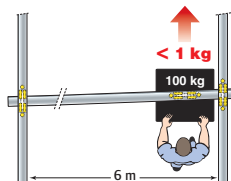

Pushing force on one side
Rolling effort less than 1 kg for a load of 100 kg

Starting >>>>> Moving >>>>> Positioning

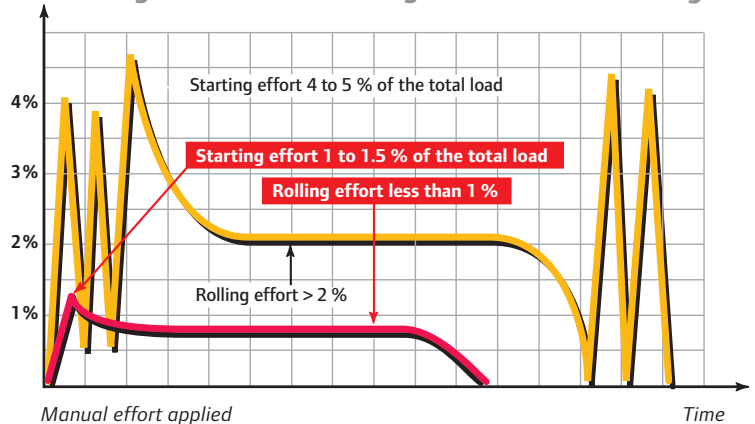

Typical enclosed rail systems
Ingersoll Rand enclosed rail systems

Rail Systems

Profiles

Quality steel and aluminum rail systems

Ingersoll Rand rails are available in two different materials and five different sizes to meet your specific material handling needs. The enclosed rail systems design reduces the accumulation of dirt and grime on the internal rolling surfaces, thus reducing rolling effort.

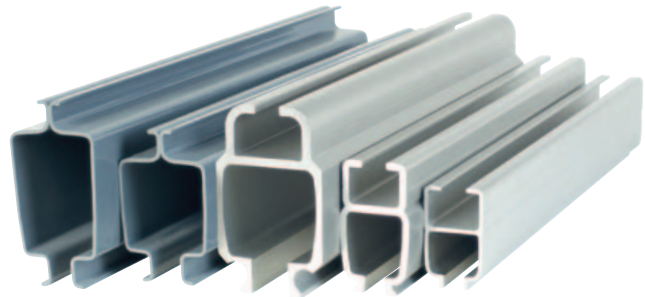

The Ingersoll Rand rail systems **ADVANTAGE**

- ▶ **Lightweight and ergonomic:** less than 1 percent rolling resistance
- ▶ **Modular and flexible:** bolted together; no welding required
- ▶ **Clean, maintenance-free operation:** no lubrication required
- ▶ **Safety:** designed to meet or exceed all national and international standards

Lightweight aluminum profiles

- ▶ Lightweight and available for long spans
- ▶ Extruded from aluminum
- ▶ Clear anodized for a smooth, clean, corrosive-free surface

Rugged steel profiles

- ▶ Roll formed from 9 gauge (4 mm), A569 hot-rolled steel
- ▶ Spot welded with automated welder for maximum strength
- ▶ Powder-coat painted for durability and smoothness

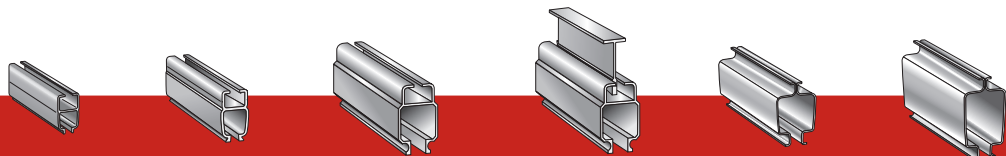

Rail model	ZRAT	ZRA1	ZRA2	ZRA2T	ZRS2	ZRS3
Material	Aluminum	Aluminum	Aluminum	Aluminum	Steel	Steel
Weight per m (kg)	3.0	5.5	11.3	22.3	11.9	13.2
Vertical height (mm)	97	124	177	330	150	181

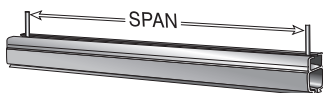

Span (m)	Load capacity (kg) /Deflexion 1/450						Load capacity (kg) /Deflexion 1/500 (UK standard)					
	ZRAT	ZRA1	ZRA2	ZRA2T	ZRS2	ZRS3	ZRAT	ZRA1	ZRA2	ZRA2T	ZRS2	ZRS3
1	372	734	1361	1361	1293	1293	372	734	1361	1361	1293	1293
1,5	311	734	1361	1361	1293	1293	280	734	1361	1361	1293	1293
2	175	595	1361	1361	1293	1293	157	536	1361	1361	1293	1293
2,5	112	381	1361	1361	1219	1293	101	343	1310	1361	1097	1293
3	78	264	1011	1361	847	1293	70	238	909	1361	762	1293
3,5	57	194	742	1361	622	1074	51	175	668	1361	560	967
4	44	149	568	1361	476	823	39	134	512	1361	429	740
4,5	35	118	449	1361	376	650	31	106	404	1361	339	585
5	28	95	364	1361	305	526	25	86	327	1361	274	474
5,5	23	79	301	1361	252	435	21	71	271	1361	227	392
6	19	66	253	1361	212	366	17	60	227	1361	190	329
6,5	–	56	215	1361	180	312	–	51	194	1259	162	280
7	–	49	186	1206	156	279	–	44	167	1085	140	242
7,5	–	42	162	1051	–	–	–	38	146	946	–	–
8	–	37	142	923	–	–	–	33	128	831	–	–
8,5	–	33	126	818	–	–	–	30	113	736	–	–
9	–	29	112	–	–	–	–	26	101	–	–	–



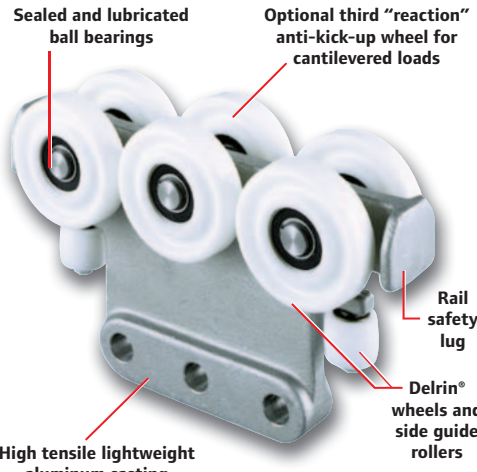



Advanced load trolleys

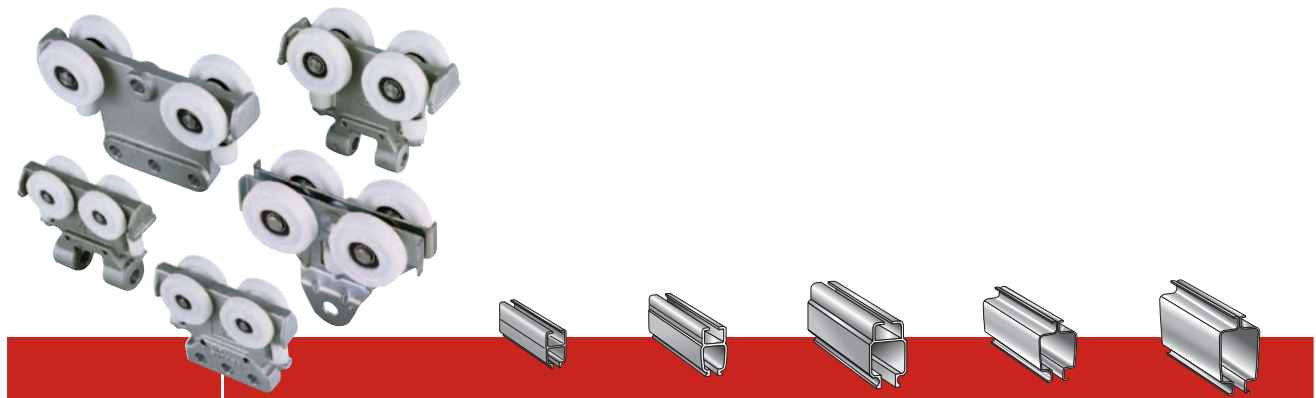

Ingersoll Rand trolleys are designed to work in conjunction with the enclosed track rail to reduce the rolling effort required to move a load. Only a force equal to 1 percent of the total rolling weight is needed when moving loads.

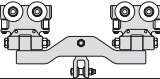
- ▶ **Lightweight:** trolleys are made from high-strength, lightweight aluminum castings
- ▶ **Injection molded wheels:** provide for clean, wear-free operation that resists flattening
- ▶ **Sealed precision bearings:** in wheels and side guide rollers, they provide long life and reduced maintenance
- ▶ **Rail safety lug:** prevents the body of the trolley from being pulled through the enclosed track rail
- ▶ **Versatile:** Ingersoll Rand-built trolleys are available for use in virtually every manufacturer's enclosed track rail system



For use with:	ZRAT	ZRA1	ZRA2	ZRS2	ZRS3
Simple trolley 	SWL: 225 kg Part no. 31057	SWL: 225 kg Part no. 30281	SWL: 450 kg Part no. 30172	SWL: 450 kg Part no. 30821	SWL: 450 kg Part no. 30821
Load trolley (with suspension axle) 	—	SWL: 225 kg Part no. 30304	SWL: 450 kg Part no. 30923	SWL: 450 kg Part no. 30842	SWL: 450 kg Part no. 30842
Hoist trolley 	SWL: 225 kg Part no. 31058	SWL: 225 kg Part no. 30313	SWL: 450 kg Part no. 30314	SWL: 450kg Part no. 30315	SWL: 450 kg Part no. 30315
Dual hoist trolley 	—	SWL: 450 kg Part no. 30303	SWL: 900 kg Part no. 30906	SWL: 900 kg Part no. 30830	SWL: 900 kg Part no. 30830
3 hole trolley 	SWL: 225 kg Part no. 31056	SWL: 225 kg Part no. 30279	SWL: 450 kg Part no. 30015	SWL: 450 kg Part no. 30510	SWL: 450 kg Part no. 30510
Reaction trolley (for cantilevered loads) 	—	—	SWL: 450 kg Part no. 30016	SWL: 450 kg Part no. 30511	—
Bumper trolley  Part no. XXXXX-1200, L = 305 mm Part no. XXXXX-2400, L = 610 mm Part no. XXXXX-3600, L = 915 mm Part no. XXXXX-4800, L = 1220 mm	—	Part no. 30307-1200 30307-2400 30307-3600 30307-4800	Part no. 30148-1200 30148-2400 30148-3600 30148-4800	Part no. 30148-1200 30148-2400 30148-3600 30148-4800	Part no. 30148-1200 30148-2400 30148-3600 30148-4800

Note: the ZRA1 monorails use the same components as the ZRA1 bridge cranes (hanger kits, load trolleys, etc), except dual hoist trolley, part no. 30303.

Rail Systems

While Ingersoll Rand offers both articulating and rigid end trucks to match the material handling application, the primary system sold utilizes the articulating end truck. This feature maximises the ability of the operator to precisely position loads, by allowing him to move only the portion of the bridge crane near the load. This results in dramatic improvements over typical rigid end truck systems, which require the user to move the entire mass of the bridge crane for each operation.



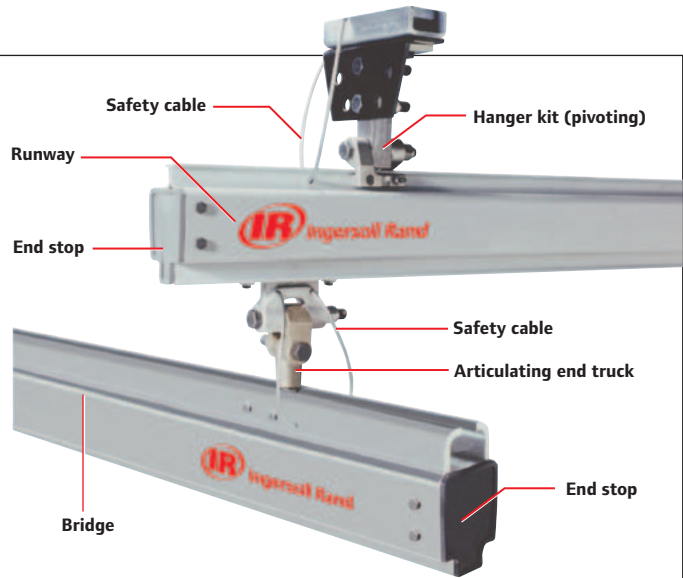







Ingersoll Rand offers a wide variety of hangers to attach to virtually any type of overhead steel. Available in either rigid (anti-compression) or pivoting styles to match the material handling operation, the hangers come in fixed or adjustable lengths for all rails.

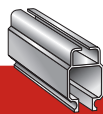
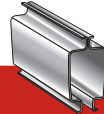

Articulating end trucks

- ▶ Maximize the ability of the operator to precisely position the load
- ▶ Reduce fatigue by allowing the operator to move only the portion of the bridge crane near the load
- ▶ Dramatic improvements over typical rigid end-truck systems, which require the user to move the entire mass of the bridge crane for each operation









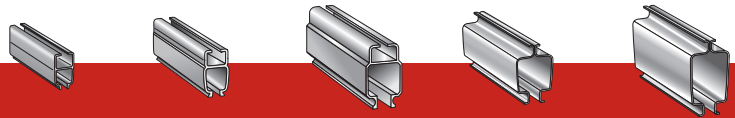

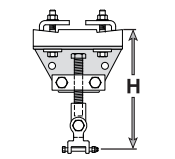
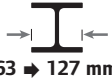
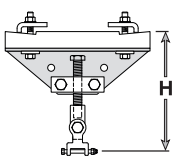

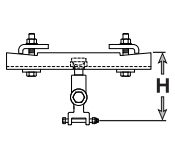

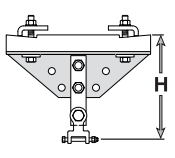
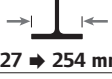
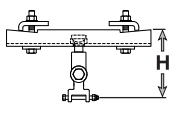

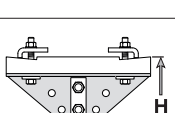
					Other brands	
For use with:	Z RAT	Z RA1	Z RA2	Z RS2 & Z RS3	KBK1	KBK1 & KBK2L
	SWL: 225 kg Part no. 31059	SWL: 225 kg Part no. 30283	SWL: 450 kg Part no. 30909	SWL: 450 kg Part no. 30822	SWL: 225 kg Part no. 30283	SWL: 450 kg Part no. 30639
	SWL: 450 kg Part no. 31060	SWL: 450 kg Part no. 30286	SWL: 900 kg Part no. 30911	SWL: 900 kg Part no. 30826	SWL: 450 kg Part no. 30286	SWL: 900 kg Part no. 30846
	SWL: 225 kg Part no. 31059	SWL: 225kg Part no. 30283	SWL: 450 kg Part no. 30909	SWL: 450 kg Part no. 30822	SWL: 225 kg Part no. 30283	SWL: 450 kg Part no. 30639
	SWL: 450 kg Part no. 31060	SWL: 450 kg Part no. 30286	SWL: 900 kg Part no. 30911	SWL: 900 kg Part no. 30826	SWL: 450 kg Part no. 30286	SWL: 900 kg Part no. 30846
	—	SWL: 225 kg Part no. 30295	SWL: 450 kg Part no. 30176	SWL: 450 kg Part no. 30824	SWL: 225 kg Part no. 30295	SWL: 450 kg Part no. 30927
	—	SWL: 450 kg Part no. 30272	SWL: 900 kg Part no. 30177	SWL: 900 kg Part no. 30828	SWL: 450 kg Part no. 30272	SWL: 900 kg Part no. 30643
	—	SWL: 225 kg Part no. 30320	SWL: 450 kg Part no. 30913	SWL: 450 kg Part no. 30597	SWL: 225 kg Part no. 30320	SWL: 450 kg Part no. 30563
	—	SWL: 450 kg Part no. 30298	SWL: 900 kg Part no. 30915	SWL: 900 kg Part no. 30599	SWL: 450 kg Part no. 30298	—

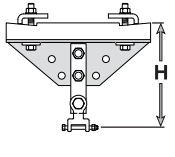
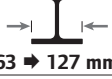
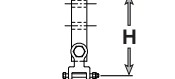
Hanger kits

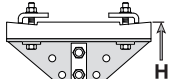
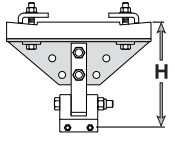

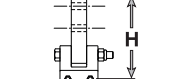
- ▶ Attach to I-beam, angle iron, C-channel, and other overhead steel shapes
- ▶ Close and rigid style hangers available for low headroom
- ▶ Adjustable-height hangers provide easy leveling
- ▶ Sway bracing for hanger drops >600 mm for added safety and stability

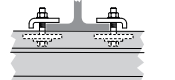
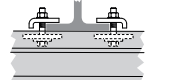

For use with:		ZRAT	ZRA1	ZRA2	ZRS2	ZRS3	
Adjustable ± 22 mm		 63 → 127 mm	H = 287 mm Part no. 30287-006	H = 287 mm Part no. 30287-006	H = 295 mm Part no. 30195-006	H = 273 mm Part no. 30814-006	H = 273 mm Part no. 30814-006
		 63 → 127 mm	H = 439 mm Part no. 30287-012	H = 439 mm Part no. 30287-012	H = 447 mm Part no. 30195-012	H = 425 mm Part no. 30814-012	H = 425 mm Part no. 30814-012
		 127 → 254 mm	H = 287 mm Part no. 30288-006	H = 287 mm Part no. 30288-006	H = 295 mm Part no. 30196-006	H = 273 mm Part no. 30815-006	H = 273 mm Part no. 30815-006
		 127 → 254 mm	H = 439 mm Part no. 30288-012	H = 439 mm Part no. 30288-012	H = 447 mm Part no. 30196-012	H = 425 mm Part no. 30815-012	H = 425 mm Part no. 30815-012
Short		 63 → 127 mm	H = 156 mm Part no. 30300	H = 156 mm Part no. 30300	H = 164 mm Part no. 30921	H = 142 mm Part no. 30840	H = 142 mm Part no. 30840
		 127 → 254 mm	H = 156 mm Part no. 30301	H = 156 mm Part no. 30301	H = 164 mm Part no. 30922	H = 142 mm Part no. 30841	H = 142 mm Part no. 30841
Parallel beam		 63 → 127 mm	H = 292 mm Part no. 30290	H = 292 mm Part no. 30290	H = 301 mm Part no. 30199	H = 279 mm Part no. 30817	H = 279 mm Part no. 30817
		 127 → 254 mm	H = 292 mm Part no. 30291	H = 292 mm Part no. 30291	H = 301 mm Part no. 30900	H = 279 mm Part no. 30818	H = 279 mm Part no. 30818
		Block mount	H = 244 mm Part no. 30289	H = 244 mm Part no. 30289	H = 253 mm Part no. 30198	H = 231 mm Part no. 30816	H = 231 mm Part no. 30816
Perpen- dicular beam		 63 → 127 mm	H = 292 mm Part no. 30292	H = 292 mm Part no. 30292	H = 301 mm Part no. 30901	H = 279 mm Part no. 30819	H = 279 mm Part no. 30819
		 63 → 127 mm	H = 292 mm Part no. 30293	H = 292 mm Part no. 30293	H = 301 mm Part no. 30902	H = 279 mm Part no. 30820	H = 279 mm Part no. 30820
		Block mount	H = 244 mm Part no. 30285	H = 244 mm Part no. 30285	H = 253 mm Part no. 30193	H = 231 mm Part no. 30813	H = 231 mm Part no. 30813
Rigid		Rigid mount	Part no. 30227	Part no. 30227	Part no. 30052	-	-

Rail Systems

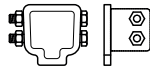
Components

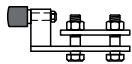
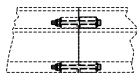
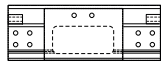
		ZRAT	ZRA1	ZRA2	ZRS2	ZRS3
For use with:						
End stop		Part no. 31022	Part no. 30275	Part no. 30183	Part no. 30804	Part no. 30808
Redundant		Part no. 31024	Part no. 30277	Part no. 30185	Part no. 30806	Part no. 30810
Adjustable end stop		Part no. 30738	Part no. 30738	Part no. 30733	Part no. 30733	Part no. 30733
Splice bolt kit		Part no. 31020	Part no. 30231	Part no. 30057	Part no. 30515	Part no. 30515
Inspection gate		—	Part no. ZRA1-IG-ADJ06	Part no. ZRA2-IG-ADJ06	—	—

Inspection gate

- ▶ Provide simple inspection of trolleys and end trucks



Adjustable stop

- ▶ Easily adjust travel limit of bridge crane or load trolley

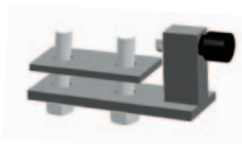

Curved rails

- ▶ Provide simple single-axis transfer
- ▶ Curved sections available for navigating obstructions



R		R	
ZRA1		ZRS2	
0.92 m	15°	1.5 m	10°
0.92 m	30°	1.5 m	15°
0.92 m	45°	1.5 m	30°
0.92 m	60°	1.5 m	45°
0.92 m	90°	1.5 m	60°
—	—	1.5 m	90°

TIP

Load capacity:

To correctly calculate the load capacity of each component described in the previous pages, please apply the following rule of calculation:

$$A + B + (C:2).$$

A = Load to be moved

B = Balancer or hoist weight

C = Weight of the lower rails and trolleys divided by 2.

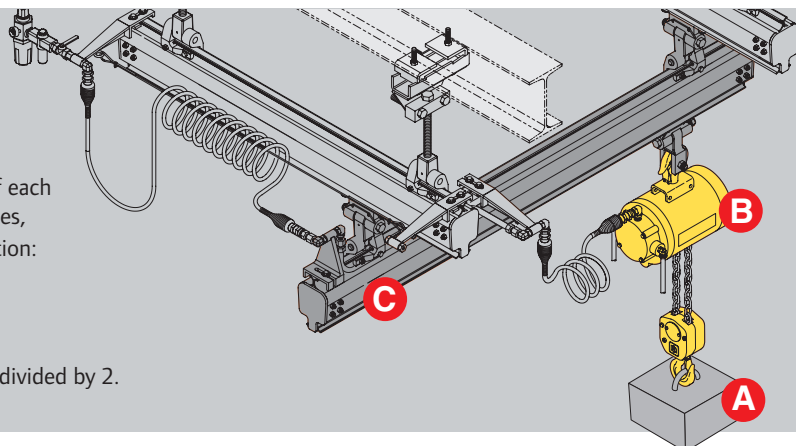

Power supply

Air supply kits:

- ▶ Available in both 3/8" and 1/2" to fit application needs
- ▶ Includes filter regulator to ensure clean regulated air supply
- ▶ Provides complete utilisation of the bridge and runway system

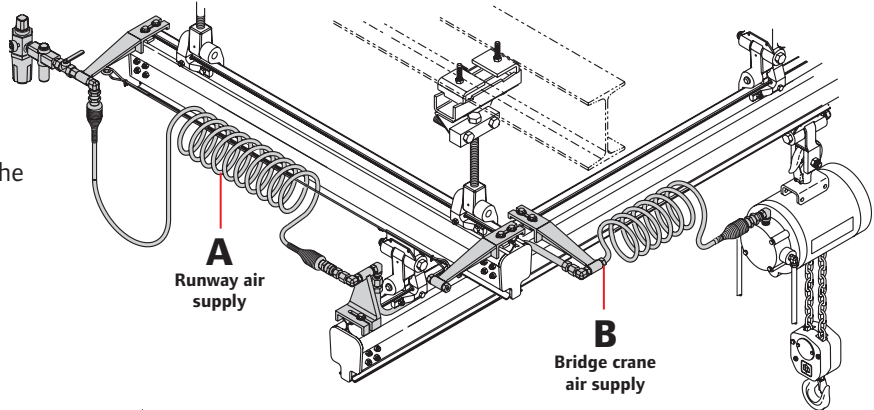

A Runway air supply

Top view

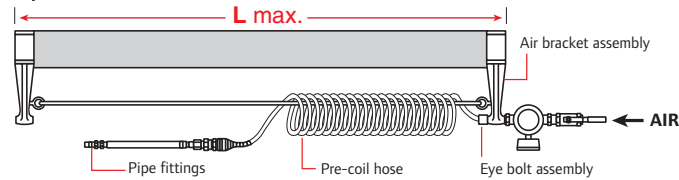

Side view

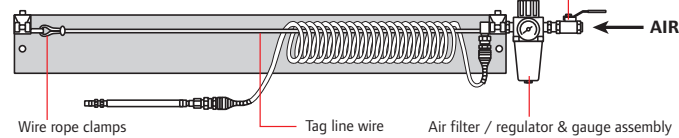

B Bridge crane air supply

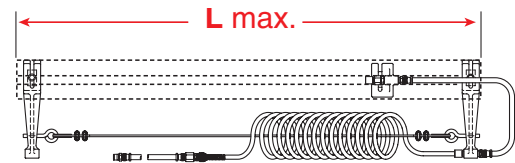

Max. length L	Ø 3/8"	Ø 1/2"
15 m	90000-1	90001-1
22.5 m	90000-2	90001-2
30 m	90000-3	90001-3
37.5 m	90000-4	90001-4
45 m	90000-5	90001-5

Max. length L	Ø 3/8"	Ø 1/2"
9 m	ZHS90025	ZHS90026

Electrical supply kits:

- ▶ Available with or without flat conductor cable
- ▶ Secured to rail system eliminating interference with operator



Festooning trolleys

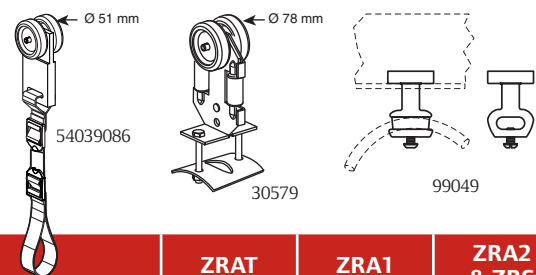

	ZRAT	ZRA1	ZRA2 & ZRS
For electric supply			
Festoon trolley	—	54039086	54039078
Slider	99048	99048	99049
For air or electric supply			
Festoon trolley	31005 + 31011	30579	30581



Jib Cranes

Solutions for compact workstations

Ingersoll Rand offers:

- ▶ 220° or 360° rotation
- ▶ Floor or wall mount
- ▶ Standard or low profile
- ▶ Capacities to 860 kg

Features

The Ingersoll Rand Jib Crane with a rail option use precision Ingersoll Rand Enclosed Track rail for the boom, resulting in an ergonomic, lightweight boom with best-in-class rolling resistance.

The Ingersoll Rand jib crane **ADVANTAGE**

- ▶ **Precision:** made from precision Ingersoll Rand aluminum rail, resulting in a lightweight, easy-to-move boom with low rolling resistance for smooth travel.
- ▶ **Ergonomic:** Ingersoll Rand aluminum rails offer less than 1% of rolling effort.
- ▶ **Cost Effective:** Jib cranes are an inexpensive solution for short transfer applications.

Boom length

- ▶ Radius of coverage area
- ▶ Most ergonomic operation is closer to end of boom

Boom underclearance

- ▶ Distance from floor to bottom of boom
- ▶ Available up to 4.27 m, 3.65 m standard

Overall height

- ▶ Distance from floor to top of jib crane
- ▶ 900J Series offers lowest overall height

Boom profile

- ▶ Clean, lightweight anodized aluminum

Note: for proper installation of a floor-supported jib crane system a minimum of a 15 cm thick reinforced concrete floor is required.

Consult a registered structural engineer before installing the jib crane.

This is required to ensure local building codes, possible seismic loading considerations and variance in concrete slab and soil conditions are addressed.

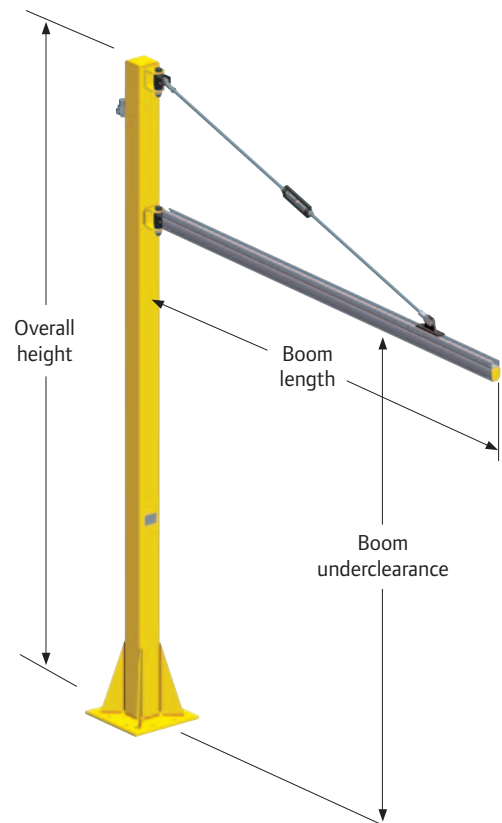

How to select:

Rotation

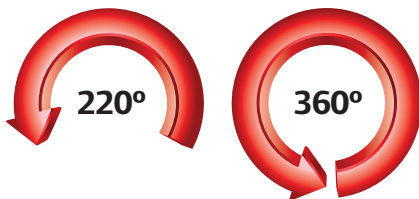

700J Series

800J & 900J Series

Load capacity

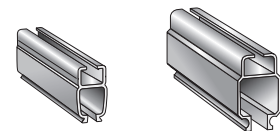

Boom profile

Jib Series	Mounting type	Load capacity (kg)	Load capacity (kg)
700J	Floor	165	725
700J	Wall	360	860
800J	Floor	370	370
900J	Floor	—	370

Jib Cranes

700J Series Floor mount

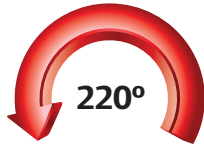

ZRA1 aluminum boom (up to 165 kg)
Standard underclearance 3m and 3.65 m



Model no.	Underclearance (m)	Boom length (m)	Overall height (m)	Capacity (kg)
7165JA1F30365-EU	3,65	3	4.63	165
7115JA1F40365-EU	3,65	4	4.63	115
7090JA1F50365-EU	3,65	5	4.63	90
7165JA1F30300-EU	3,00	3	3.97	165
7115JA1F40300-EU	3,00	4	3.97	115
7090JA1F50300-EU	3,00	5	3.97	90

Any special lengths, please consult factory.

ZRA2 aluminum boom (up to 725 kg)
Standard underclearance 3m and 3.65 m

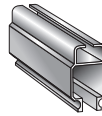

Model no.	Underclearance (m)	Boom length (m)	Overall height (m)	Capacity (kg)
7725JA2F30365-EU	3,65	3	4.63	725
7520JA2F40365-EU	3,65	4	4.63	520
7360JA2F50360-EU	3,65	5	4.63	360
7725JA2F30300-EU	3,00	3	3.97	725
7520JA2F40300-EU	3,00	4	3.97	520
7360JA2F50300-EU	3,00	5	3.97	360

Any special lengths, please consult factory.

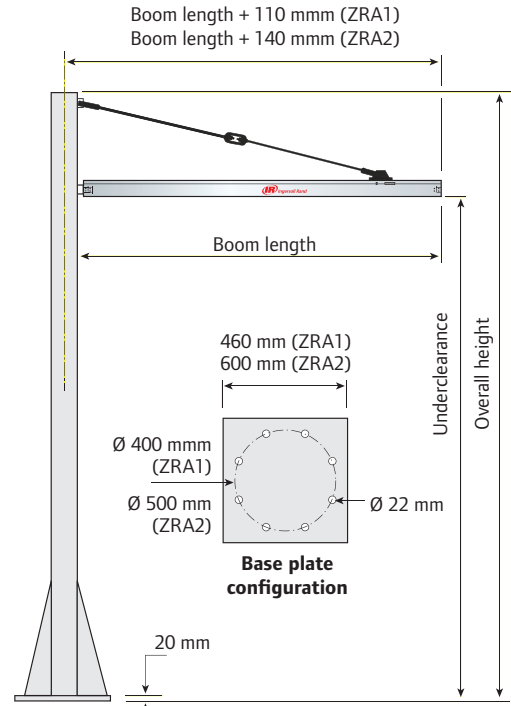

Standard columns: 150 mm x 150 mm x 8 mm with ZRA1 boom, 200 mm x 200 mm x 12 mm with ZRA2 boom.

700J Series Wall mount

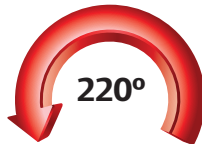

150 mm (except ZRA2 with 5.5 m boom: 200 mm)

Overall height

235 mm (except ZRA2 with 5.5 m boom: 300 mm)

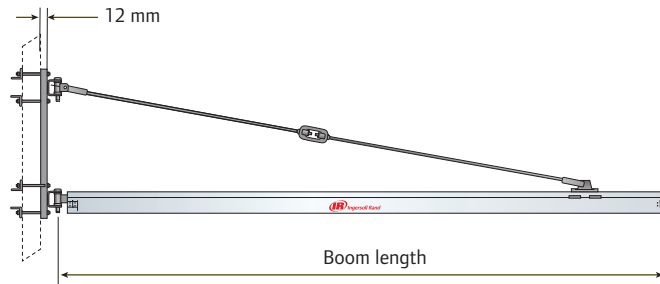

ZRA1 aluminum boom (up to 363 kg)

Model no.	Boom length (m)	Overall height (m)	Capacity (kg)
7360JA1W30-EU	3	1.1	360
7245JA1W40-EU	4	1.1	245
7110JA1W50-EU	5	1.1	110

Any special lengths, please consult factory.

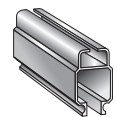

ZRA2 aluminum boom (up to 863 kg)

Model no.	Boom length (m)	Overall height (m)	Capacity (kg)
7860JA2W30-EU	3	1.1	860
7770JA2W40-EU	4	1.1	770
7450JA2W50-EU	5	1.4	450

Any special lengths, please consult factory.

800J Series Floor mount



ZRA1 aluminum boom (up to 372 kg)
With 3.65 m standard underclearance ⁽¹⁾



Model no.	Boom length (m)	Capacity (kg)	Dimension U (mm)	Weight (kg)
8082JA1F04144	1.22	370	1069	189
8055JA1F06144	1.83	250	1069	192
8041JA1F08144	2.44	185	1069	196
8033JA1F10144	3.05	150	1069	200
8027JA1F12144	3.66	120	1069	203
8023JA1F14144	4.27	105	1069	207
8020JA1F16144	4.88	90	1069	210
8018JA1F18144	5.49	80	1069	214
8016JA1F20144	6.10	70	1069	218

(1) Max. underclearance available: 4.27 m

ZRA2 aluminum boom (up to 372 kg)
With 3.65 m standard underclearance ⁽¹⁾

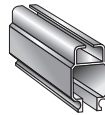

Model no.	Boom length (m)	Capacity (kg)	Dimension U (mm)	Weight (kg)
8082JA2F04144	1.22	370	1099	189
8055JA2F06144	1.83	250	1099	192
8041JA2F08144	2.44	185	1099	196
8033JA2F10144	3.05	150	1099	200
8027JA2F12144	3.66	120	1099	203
8023JA2F14144	4.27	105	1099	207
8020JA2F16144	4.88	90	1099	210
8018JA2F18144	5.49	80	1099	214
8016JA2F20144	6.10	70	1099	218

(1) Max. underclearance available: 4.27 m

900J Series Floor mount



ZRA2T aluminum boom (up to 372 kg)
With 3.65 m standard underclearance ⁽¹⁾

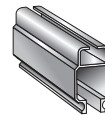

Model no.	Boom length (m)	Capacity (kg)	Dimension U (mm)	Weight (kg)
9082JA2TF04144	1.22	370	340	186
9055JA2TF06144	1.83	250	340	200
9041JA2TF08144	2.44	185	340	213
9033JA2TF10144	3.05	150	340	227
9027JA2TF12144	3.66	120	340	240
9023JA2TF14144	4.27	105	340	254
9020JA2TF16144	4.88	90	340	268
9018JA2TF18144	5.49	80	340	281
9016JA2TF20144	6.10	70	340	295

(1) Max. underclearance available: 4.27 m

800J Series

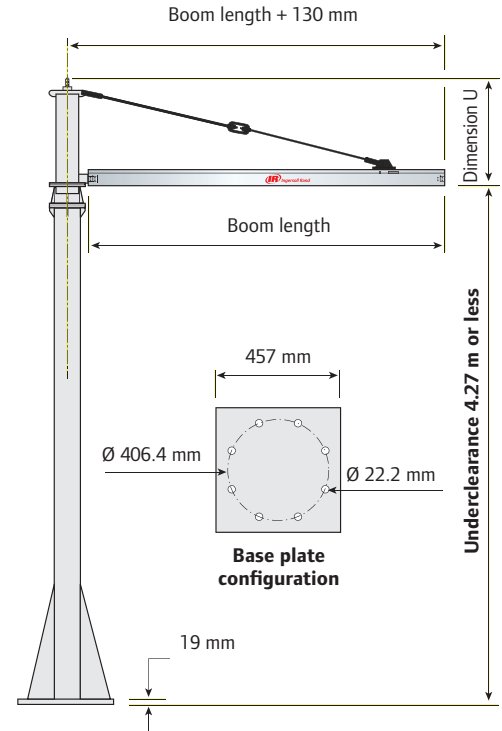

900J Series

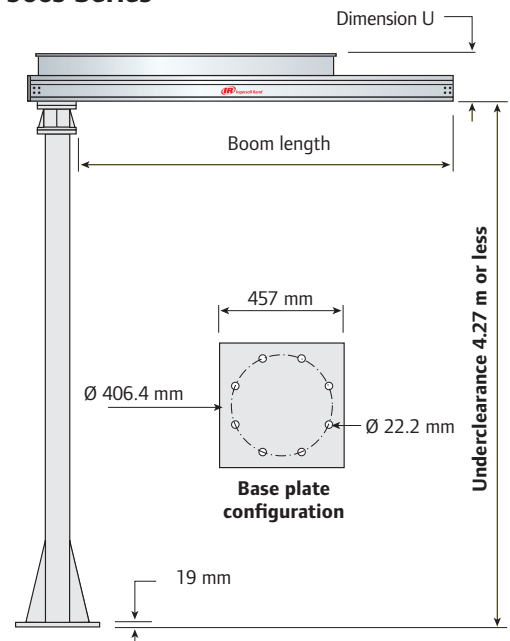

Standard columns 152 mm x 152 mm x 6 mm, designed for 4.27 m underclearance or less.

Jib Cranes

Jib cranes model identification codes

700J Series (example: **7360JA2F50300-EU**)

Style	Load capacity	Jib	Rail type	Mount type	Boom length	Underclearance	-EU
7 = 700 Series, 220° rotation	E.g. 360 = 360 kg <i>(Load capacities available: floor mount models: 90, 115, 165, 360, 520 and 725 kg — wall mount models: 110, 245, 360, 450, 770 and 860 kg)</i>	J = Jib	A1 = ZRA1 A2 = ZRA2	F = Floor W = Wall	30 = 3 m 40 = 4 m 50 = 5 m	365 = 3,65 m 300 = 3,00 m	CE model

800J & 900J Series (example: **9055JA2TF06144**)

Style	Load capacity	Jib	Rail type	Mount type	Boom length	Underclearance
8 = 800 Series, 360° rotation 9 = 900 Series, 360° rotation	E.g. 033 = 330 lb (= 150 kg)	J = Jib	A1 = ZRA1 (800J Series) A2 = ZRA2 (800J Series) A2T = ZRA2T (900J Series only)	F = Floor	04 = 1.22 m 06 = 1.83 m 08 = 2.44 m 10 = 3.05 m 12 = 3.66 m 14 = 4.27 m 16 = 4.88 m 18 = 5.49 m 20 = 6.10 m	Standard underclearance = 3.65 m (Max. underclearance available = 4.27 m) <i>For non-standard underclearance, indicate the desired size in inches at the end of the model no, in lieu of the standard size of 144 inches. E.g. 9023JA2TF14144102 (102" = 2.60 m)</i>

Jib cranes accessories

Load trolleys

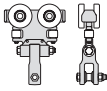
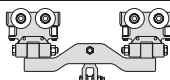
Model no		Boom type	Capacity (kg)
30313		ZRA1	225
30303		ZRA1	450
30314		ZRA2	450
30315		ZRS2	450
30906		ZRA2	900
30830		ZRS2	900

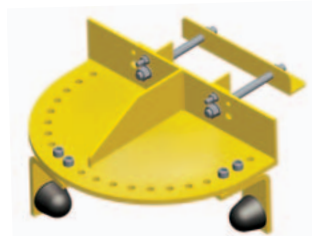

Adjustable boom rotation stops

Model no	Jib Series
42982M	700J Series / 220° rotation
42203000	800J and 900J Series / 360° rotation

Also available upon request:

- ▶ Portable pallet base — Provides jib mobility using a fork truck compatible base
- ▶ Custom designs for special applications

Air supply kit

Includes filter regulator assembly with brackets, tagline assembly, and coiled hose.

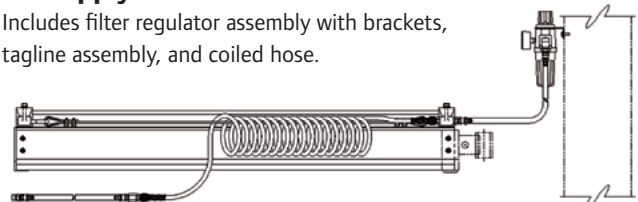

Model no	Size (in)
ZHS90027	3/8
ZHS90028	1/2

Electrification kit

Includes 2 suspension brackets, 1 anchor bracket, variable length tag line wire with clamps and eyebolt assembly, and cable trolleys.

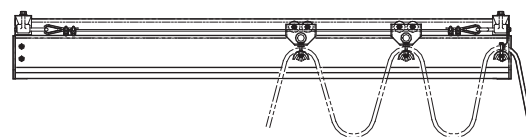

Model no	Boom (m)
ZHS90090-1	Up to 4 m
ZHS90090-2	Greater than 4 m



Balancers

The strength behind Ingersoll Rand ergonomic handling

Ingersoll Rand offers:

- ▶ BW pneumatic balancers
- ▶ IntelLIFT® intelligent assist devices
- ▶ Mechanical spring balancers

BW-Series Pneumatic Balancers

Features

Meeting the needs of today's material handling applications requires an ergonomic lift assist that interacts with the operator. The balancer offers lifting solutions to meet these needs through float and built in safety features.

The Ingersoll Rand pneumatic balancer **ADVANTAGE**

- ▶ **Precise, strain-free positioning:** float leaves both hands free to raise, lower, or shift the load with virtually no resistance; no more "hoist control" hit-and-miss spotting.
- ▶ **Simple adjustment:** clear access to air-flow calibration controls allows quick, easy adjustment of the float.
- ▶ **Rugged reliability:** for continuous duty with minimal maintenance.

PLUS:

- ▶ **Low air consumption:** approximately 1/8 cfm required per cycle (one fiftieth of that of an air hoist) means very low energy costs.
- ▶ **Clean, oil-free operation:** pre-lubricated design eliminates air line lubrication and oil mist exhaust; ideal for food processing and clean manufacturing environments

Safety is standard

- ▶ Built-in overload protection: the lifted load can never exceed the unit's maximum rated capacity
- ▶ Minimal cable recoil due to loss of load: if the load is accidentally lost, a centrifugal brake (Z brake) automatically stops rapid upward cable travel

Versatile configuration

- ▶ Wide range of capacities up to 450 kg
- ▶ Added protection: the optional Z Stop offers protection against the drifting of loads in the event the main air supply is lost
- ▶ Cable travel 1 m to 3 m depending on the model
- ▶ Controls: ZA (pendant) controls let you handle varying loads; a BA (single) balance control is ideal for a constant load, and an EA for 2 loads
- ▶ Mounting: suspension kits for Ingersoll Rand and other enclosed track manufacturers as well as I-beam, patented track, and hook mount
- ▶ CE certification: meets the requirements for the European community

Z brake safety retraction system (patent no. 5,522,581): Standard on all units, prevents violent retraction in the event of a sudden release or loss of load. The brake will also eliminate excessive upward acceleration of a no load hook when the "up" button is pressed in fully.



Suspension lugs: Fits all Ingersoll Rand suspensions and most trolleys from other manufacturers.

Rugged steel housing: All steel housing for added durability

Injection-molded reel: Engineered plastic for excellent durability and wear resistance

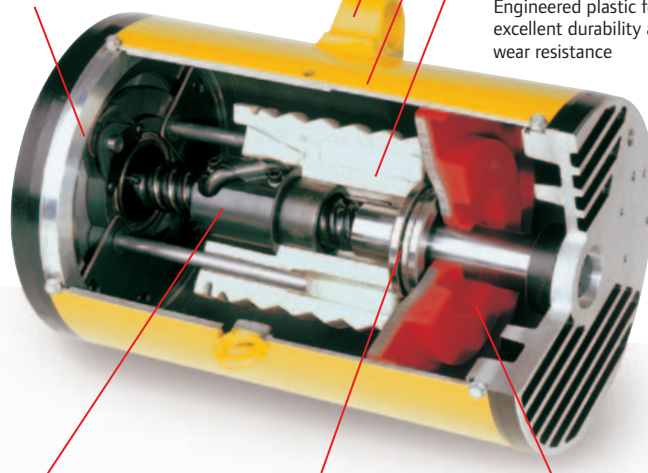

Anti-friction ball screw: Creates smooth rotation path for the cable reel.

Heavy-duty thrust bearing: Absorbs piston force and transfers smooth reel rotation over the ball screw.

Low-friction cable guide (not shown): Ensures smooth cable feed on and off the reel.



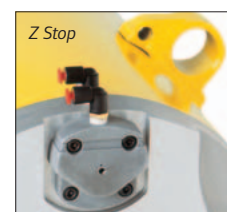

Air chamber and piston: Forms the heart of the unit. Air entering the chamber pushes the piston to rotate the spool, wind the cable, and lift the load. Exhausting air lowers the load. Regulating this flow balances the load, creating a zero gravity float.

Z Stop:

The optional Z Stop is a patented device that will eliminate the down-drift of suspended loads or tools during shut down or at night when the air supply is shut off. The Z Stop will stop drift within 150 mm and put the Balance Air into a mechanically locked position preventing damage to tools or objects below the suspended load. Available for use on all 254 mm diameter units.



BW-Series Pneumatic Balancers

 <p>BW</p> <p>Basic unit, without control</p> <p>Features:</p> <ul style="list-style-type: none"> ▶ Standard balancer features ▶ No control <p>Suitable for:</p> <ul style="list-style-type: none"> ▶ Integration with end effector 	 <p>ZA</p> <p>Balancer with pendant control</p> <p>Features:</p> <ul style="list-style-type: none"> ▶ Ergonomic up/down pendant control ▶ High speed precise positioning ▶ 3.7 m standard hose length <p>Suitable for:</p> <ul style="list-style-type: none"> ▶ Pick and place ▶ Precision assembly 	 <p>BA</p> <p>Balancer with servo control</p> <p>Features:</p> <ul style="list-style-type: none"> ▶ Single balance control for single load balancing ▶ Maintains constant tension through full range of motion <p>Suitable for:</p> <ul style="list-style-type: none"> ▶ Tool balancing ▶ Weld gun suspension ▶ Fixture suspension 	 <p>EA</p> <p>Balancer with high load, low load, no load control</p> <p>Features:</p> <ul style="list-style-type: none"> ▶ Load balancing for 3 loads (high, low, no load) ▶ Pendant with rotary thumb switch to select load ▶ 3.7 m standard hose length <p>Suitable for:</p> <ul style="list-style-type: none"> ▶ Multiple load balancing ▶ End effector balancing (loaded/unloaded)
---	---	--	--



Recommended working load capacity :
10 to 80 % of SWL

Recommended working load capacity :
10 to 60 % of SWL

Technical specifications

Model no. / B control	Model no. / ZA control	Model no. / BA control	Model no. / EA control	SWL @ 500kPa (kg)	SWL @ 600kPa (kg)	SWL @ 700kPa (kg)	Lifting travel (m)	Body diameter (mm)	Weight (kg)
Single wire rope									
BW015080 ⁽¹⁾	ZAW015080 ⁽¹⁾	BAW015080 ⁽¹⁾	EAW015080 ⁽¹⁾	49	58	68	2.0	165	23
BW020120	ZAW020120	BAW020120	EAW020120	65	78	90	3.0	254	28
BW020120S ⁽²⁾	ZAW020120S ⁽²⁾	BAW020120S ⁽²⁾	EAW020120S ⁽²⁾	65	78	90	3.0	254	28
BW032080S ⁽²⁾	ZAW032080S ⁽²⁾	BAW032080S ⁽²⁾	EAW032080S ⁽²⁾	104	124	145	2.0	254	28
BW035080 ⁽¹⁾	ZAW035080 ⁽¹⁾	BAW035080 ⁽¹⁾	EAW035080 ⁽¹⁾	113	136	160	2.0	254	28
BW050080	ZAW050080	BAW050080	EAW050080	162	194	225	2.0	254	50
BW050080S ⁽²⁾	ZAW050080S ⁽²⁾	BAW050080S ⁽²⁾	EAW050080S ⁽²⁾	162	194	225	2.0	254	50
Reeved wire rope									
BW040060	ZAW040060	BAW040060	EAW040060	130	155	180	1.5	254	30
BW040060S ⁽²⁾	ZAW040060S ⁽²⁾	BAW040060S ⁽²⁾	EAW040060S ⁽²⁾	130	155	180	1.5	254	30
BW065040S ⁽²⁾	ZAW065040S ⁽²⁾	BAW065040S ⁽²⁾	EAW065040S ⁽²⁾	208	248	290	1.0	254	30
BW070040 ⁽¹⁾	ZAW070040 ⁽¹⁾	BAW070040 ⁽¹⁾	EAW070040 ⁽¹⁾	226	272	320	1.0	254	30
BW100040	ZAW100040	BAW100040	EAW100040	324	388	450	1.0	254	52
BW100040S ⁽²⁾	ZAW100040S ⁽²⁾	BAW100040S ⁽²⁾	EAW100040S ⁽²⁾	324	388	450	1.0	254	52
Tandem wire rope									
BW040120	ZAW040120	BAW040120	EAW040120	130	155	180	3.0	254	56
BW040120S ⁽²⁾	ZAW040120S ⁽²⁾	BAW040120S ⁽²⁾	EAW040120S ⁽²⁾	130	155	180	3.0	254	56
BW065080S ⁽²⁾	ZAW065080S ⁽²⁾	BAW065080S ⁽²⁾	EAW065080S ⁽²⁾	208	248	290	2.0	254	56
BW070080 ⁽¹⁾	ZAW070080 ⁽¹⁾	BAW070080 ⁽¹⁾	EAW070080 ⁽¹⁾	226	272	320	2.0	254	56
BW100080	ZAW100080	BAW100080	EAW100080	324	388	450	2.0	254	100
BW100080S ⁽²⁾	ZAW100080S ⁽²⁾	BAW100080S ⁽²⁾	EAW100080S ⁽²⁾	324	388	450	2.0	254	100

1) Not available with Z-Stop safety device.

2) Model delivered with Z-Stop as standard.

BW-Series Pneumatic Balancers

Options

Model identification codes

Example: **ZAW065040SS3**

Option code	Description	Part no. / 165 mm Ø balancer	Part no. / 254 mm Ø balancer
Control			
B	Basic - No control	–	–
ZA	Pendent control	15300-12	15300-12
BA	Single balance control	15320	15330
EA	Hi, low, no load control	15310-12	15310-12
Suspension			
00	No suspension	–	–
S2	IR ZRS2 steel rail	16300	16400
S3	IR ZRS3 steel rail	16300	16400
HM	Hook mount	16360	16460
TR ⁽¹⁾	T-Rail / I-Beam	16320	16420
AT	IR ZRAT alu. rail	16355	16455
A1	IR ZRA1 alu. rail	16305	16405
A2	IR ZRA2 alu. rail	16310	16410
K1	KBK1 (Demag)	16325	16425
K2	KBK2 (Demag)	16315	16415

(1) Only for 50, 66, 82 and 100 mm beam widths.



S2, S3, AT, A1, A2
For enclosed rails

TR
T-Rail / I-Beam
Only for 50 mm, 66 mm, 82 mm
and 100 mm beam widths

HM
Hook mount

Speed control kit, part no. 58267352

Regulates the inlet pressure of the balancer. Full control of lifting speed for any loads. Must be used with the ZA pendent control 15300. Specially designed for lightweight hook with heavy loads



Tri-Coil, Quad-Coil and Interlock options

TRI-COIL

Part no. 15300-TC-NH
Specially designed to integrate a mechanical handling device with an up and down control.

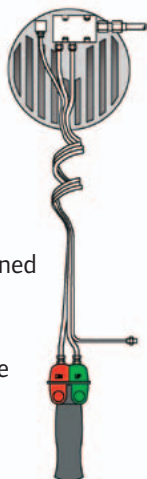

TRI-COIL + Interlock

Part no. 15300-TC-I-NH
Specially designed to integrate a simple handling device. Incorporates the Interlock safety device.



QUAD-COIL

Part no. 15300-QC-NH
Specially designed to integrate a pneumatic powered handling device (3rd air supply tube).

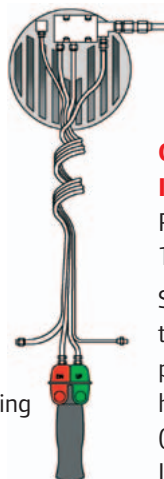

QUAD-COIL + Interlock

Part no. 15300-QC-I-NH
Specially designed to integrate a pneumatic powered handling device (3rd air supply tube). Incorporates the Interlock safety device.

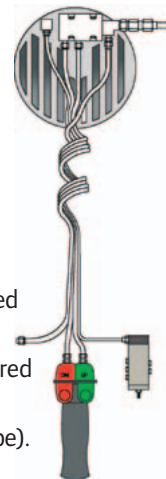

BW-Series Pneumatic Balancers

Dimensions

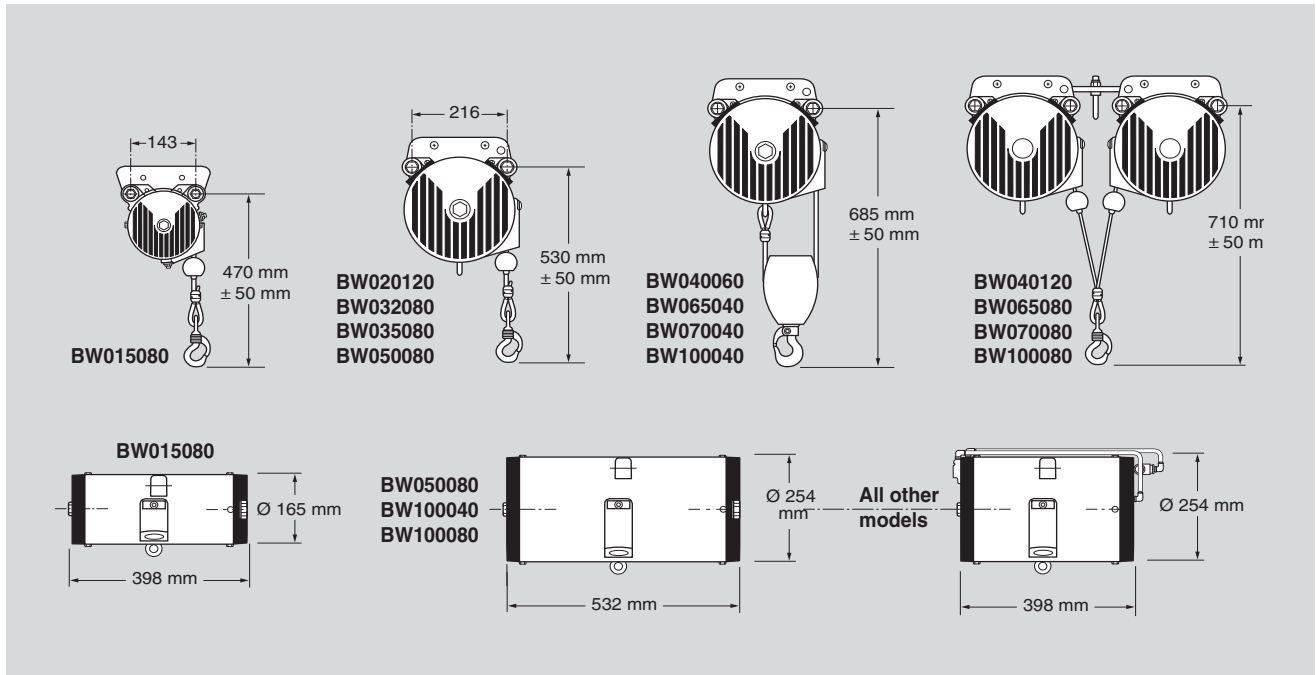

BAW 0.9 - 22 kg positioner

This air unit offers an incredible 0.9 to 22 kg load capacity and our exclusive flotation feature.

Standard features:

- ▶ **Performance:** float action provides ease of vertical travel, eliminating tension on load, making positioning capability far superior
- ▶ **Versatility:** no need to change model when making tool change; one model (BAW005060) covers entire 22 kg range
- ▶ **Headroom:** requires only 511 mm from bottom of rail to bottom of hook
- ▶ **Adjustment:** simple adjustment in seconds by means of external regulator
- ▶ **Sequencing:** can be sequenced via air signal to perform timed or "stepped" operation
- ▶ **Maintenance:** virtually maintenance-free. Normal maintenance can be done in place on the rail

Model no.	Load capacity (kg)	Lifting travel (m)	Body diameter (mm)	Weight (kg)
BAW005060	0.9 - 22	1.5	260	9.0



New

Now available with ergonomic up/down pendant control for high speed precise positioning

Model no. **ZAW005060HM-TC**

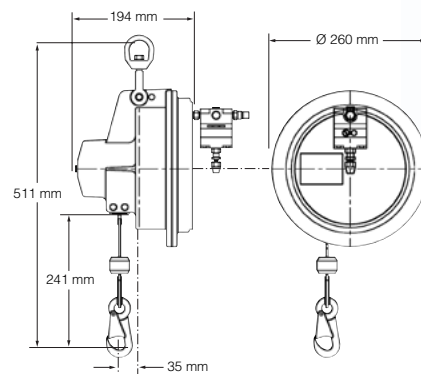

InteLIFT® Series Balancers

Intelligent lifting system

InteLIFT® is an intelligent assist device (IAD); it converts intuitive operator input into smooth, effortless up / down motion. The force-sensing control handle responds to operator input quickly and seamlessly for precise positioning of loads.

The Ingersoll Rand InteLIFT Balancer **ADVANTAGE**

- ▶ **Self-balancing:** intuitive speed control for different weights
 - ▶ **Hands-on maneuvering:** InteLIFT senses force input of the user and translates that to assisted lifting / lowering of the load without the need for up / down buttons
 - ▶ **Float mode:** throughout entire range of motion
 - ▶ **Robust design:** electric over air design allows continuous duty with minimal maintenance
 - ▶ **Part present:** eliminates potential to accidentally drop part
 - ▶ **3-Speed select:** enables speed selection to match application and operator comfort level
- Same green features as the Pneumatic Balancer**
- ▶ **Low air consumption**
 - ▶ **Clean, oil-free operation**



TiD-extra
 Industrial Technologies d.o.o.

Integrated InteLIFT® control module



Ergonomic control handle

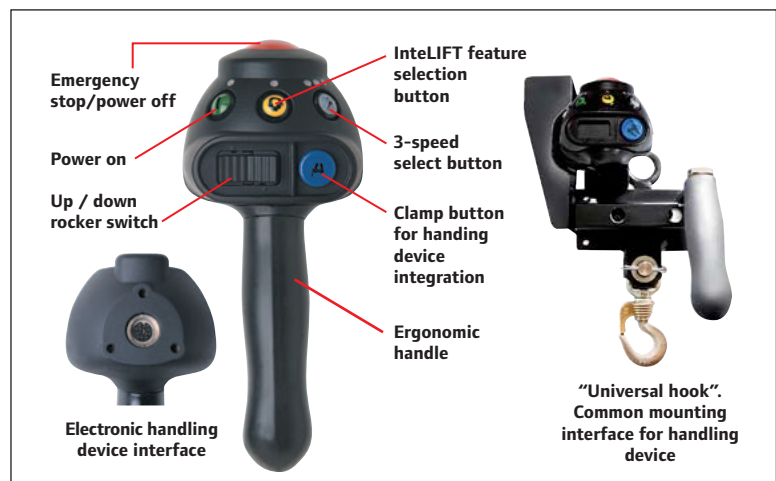

Control options



IB

InteLIFT® basic unit, without control

Features:

- ▶ No controls
- ▶ Standard InteLIFT features

Suitable for:

- ▶ Integration with end effector



IA

InteLIFT® with pendant control and pre-coil cable

Features:

- ▶ InteLIFT ergonomic pendant control handle with up/down rocker switch
- ▶ Precise, high-speed positioning
- ▶ 3.7 m twin bonded pre-coil cable including pre-coil air hose for handling device integration

Suitable for:

- ▶ Pick and place
- ▶ Precision assembly
- ▶ Floating capacity



IC

InteLIFT® with force-sensing control (without up/down buttons)⁽¹⁾

Features:

- ▶ InteLIFT ergonomic force-sensing control handle
- ▶ Intuitive up/down control
- ▶ 3.7 m twin bonded pre-coil cable including pre-coil air hose for handling device integration

Suitable for:

- ▶ High-cycle pick and place
- ▶ Precision assembly
- ▶ Multiple load capacity



IS

InteLIFT® with pendant control and straight cable

Features:

- ▶ InteLIFT ergonomic pendant control handle with up/down rocker switch
- ▶ Precise, high-speed positioning
- ▶ 3.7 m straight electric cable

Suitable for:

- ▶ Pick and place
- ▶ Precision assembly
- ▶ Floating capacity

(1) IC control option includes force sensing load cell which must be mounted to end effector for proper operation

Technical specifications

Model no. / B control	Model no. / IA control	Model no. / IC control	Model no. / IS control	SWL @ 500kPa (kg)	SWL @ 600kPa (kg)	SWL @ 700kPa (kg)	Lifting travel (m)	Body diameter (mm)	Weight (kg)
Single wire rope									
IBW015080 ⁽²⁾	IAW015080 ⁽²⁾	ICW015080 ⁽²⁾	ISW015080 ⁽²⁾	49	58	68	2.0	165	27
IBW020120	IAW020120	ICW020120	ISW020120	65	78	91	3.0	254	33
IBW033080	IAW033080	ICW033080	ISW033080	107	128	150	2.0	254	33
IBW050080	IAW050080	ICW050080	ISW050080	162	194	227	2.0	254	54
Reeved wire rope									
IBW040060	IAW040060	ICW040060	ISW040060	130	156	182	1524	254	30
IBW066040	IAW066040	ICW066040	ISW066040	114	256	300	1016	254	35
IBW100040	IAW100040	ICW100040	ISW100040	324	388	454	1016	254	57

(2) Not available with Z Stop option.

See model identification codes on following page.

IntelLIFT® Series Balancers

Model identification codes

Example: **IAW020120 A2 2 S 0**

Option code	Description
Suspension	
00	No suspension
S2	IR ZRS2 steel rail
S3	IR ZRS3 steel rail
HM	Hook mount
TR ⁽³⁾	T-Rail / I-Beam
AT	IR ZRAT alu. rail
A1	IR ZRA1 alu. rail
A2	IR ZRA2 alu. rail
K1	KBK1 (Demag)
K2	KBK2 (Demag)
Input voltage	
1	115V 50/60 Hz 1Ph
2	230V 50/60 Hz 1Ph.
Z-stop	
0	None
S	Z-stop
Power cord	
0	None (plug / no wire)

Dimensions

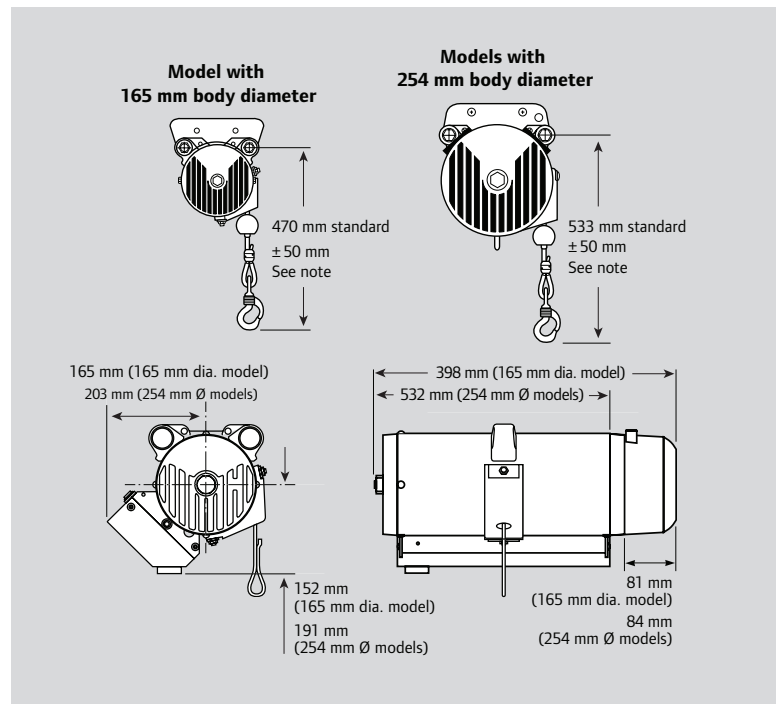

Note: add 25 mm in length for Z-Stop option. Add 152 mm for reeved units.

IntelLIFT® integrated solutions

A complete range of end effectors can be used with IntelLIFT controls for greater efficiency, from the simplest to the most complex device.

The IntelLIFT unit incorporates a fully grounded, fault-protected electrical system, with fused circuits and memory that automatically reinstates function selections following a power interruption. In every respect, the Ingersoll Rand IntelLIFT air balancer is an essential solution for a more productive workplace; empowering individuals to work comfortably and effectively, significantly contributing to product and process quality.

The closed-loop feedback system delivers precise, responsive motion control suitable for a wide range of applications in:



Vehicle assembly

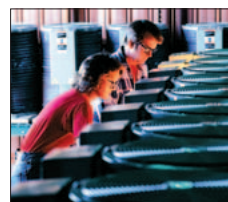

General industry



Beverage and warehouse



Biotechnology

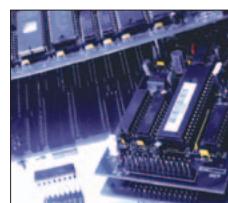

Electronics



Aerospace

IntelLIFT® integrated solutions

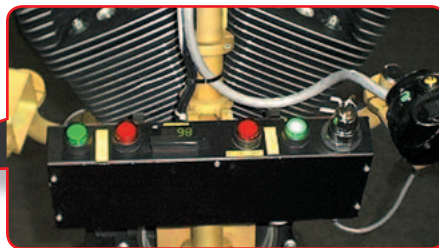
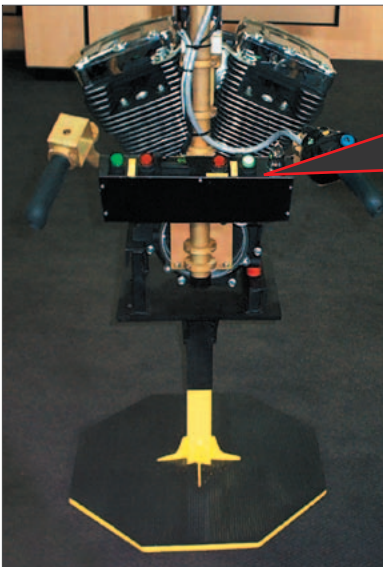

Error-proof assembly:

The device digitally displays the weight of the part picked up. Device will not allow the operator to move the part if not clamped properly. The key allows the operator the ability to lock the device. Allows 100 percent visual inspection of the assembly.

The engine-handling device shown uses the unique features of the IntelLIFT balancer. Features include: auto clamp, interlock, up control disable, weight sensing with automatic alarm, and keyed lockout.

The warehouse-handling device shown is known for its versatility. The device mimics the human motion of picking up a part and placing it down. The same device can be used to pick up parts such as totes, trays, boxes, and milk crates. The self-balance feature allows the same device to pick up parts of different weights and sizes.



B-Series Spring Balancers

Features

B-Series spring balancers compensate weight of your power tools or other manufacturing equipment and enable operator to lift or lower it with minimal effort. Series BIDS, BHD and BSD(L) feature "Zero Gravity" effect allowing virtually effortless load repositioning all along cable travel.

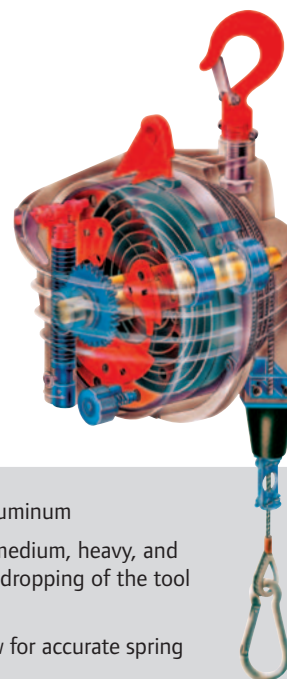

The Ingersoll Rand spring balancer **ADVANTAGE**

- ▶ **60 models** from which to choose
- ▶ **Five different series** to meet all balancing requirements
- ▶ Covers weight-balancing needs from **0.4 to 180 kg**
- ▶ Lifts ranging from **1.6 to 3 m**
- ▶ **"Gravity-free"** effect on intermediate, heavy, and super-duty models allows user to move tool with minimal effort
- ▶ Made of **rugged die-cast aluminum**
- ▶ **Safety locking device** on medium, heavy, and super-duty models prevents dropping of the tool should the spring fail
- ▶ **Easy-to-use controls** allow for accurate spring adjustment

Balancers product information

Standard equipment / Series	BLD Series	BMD Series	BIDS Series	BHD Series	BSD(L) Series
Stainless steel cable and anti-friction cable guide	•	•	•	•	•
Auxiliary safety suspension	•	•	•	•	•
Adjustable stroke limiting device	•	•	•	•	•
Inert spring drum assembly	•	•	•	•	•
Adjustable capacity (by means of a worm screw for BIDS, BHD & BSD Series)	•	•	•	•	•
Rotary load hook	–	–	Option: OPTRI		
Automatic safety brake acting in case of spring breakage	–	•	•	•	•
Top shackle for increased convenience (1)	•	•	–	–	–
Rotary upper suspension with safety hook on ball bearing	–	–	•	•	•
Locking device to block the load at any height	–	• / –	•	•	•
Tapered drum rotating on ball bearings for zero gravity effect	–	–	•	•	•
Optional floor control locking	–	–	–	BIL-7343	BIL-3224

1) For retrofit or replacement use BIL-23223 for BLD Series, and BIL-23224 for BMD Series (BMDS, BMDLN and BMDLLN).

Options

For rotating bottom hook, please order part no. OPTRI to install it on BIDS balancers. For BHD and BSD(L) Series, amend balancer part no. with "OPTRI"

Locking/unlocking device for control from the floor:
 Part no. BIL-7343 (for BHD Series).
 Part no. BIL-3224 (for BSD and BSD(L) Series)

Light duty balancers

Model no.	Load capacity (kg)	Max. stroke (m)	Weight (kg)
BLD-1	0.4 - 1.0	1.6	0.6
BLD-2	1.0 - 2.0	1.6	0.6
BLD-3	2.0 - 3.0	1.6	0.7

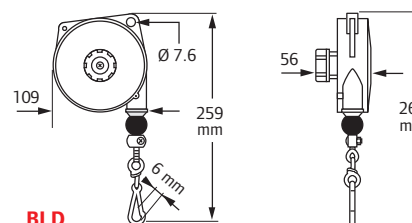
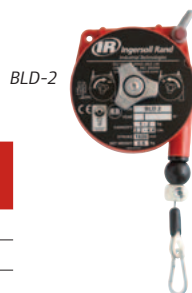

B-Series Spring Balancers



BSD-165



BHD-20



BIDS-14



BMDLN-4



BMDS-6

Medium and heavy duty balancers

Model no.	Load capacity (kg)	Max. stroke (m)	Weight (kg)
BMDS-2	1.0 - 2.5	2.0	2.0
BMDS-4	2.0 - 4.0	2.0	2.0
BMDS-6	4.0 - 6.0	2.0	2.3
BMDS-8	6.0 - 8.0	2.0	2.5
BMDLN-4	2.0 - 4.0	2.5	2.9
BMDLN-6	4.0 - 6.0	2.5	3.2
BMDLN-8	6.0 - 8.0	2.5	3.5
BMDLN-10	8.0 - 10	2.5	3.7
BMDLN-12	10.0 - 14	2.5	4.0
BMDLLN-4 ⁽¹⁾	2.0 - 4.0	2.5	3.0
BMDLLN-6 ⁽¹⁾	4.0 - 6.0	2.5	3.3
BMDLLN-8 ⁽¹⁾	6.0 - 8.0	2.5	3.6
BMDLLN-10 ⁽¹⁾	8.0 - 10	2.5	3.8
BIDS-7	4.0 - 7.0	2.0	5.0
BIDS-10	7.0 - 10	2.0	5.5
BIDS-14	10 - 14	2.0	5.5
BIDS-18	14 - 18	2.0	6.5
BIDS-22	18 - 22	2.0	6.0
BIDS-26	22 - 25	2.0	6.6
BHD-15	10 - 15	2.0	10.3
BHD-20	15 - 20	2.0	10.6
BHD-25	20 - 25	2.0	11.2
BHD-30	25 - 30	2.0	11.5
BHD-35	30 - 35	2.0	11.8
BHD-45	35 - 45	2.0	12.4
BHD-55	45 - 55	2.0	12.5
BHD-65	55 - 65	2.0	13.6

Super duty balancers

Model no.	Load capacity (kg)	Max. stroke (m)	Weight (kg)
BSD-20	15 - 20	2.5	19.0
BSD-30	20 - 30	2.5	19.8
BSD-40	30 - 40	2.5	20.8
BSD-50	40 - 50	2.5	23.9
BSD-60	50 - 60	2.5	25.4
BSD-70	60 - 70	2.5	26.8
BSD-80	70 - 80	2.5	27.8
BSD-90	80 - 90	2.5	28.8
BSD-100	90 - 100	2.5	35.6
BSD-120	100 - 120	2.5	38.8
BSD-140	120 - 140	2.5	41.8
BSD-150	130 - 150	2.5	44.5
BSD-165	150 - 165	2.5	48.2
BSDL-20	15 - 20	3.0	19.1
BSDL-25	20 - 25	3.0	19.9
BSDL-35	25 - 35	3.0	20.9
BSDL-45	35 - 45	3.0	23.8
BSDL-50	40 - 50	3.0	23.9
BSDL-60	50 - 60	3.0	25.3
BSDL-70	60 - 70	3.0	26.7
BSDL-80	70 - 80	3.0	28.0
BSDL-90	80 - 90	3.0	29.0
BSDL-100	90 - 100	3.0	36.8
BSDL-115	100 - 115	3.0	38.7
BSDL-130	115 - 130	3.0	39.9
BSDL-140	130 - 140	3.0	42.8
BSDL-150	140 - 150	3.0	45.6
BSDL-180	160 - 180	3.0	50.0

(1) Locking type balancer: sharp pull on the wire rope will lock it in position allowing attached load to be manipulated freely – without weight compensation. Pulling again will unlock the wire rope and resume weight compensation.

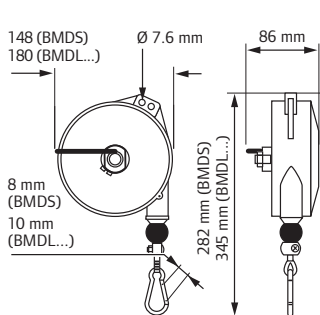

BMDS, BMDLN and BMDLLN

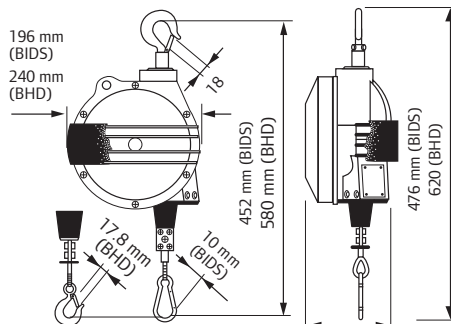

BIDS and BHD

140 mm (BIDS)
215 mm (BHD)

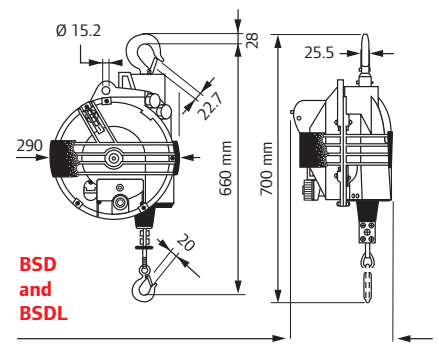

BSD and BSDL

221 mm (BSD-20 to BSD-60 and BSDL-20 to BSDL35)
270 mm (BSD-70 to BSD-100 and BSDL-45 to BSDL-100)
355 mm (BSD-120 to BSD-165 and BSDL-115 to BSDL-180)



Arm Systems

Great for reaching in, under and around obstacles to precisely and effortlessly position loads

Ingersoll Rand offers:

- ▶ Column or overhead mounting options
- ▶ Three styles: articulating, parallel link, and vertical mast
- ▶ Up to 3 m of horizontal reach
- ▶ Capacities up to 225 kg

The Ingersoll Rand arm system **ADVANTAGE**

- ▶ **Ergonomic reach:** prevents the need for operator to bend and reach into tight areas causing injury
- ▶ **Precise, strain-free positioning:** float leaves both hands free to raise, lower or shift the load with virtually no resistance
- ▶ **Versatility:** three styles available to fit a diverse set of applications in nearly any industry
- ▶ **Rugged reliability:** continuous duty with minimal maintenance
- ▶ **Integrated air supply:** prevents tangling of air lines running to below-the-hook handling devices

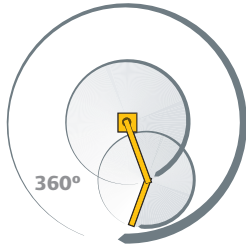

Parallel link arms

Parallel link arms utilize an air cylinder with a parallel link structure for lifting / lowering, making them ideal for reach-in applications.

Features:

- ▶ Capable of handling offset loads
- ▶ Column or carriage mount
- ▶ Optional brakes and limit switches available

Note: parallel link-style arms are designed to specific customer requirements. Contact factory for more information.

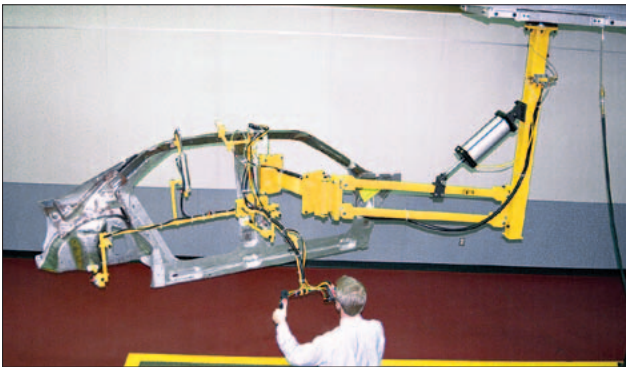

600 Series arms

600 Series arms utilize a rigid mast to guide the lifting / lowering, which is done by an integrated air balancer.

Features:

- ▶ Capable of handling offset loads
- ▶ Carriage mount compatible with most rail systems
- ▶ Up to 1.5 m vertical travel and 160 kg capacity
- ▶ Includes integrated air balancer



700 Series articulating arms →

700 Series arms combine the benefits of an air balancer with the flexibility and reach of an articulating arm.

Features:

- ▶ Column, ceiling, or carriage mount
- ▶ Up to 3 m horizontal reach and 225 kg capacity
- ▶ Includes integrated air balancer available in rear-mount, mid-mount and front-mount configurations.

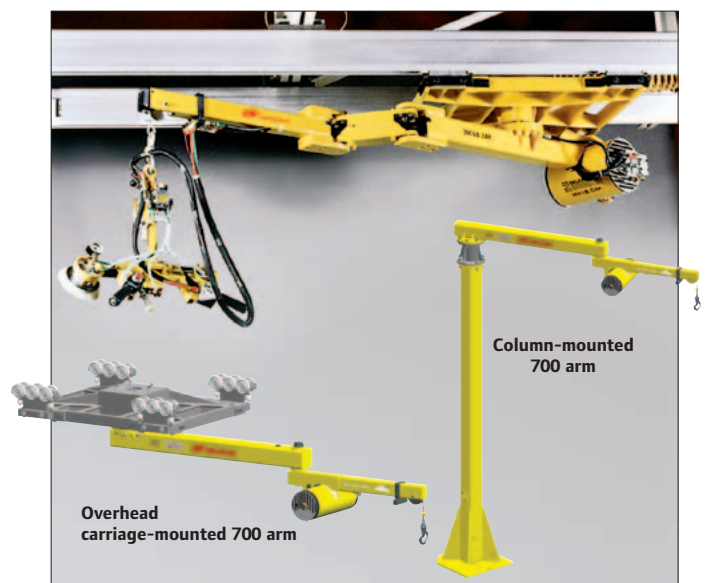

Arm Systems

600 Series arms

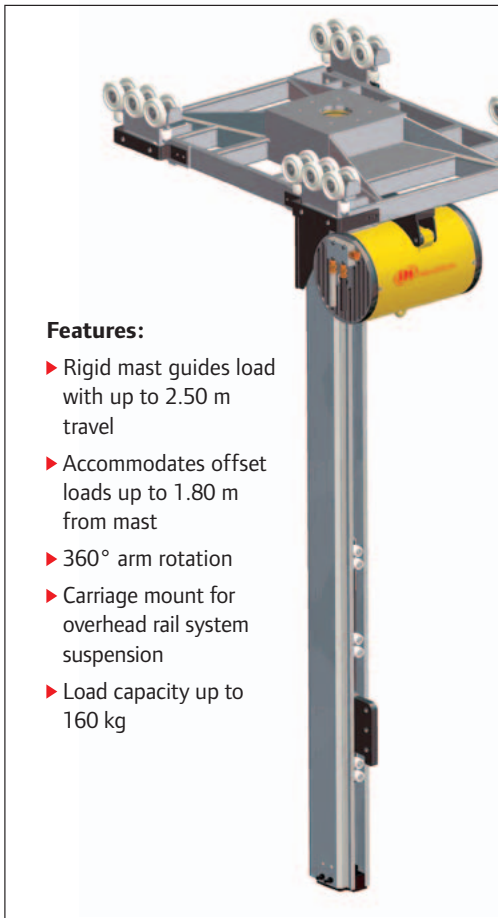

Features:

- ▶ Rigid mast guides load with up to 2.50 m travel
- ▶ Accommodates offset loads up to 1.80 m from mast
- ▶ 360° arm rotation
- ▶ Carriage mount for overhead rail system suspension
- ▶ Load capacity up to 160 kg

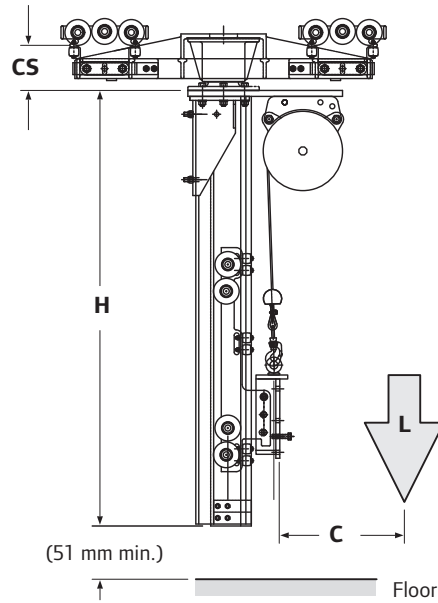

600 Series arm — Specifications

Load (L) max (kg)	Capacity (kg)	Load CG (C) max (mm)	Mast Ht. (H) max (mm)	Max hook travel (mm)
60020SA1A2ZXF	90	1829	2000	985
60020SA1A2ZXJ	90	1524	2500	1485
60035SA1A2ZXF	160	1219	2000	985
60035SA1A2ZXJ	160	914	2500	1485

Note: "X" in base model above requires brake option selection (see arm model driver for options configuration below).

600 Series arm model driver

Example: **60035SA1A2ZABJ**

Style	Capacity	Balancer	Mast	Carriage	Control	Brake options	Mast length
600 = 600 Series arm	20 = 90 kg 35 = 160 kg	SA = Standard balancer	1 = single mast	A2 = Carriage - ZRA2 (reaction trolley) <i>Note: All Ingersoll Rand 600 arms use a low profile carriage.</i>	Z = ZA up/down pendant control (includes dummy handle)	0 = No brake B = Bumper friction brake (soft stop at any point on 360° rotation)	F = 2.00 m J = 2.50 m

600 Series arm accessories

Description	Corresponding symbol in model driver	Part no.	Stack-up ⁽¹⁾ (CS) (mm)
Low profile carriage - ZRA2 (reaction trolley)	A2	30028-1	152
Up / down pendant control	ZA	54039847	—
Bumper friction brake	B	54039730	—

(1) Dimension is from the rail running surface to the base of the pivot. Changes with brake option
Note: lightweight ALMAG casting. Carriage weighs 27.3 kg.

700C Series arms

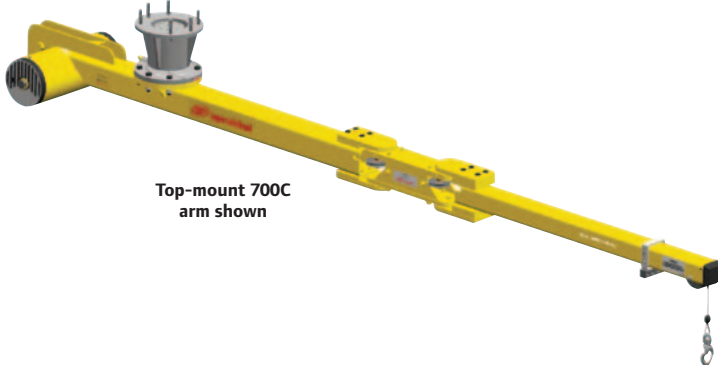

Top-mount 700C arm shown

Features:

- ▶ Rear-mount balancer offers lowest rotational inertia of all models
- ▶ Short stack-up for low headroom applications
- ▶ Two-point pivot providing 270° articulation
- ▶ Carriage or column mount
- ▶ Arm lengths of 1.8 m, 2.1 m, 2.4 m, 2.7 m and 3 m available
- ▶ Integrated 68, 90, 160, or 225 kg air balancer (@ 700 kpa, see page 21 for details)

700C Series arm — Specifications

Base model no.	Arm length (m)	Capacity (kg)	Weight (kg)
70015XXXXXXXX06X	1.83	68	99
70015XXXXXXXX07X	2.13	68	108
70015XXXXXXXX08X	2.44	68	113
70015XXXXXXXX09X	2.74	68	120
70015XXXXXXXX10X	3.05	68	125
70020XXXXXXXX06X	1.83	90	113
70020XXXXXXXX07X	2.13	90	121
70020XXXXXXXX08X	2.44	90	126
70020XXXXXXXX09X	2.74	90	126
70020XXXXXXXX10X	3.05	90	138
70035XXXXXXXX06X	1.83	160	117
70035XXXXXXXX07X	2.13	160	127
70035XXXXXXXX08X	2.44	160	132
70035XXXXXXXX09X	2.74	160	132
70035XXXXXXXX10X	3.05	160	144
70050XXXXXXXX06X	1.83	225	123
70050XXXXXXXX07X	2.13	225	132
70050XXXXXXXX08X	2.44	225	149
70050XXXXXXXX09X	2.74	225	159
70050XXXXXXXX10X	3.05	225	167

700C Series arm — Dimensions (mm)

							Top mount		Bottom mount	
A	B	C	D	G	J	K	H	L	H	L
1829	660	864	172	108	603	305	337	203	197	344
2134	965	864	172	108	603	305	337	203	197	344
2438	965	1168	172	108	603	305	337	203	197	344
2743	965	1168	172	108	603	610	337	203	197	344
3048	965	1168	172	108	603	915	337	203	197	344
1829	660	864	172	108	660	305	337	283	197	347
2134	965	864	172	108	660	305	337	283	197	347
2438	965	1168	172	108	660	305	337	283	197	347
2743	965	1168	172	108	660	610	337	283	197	347
3048	965	1168	172	108	660	915	337	283	197	347
1829	660	864	172	108	686	305	337	253	197	368
2134	965	864	172	108	686	305	337	253	197	368
2438	965	1168	172	108	686	305	337	253	197	368
2743	965	1168	172	108	686	610	337	253	197	368
3048	965	1168	172	108	686	915	337	253	197	368
1829	660	864	172	108	686	305	337	270	197	360
2134	965	864	172	108	686	305	337	270	197	360
2438	965	1168	216	140	686	305	337	289	197	422
2743	965	1168	216	140	686	610	337	289	197	422
3048	965	1168	216	140	686	915	337	289	197	422

(1) Note: "X" in base model above requires option selection (see arm model driver for options configuration on page 37)

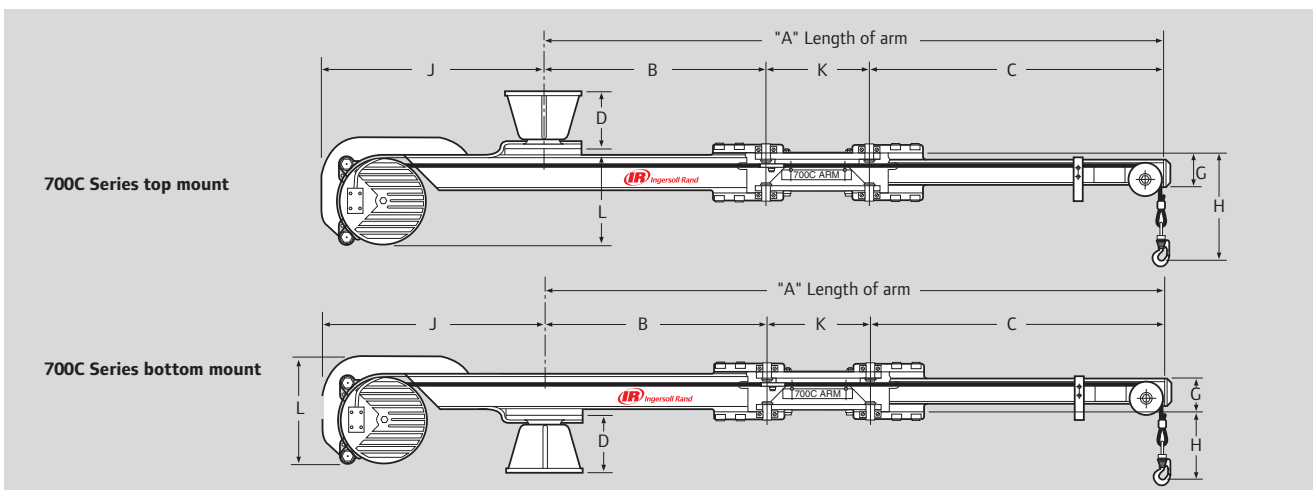

Arm Systems

713 Series arms



Top-mount 713 arm shown

Features:

- ▶ Mid-mount balancer
- ▶ Over-under boom design with single pivot point for 360° articulation
- ▶ Carriage or column mount
- ▶ Arm lengths of 1.8 m, 2.1 m, 2.4 m, 2.7 m and 3 m available
- ▶ Integrated 68, 90, 160, or 225 kg air balancer (@ 700 kpa, see page 21 for details)

713 Series arm — Specifications

Base model no.	Arm length (m)	Capacity (kg)	Weight (kg)
71315XXXXXXXX06X	1.83	68	69
71315XXXXXXXX07X	2.13	68	75
71315XXXXXXXX08X	2.44	68	80
71315XXXXXXXX09X	2.74	68	84
71315XXXXXXXX10X	3.05	68	104
71320XXXXXXXX06X	1.83	90	90
71320XXXXXXXX07X	2.13	90	97
71320XXXXXXXX08X	2.44	90	102
71320XXXXXXXX09X	2.74	90	107
71320XXXXXXXX10X	3.05	90	128
71335XXXXXXXX06X	1.83	160	106
71335XXXXXXXX07X	2.13	160	112
71335XXXXXXXX08X	2.44	160	119
71335XXXXXXXX09X	2.74	160	117
71335XXXXXXXX10X	3.05	160	123
71350XXXXXXXX06X	1.83	225	119
71350XXXXXXXX07X	2.13	225	125
71350XXXXXXXX08X	2.44	225	125
71350XXXXXXXX09X	2.74	225	152
71350XXXXXXXX10X	3.05	225	160

713 Series arm — Dimensions (mm)

								Top mount		Bottom mount	
A	B	C	D	F	G	H	E	K	E	K	
1829	1041	787	172	233	76	254	139	76	121	216	
2134	1194	940	172	233	76	254	139	76	121	216	
2438	1346	1092	172	233	76	254	139	76	121	216	
2743	1499	1245	172	233	76	254	139	76	121	216	
3048	1651	1397	172	233	76	254	139	76	121	216	
1829	1041	787	172	325	102	229	139	76	121	216	
2134	1194	940	172	325	102	229	139	76	121	216	
2438	1346	1092	172	325	102	229	139	76	121	216	
2743	1499	1245	172	325	102	229	139	76	121	216	
3048	1651	1397	172	325	102	229	139	76	121	216	
1829	1041	787	172	325	102	229	141	76	121	216	
2134	1194	940	172	325	102	229	141	76	121	216	
2438	1346	1092	172	325	102	229	141	76	121	216	
2743	1499	1245	172	325	102	229	172	76	152	216	
3048	1651	1397	172	325	102	229	172	76	152	216	
1829	1041	787	172	325	102	229	141	76	121	216	
2134	1194	940	172	325	102	229	141	76	121	216	
2438	1346	1092	216	325	102	229	172	76	152	216	
2743	1499	1245	216	325	102	229	172	76	152	216	
3048	1651	1397	216	325	102	229	172	76	152	216	

(1) Note: "X" in base model above requires option selection (see arm model driver for options configuration on page 37)

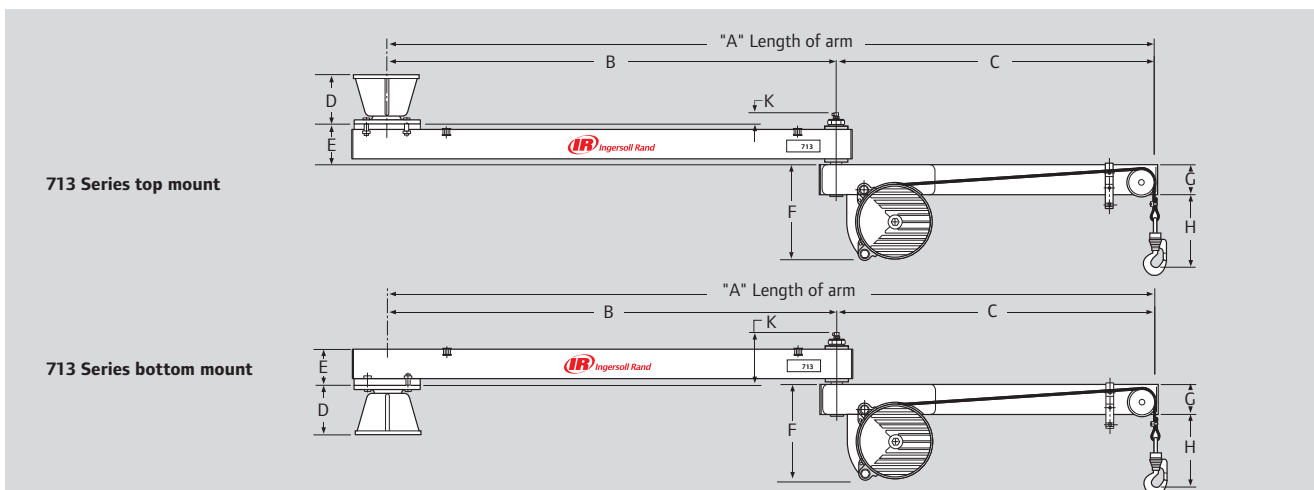

720 Series arms



Top-mount 720 arm shown

Features:

- ▶ End-mount balancer
- ▶ Over-under boom design with single pivot point for 360° articulation
- ▶ Carriage or column mount
- ▶ Arm lengths of 1.8 m, 2.1 m, 2.4 m, 2.7 m and 3 m available
- ▶ Available only in 68 kg capacity (@ 700 kpa, see page 21 for details)

720 Series arm — Specifications

Base model no.	Arm length (m)	Capacity (kg)	Weight (kg)
72015XXXXXXXX06X	1.83	68	99
72015XXXXXXXX07X	2.13	68	108
72015XXXXXXXX08X	2.44	68	113
72015XXXXXXXX09X	2.74	68	120
72015XXXXXXXX10X	3.05	68	125

720 Series arm — Dimensions (mm)

A	B	C	D	F	G	H	Top mount E	Bottom mount E
1829	1041	787	172	198	76	419	139	121
2134	1194	940	172	198	76	419	139	121
2438	1346	1092	172	198	76	419	139	121
2743	1499	1245	172	198	76	419	139	121
3048	1651	1397	172	198	76	419	139	121

(1) Note: "X" in base model above requires option selection (see arm model driver for options configuration on page 37)

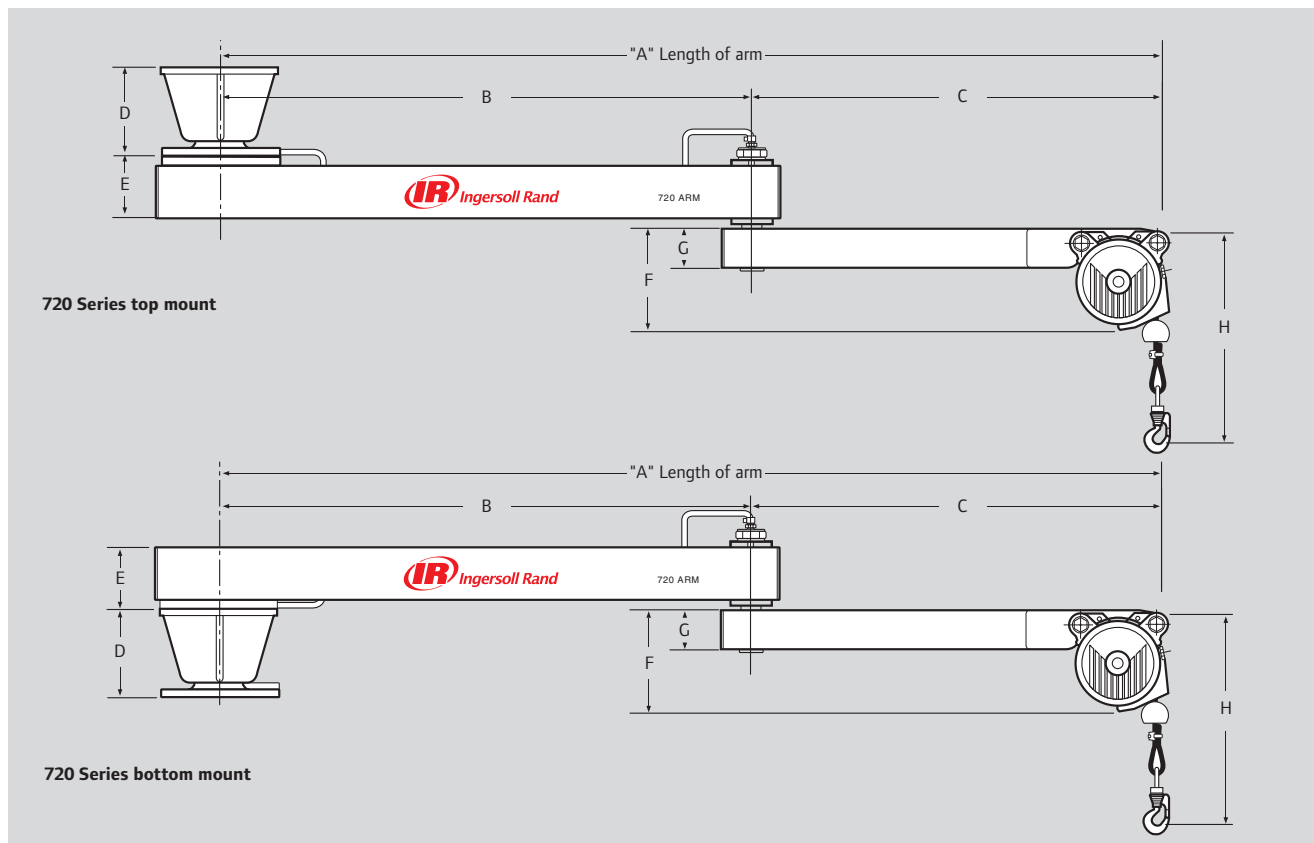

Arm Systems

700 Series arms options and accessories

Mounting accessories

Symbol	Description
A	Overhead mount column 333 mm tall (for use with ceiling-mounted arms)
B	Column, 2.44 m tall
C	Column, 2.60 m tall
D	Column, 2.75 m tall
E	Column, 3.05 m tall
F	Column, 3.35 m tall
G	Column, 3.65 m tall

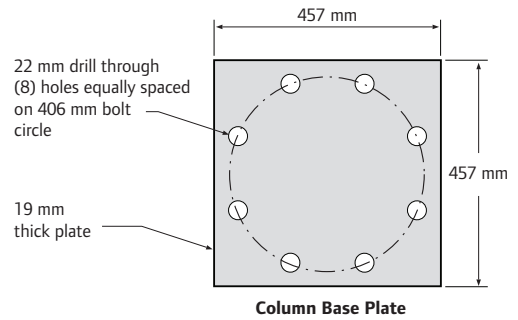

Carriages

Symbol	Description	Part no.
NT	Carriage – basic, no trolleys	40710
TR	Carriage assembly – T-rail / I-beam	40709
A2	Carriage assembly – ZRA2 (reaction trolley)	30028-1
S2	Carriage assembly – ZRS2 / ZRS3	30028-2
A1	Carriage assembly – ZRA1	30028-3
E8	Carriage assembly – ETA-8 (reaction trolley)	30028-4
K2	Carriage assembly – KBK2	30028-5

Note: lightweight ALMAG casting. Basic carriage weighs 27.3 kg.

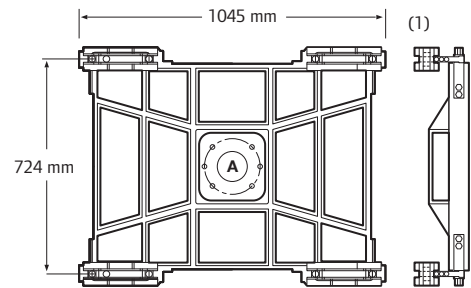

(1) **Note:** shown in low profile set-up.

A = 13 mm bolts (6), holes on a 190 mm bolt circle

Controls

Symbol	Description
ZP	ZA up / down pendant control
ZQ	ZA up / down pendant control with Quad-Coil
ZT	ZA up / down pendant control with Tri-Coil
BA	BA single balance control (only for use on 68 kg capacity units)
BZ	BA Z-servo, single balance control
EP	EA 2PS pressure, load / no-load balance control for use with clamp devices
EV	EA vacuum, load / no-load balance control for use with vacuum devices

700 Series articulating arm model driver

Example: **70015SATT0ZP06A**

Style	Capacity	Balancer type	Mounting option ⁽¹⁾	Carriage options	Control	Arm length	Mounting accessories
700 (68-225 kg capacity)	15 = 68 kg	SA = Standard balancer	TT = Top mount - ceiling	0 = No carriage	ZP = ZA pendant control	06 = 1.83 m	0 = No mounting column
713 (68-225 kg capacity)	20 = 90 kg	IA = Intelift balancer (consult factory)	BB = Bottom mount - column	H = High-profile	ZQ = ZA quad-coil control	07 = 2.13 m	A = 333 mm ceiling mount
720 (68 kg capacity only)	35 = 160 kg		NT = Carriage - no trolley	L = Low-profile	ZT = ZA tri-coil control	08 = 2.44 m	B = 2.44 m column
	50 = 225 kg		TR = Carriage - T-rail / I-beam		BA = Single balance control	09 = 2.74 m	C = 2.60 m column
			A2 = Carriage - ZRA2 (reaction trolley)		BZ = Z-servo balance control	10 = 3.05 m	D = 2.75 m column
			S2 = Carriage - ZRS2 / ZRS3		EP = EA control 2ps pressure		E = 3.05 m column
			A1 = Carriage - ZRA1		EV = EA control 2ps vacuum		F = 3.35 m column
			E8 = Carriage - ETA8 (reaction trolley)				G = 3.65 m column
			K2 = Carriage - KBK2				

(1) A1 carriage mount option is only available for arms with less than 90 kg capacity and less than 2.44 m arm length.



Handling Devices

Made for the interaction of man and machine

Ingersoll Rand offers:

- ▶ Standard and custom solutions
- ▶ Manual and powered tilt and rotation packages
- ▶ Innovative designs from the simplest to the most complex device

Handling Devices

The Ingersoll Rand handling device **ADVANTAGE**

- ▶ **Safety:** most Ingersoll Rand handling devices come equipped with a safety interlock system that will not allow the operator to accidentally disengage the part during transfer
- ▶ **Ergonomics:** handling devices can be designed with manual or powered tilt and rotation packages, which allow the operator to orient the part to the proper position with minimal effort
- ▶ **Flexibility:** through a variety of pneumatic packages, each system is matched to a control package that is tailored to the lifting and positioning task



Standard 4-cup vacuum handling device

- ▶ Safety Interlock prevents accidental release of load
- ▶ Improve productivity through effective box or flat part pickup, orientation, transfer, and positioning
- ▶ Adjustable handle and controls reduce operator fatigue
- ▶ Protects surface quality with positive secure vacuum gripping and setdown
- ▶ Gives operator complete control throughout the handling operation



Model no.	Cup centerline dimensions (mm)	Lift capacity		Cup diameter (mm)
		Vacuum (hPa)	@ 6.9 bar (100 psi)	
87306338	127 x 178	200 (porous)	20 kg	76
		610	44 kg	76
		850 (non-porous)	54 kg	76
87306486	254 x 356	200 (porous)	20 kg	76
		610	44 kg	76
		850 (non-porous)	54 kg	76

To be used with "BW" series pneumatic balancers. Alternate layout and vacuum cup sizes available on request
Note: vacuum cups require a flat, non-porous surface. Consult factory for applications with porous surfaces.

Vacuum handling device

Model no.	Description
ZV1S	1-Cup handling device
ZV1ST	1-Cup handling device with tilt
ZV4S	4-Cup handling device
ZC2S	Standard clamp device



Signature bundle handlers

- ▶ Designed to meet the needs of the printing industry in handling logs from 55 cm to 122 cm and up to 110 kg
- ▶ Single (250 mm stroke) and dual (760 stroke) air cylinders with 400 kg clamping force at 6.2 bar (90 psi)
- ▶ Safety interlock prevents accidental release of load
- ▶ Standard paddles for end boards up to 305 mm x 305 mm (extended paddle configurations available — contact factory)
- ▶ Power rotation and self-leveling packages available. Contact factory for further information
- ▶ Lightweight aluminum construction



Single cylinder with top swivel handle control



Dual cylinder with top swivel handle control

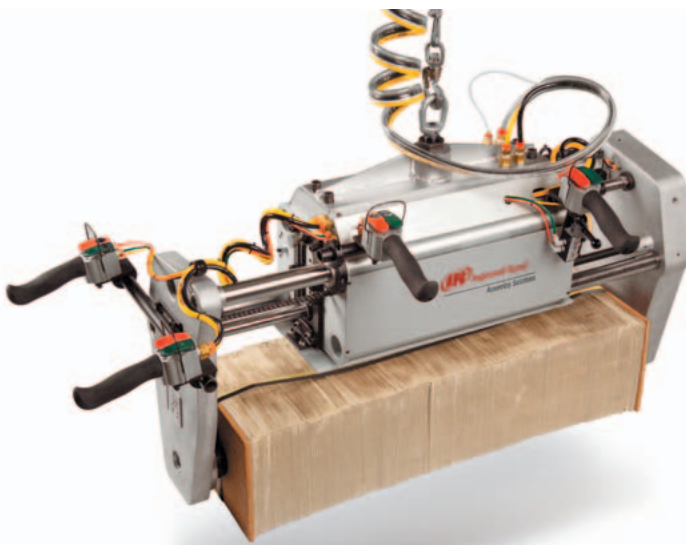

Dual cylinder with side control

Model no.	Body style	Control type	Bundle size (mm)	Stroke (mm)
SBH1-1-1	Single cylinder	Single side control	610-813	254
SBH1-2-1		Dual side control		
SBH1-3-1		End control		
SBH1-4-1		Side and end control		
SBH1-5-1		Top swivel handle control		
SBH1-1-2	Single cylinder	Single side control	813-1016	254
SBH1-2-2		Dual side control		
SBH1-3-2		End control		
SBH1-4-2		Side and end control		
SBH1-5-2		Top swivel handle control		
SBH1-1-3	Single cylinder	Single side control	1016-1219	254
SBH1-2-3		Dual side control		
SBH1-3-3		End control		
SBH1-4-3		Side and end control		
SBH1-5-3		Top swivel handle control		

Consult factory for applications that require greater than 254 mm stroke, dual cylinder available.

Handling Devices

Rotary action handlers

- ▶ Provides effortless 90 degree manual rotation of rolls up to 135 kg
- ▶ Non-destructive rubber band style as well as pin style noses engage the ID of the core
- ▶ Safety interlock prevents accidental release of load
- ▶ Offered in both lightweight aluminum and rugged steel construction
- ▶ Integrated up/down controls work seamlessly with Ingersoll Rand pneumatic balancer



Effortless horizontal to vertical rotation

Body selection chart

Body material	Capacity (kg)	Max. core length (mm)	Max. core O. D. (mm)
Aluminum	45.4	305	762
Steel	136.1	310	1067

Nose selection chart

Nose style	Capacity (kg)
3 Pin	45.4
6 Pin	163.1
Single band	90.7
Double band	136.1



Band nose



Pin nose



Custom power tilt

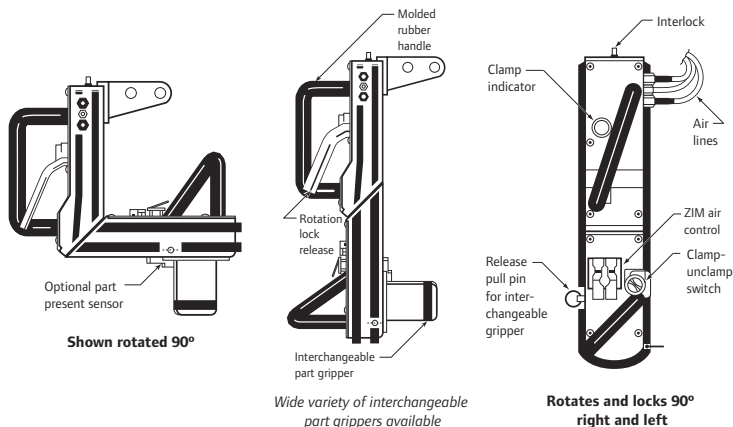

- ▶ Other options available upon request:
- ▶ Stepped nose for multiple cores
- ▶ "V" groove for pin cart applications
- ▶ Special paint / plating
- ▶ Spindle end locator
- ▶ Adjustable bail
- ▶ Heavy duty pivot for steel rotary action handler offers capacity up to 200 kg



Stepped nose

Rotary Action Handler model driver – Example: RAHA020030TP

Device type	Body material	Core I.D.		Core length		Nose style	Options			
RAH = Rotary action handler	A = Aluminum S = Steel	075 = 75 mm	020 = 2"	030 = 3" (76 mm)	070 = 7" (178 mm)	T = 3 Pin	P = Part present C = Side clamp (available only w/ steel body) I = Interchangeable nose w/ quick-release pins			
		094 = 94 mm	030 = 3"	035 = 3.5" (89 mm)	075 = 7.5" (190 mm)	S = 6 Pin				
		110 = 110 mm	040 = 4"	040 = 4" (102 mm)	080 = 8" (203 mm)	B = Single band				
		140 = 140 mm	050 = 5"	045 = 4.5" (114 mm)	XXX = Length (to be specified. 12" Max. for aluminum. 24" Max. for steel)	D = Double band				
		143 = 143 mm	060 = 6"	050 = 5" (127 mm)						
			080 = 8"	055 = 5.5" (140 mm)						
				060 = 6" (152 mm)						
				065 = 6.5" (165 mm)						
		To be used with "BW" series Pneumatic Balancers. Consult factory for applications with rolls prone to telescoping.								

Custom devices

Ingersoll Rand is a world leader in the manufacture of ergonomic, in-process, manual and powered custom material handling systems. We offer a complete range of handling devices, from the simplest to the most complex custom device. We specialize in providing turnkey solutions utilizing our complete line of standard and custom products to create a combination that empowers individuals to work more comfortably and effectively.



Motor vehicle



Agricultural equipment



Furniture / household

CLAMP



Cheese — food processing

HOOK / TRAP



Gaming table

VACUUM



Box — general industry

PROBE



Steel roll



Box — general industry



Beverage handling



Toilet tank



Ceramic steel funnel



Floor scrubber



Vehicle transmission



Glass



HVAC — copper coil

Contact factory for thousands more application photos and videos. E-mail requests to asbu_proposal@irco.com.

Torque Tube

The Ingersoll Rand torque tube **ADVANTAGE**

- ▶ **Guided lifting:** cylinder guides up/down motion, preventing load from swinging
- ▶ **Effortless vertical travel:** super linear bearings provide smooth, effortless motion
- ▶ **Versatility:** four models available for both torque reaction and lifting applications
- ▶ **Torque reaction:** 4 Delrin® wheels for torque reaction and side loading in all four directions
- ▶ **Adaptable:** universal mounting plate for bolt-on integration of tool holders and handling devices

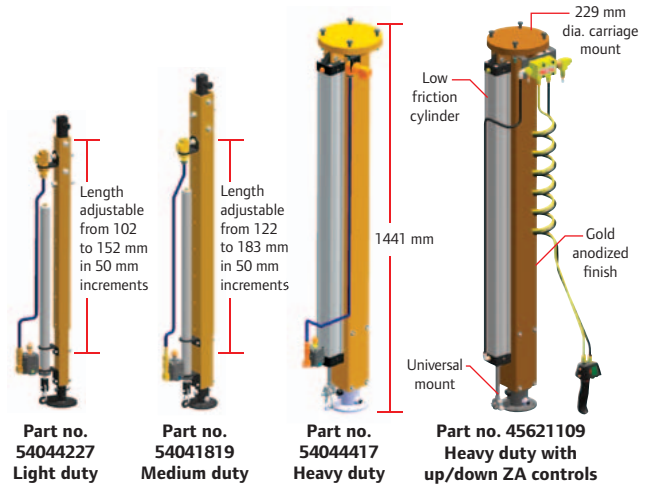

Torque tube with integrated vacuum handling device

Torque tube models

Model no.	Description	Torque capacity (Nm)	Lift capacity at 6.9 bar (kg)	Weight (kg)	Travel (mm)	Control
54044227	IRZ-TT-100	100	27	18	508	BA regulator
54041819	IRZ-TT-250	250	27	23	610	BA regulator
54044417 (1)	IRZ-TT-500	500	45	34	914	BA regulator
45621109 (1) (2)	IRZ-ZA-500	500	45	36	914	ZA up/down

(1) Carriage mount option only.

(2) Accommodates offset loads to 24" (609 mm). Consult factory for special applications.

Optional cylinder air supply

Part no. 90050. Cylinder air supply package. Includes regulator assembly and all required hose fittings to supply cylinder.

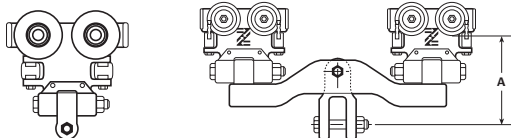

Suspension kit, single trolley

Suspension kit, dual trolley

Suspension kit options – single and dual trolleys

Model no	Rail profile	"A" Dimension (mm)	Weight (kg)
Single trolley – Used for 80 Nm or less applications			
16610	ZRA2	120	2.0
16600	ZRAS2/3	120	2.0
16615	KBK-II/IIL	120	2.0
16635	ETA-8	120	2.0
16620	T-Rail	76	6.8
Dual trolley – Up to 150 Nm applications			
16755	ZRAT	165	4.8
16705	ZRA1	156	4.8
16710	ZRA2	172	4.8
16700	ZRAS2/3	172	4.8
16725	KBK-I	156	4.8
16715	KBK-II/IIL	172	4.8
16744	ETA-4	156	4.8
16735	ETA-8	172	4.8

Note: for use on torque tube part no. 54044227 and 54041819.

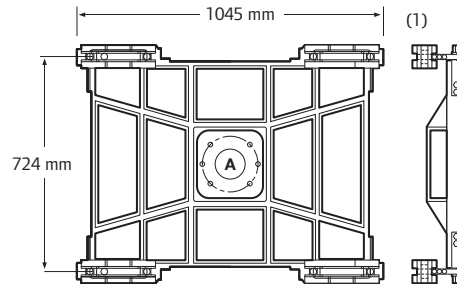

(1) Note: shown in low profile set-up.

A = 13 mm bolts (6), holes on a 190 mm bolt circle

Carriage options

Model no.	Description
40710	Carriage — basic, no trolleys
40709	Carriage assembly — T-rail / I-beam
30028-1	Carriage assembly — ZRA2 (reaction trolley)
30028-2	Carriage assembly — ZRS2 / ZRS3
30028-3	Carriage assembly — ZRA1
30028-4	Carriage assembly — ETA-8 (reaction trolley)
30028-5	Carriage assembly — KBK2

Note: for use on part no. 54044417 and 45621109

Lightweight ALMAG casting. Basic carriage weighs 27.3 kg

Each carriage drawing has info for both high and low profile assemblies

Other Products from Ingersoll Rand

Assembly Solutions

Ingersoll Rand offers a full line of production fastening equipment, including DC electric fastening systems and air assembly tools in a broad range of configurations. See our website ingersollrandproducts.com

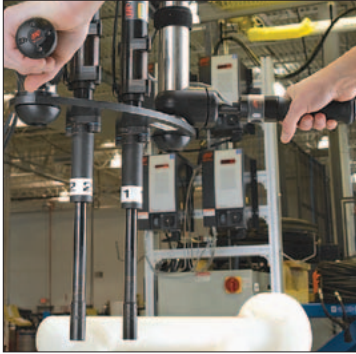

Industrial Lifting Equipment

Our range of industrial lifting equipment comprises air hoists and hoist-trolley combinations with load capacities from 250 kg to 50 ton — Control through pilot pendent for very precise positioning. See our website ingersollrandproducts.com





Ingersoll Rand (NYSE:IR) advances the quality of life by creating comfortable, sustainable and efficient environments. Our people and our family of brands—including Club Car®, Ingersoll Rand®, Thermo King® and Trane®—work together to enhance the quality and comfort of air in homes and buildings; transport and protect food and perishables; and increase industrial productivity and efficiency. We are a global business committed to a world of sustainable progress and enduring results.



ingersollrandproducts.com

We are committed to using environmentally conscious print practices.

Nothing contained on these pages is intended to extend any warranty or representation, expressed or implied, regarding the product described herein. Any such warranties or other terms and conditions of sale of product shall be in accordance with Ingersoll Rand's standard terms and conditions of sale for such products, which are available upon request. Product improvement is a continuing goal at Ingersoll Rand. Designs and specifications are subject to change without notice or obligation.